



Service Manual

Serial Number Range

AWP Super Series

from 3896-101
to 3801-99999
from AWP02-21194
to AWP16G-87799
from AWPG-87800

IWP Super Series

from 4096-101
to 4001-4413
from IWP02-4205
to IWP16G-11999
from IWPG-12000

Part No. 38139GT
Rev B12
September 2017

Introduction

Important

Read, understand and obey the safety rules and operating instructions in the appropriate Operator's Manual on your machine before attempting any maintenance procedure.

This manual provides detailed scheduled maintenance information for the machine owner and user. It also provides troubleshooting and repair procedures for qualified service professionals.

Basic mechanical, hydraulic and electrical skills are required to perform most procedures. However, several procedures require specialized skills, tools, lifting equipment and a suitable workshop. In these instances, we strongly recommend that maintenance and repair be performed at an authorized Genie dealer service center.

Compliance

Machine Classification

Group A/Type 1 as defined by ISO 16368

Machine Design Life

Unrestricted with proper operation, inspection and scheduled maintenance.

Technical Publications

Genie has endeavored to deliver the highest degree of accuracy possible. However, continuous improvement of our products is a Genie policy. Therefore, product specifications are subject to change without notice.

Readers are encouraged to notify Genie of errors and send in suggestions for improvement. All communications will be carefully considered for future printings of this and all other manuals.

Contact Us:

Internet: www.genielift.com
E-mail: awp.techpub@terex.com

Find a Manual for this Model

Go to <http://www.genielift.com>

Use the links to locate Service Manuals, Maintenance Manuals, Service and Repair Manuals, Parts Manuals and Operator's Manuals.

Copyright © 1996 by Terex Corporation

38139 Rev B, December 2001

First Edition, Second Printing

'Genie', 'AWP' and 'IWP' are registered trademarks of Terex South Dakota, in the U.S.A. and many other countries. "Super Series" is a trademark of Terex South Dakota.

Introduction

Revision History

Revision	Date	Section	Procedure / Page / Description
B8	5/2015	Maintenance	Removed C-6
B9	8/2016	Repair	5-4
B10	9/2016	Introduction	Serial Number Legend
B11	9/2016	Schematics	Page 166
B12	9/2017	Maintenance	B-9
Reference Examples:			<p style="text-align: center;">Electronic Version</p> <p>Click on any content or procedure in the Table of Contents to view the update.</p>
Section – Maintenance, B-3			
Section – Repair Procedure, 4-2			
Section – Fault Codes, All charts			
Section – Schematics, Legends and schematics			



Introduction

Revision History (continued)

Revision	Date	Section	Procedure / Page / Description
Reference Examples:			
Section – Maintenance, B-3			
Section – Repair Procedure, 4-2			Electronic Version Click on any content or procedure in the Table of Contents to view the update.
Section – Fault Codes, All charts			
Section – Schematics, Legends and schematics			



Introduction

Serial Number Legend

To August 31, 2016

Genie.
A TEREX BRAND

Model: Serial number: AWP16G-12345

Manufacture date: 01/02/2010 **Model year:** 2016

Elec/Hydr Schematic:

Power supply voltage/Pneumatic Pressure:

Nominal Power:

Machine unladen weight:

Max Load:
Occupants and Equipment must not exceed:

Maximum allowable inclination of the chassis:

Maximum Wind Speed:
Indoor:
Outdoor:

Gradeability:

Maximum allowable side force:

Maximum platform height:

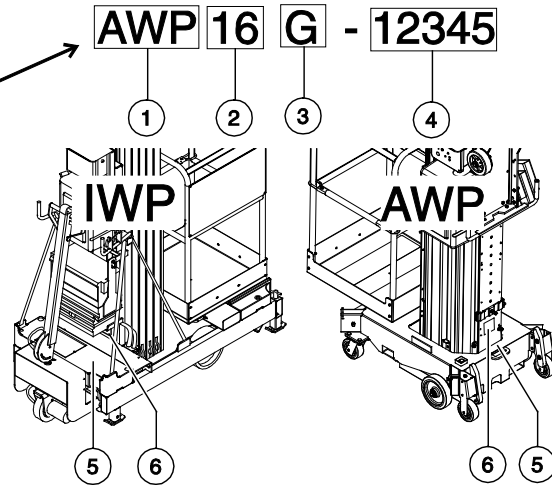

- 1 Model
- 2 Model year
- 3 Facility code

- 4 Sequence number
- 5 Serial number (stamped on chassis)
- 6 Serial label

From September 1, 2016

Genie.
A TEREX BRAND

Model: Serial number: AWPG-12345

Year of Manufacture : 2016

Elec/Hydr Schematic:

Power supply voltage/Pneumatic Pressure:

Nominal Power:

Machine unladen weight:

Max Load:
Occupants and Equipment must not exceed:

Maximum allowable inclination of the chassis:

Maximum Wind Speed:
Indoor:
Outdoor:

Gradeability:

Maximum allowable side force:

Maximum platform height:

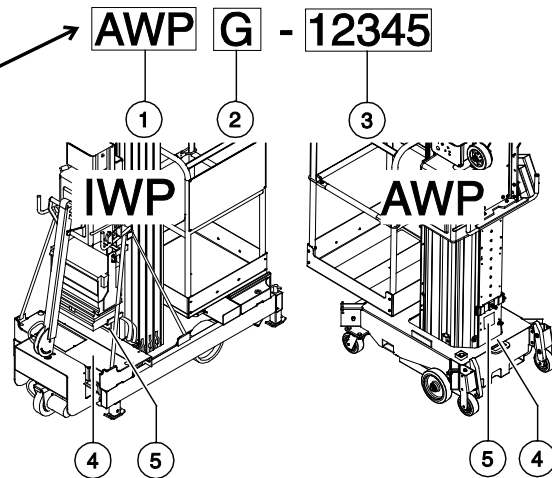

- 1 Model
- 2 Facility code
- 3 Sequence number

- 4 Serial number (stamped on chassis)
- 5 Serial label



Safety Rules



Danger

Failure to obey the instructions and safety rules in this manual and the appropriate Operator's Manual on your machine will result in death or serious injury.

Many of the hazards identified in the operator's manual are also safety hazards when maintenance and repair procedures are performed.

Do Not Perform Maintenance Unless:

- You are trained and qualified to perform maintenance on this machine.
- You read, understand and obey:
 - manufacturer's instructions and safety rules
 - employer's safety rules and worksite regulations
 - applicable governmental regulations
- You have the appropriate tools, lifting equipment and a suitable workshop.

Safety Rules

Personal Safety

Any person working on or around a machine must be aware of all known safety hazards. Personal safety and the continued safe operation of the machine should be your top priority.



Read each procedure thoroughly. This manual and the decals on the machine, use signal words to identify the following:



Safety alert symbol—used to alert personnel to potential personal injury hazards. Obey all safety messages that follow this symbol to avoid possible injury or death.



Indicates a imminently hazardous situation which, if not avoided, will result in death or serious injury.



Indicates a potentially hazardous situation which, if not avoided, could result in death or serious injury.



Indicates a potentially hazardous situation which, if not avoided, may cause minor or moderate injury.



Indicates a potentially hazardous situation which, if not avoided, may result in property damage.



Be sure to wear protective eye wear and other protective clothing if the situation warrants it.



Be aware of potential crushing hazards such as moving parts, free swinging or unsecured components when lifting or placing loads. Always wear approved steel-toed shoes.

Workplace Safety

Any person working on or around a machine must be aware of all known safety hazards. Personal safety and the continued safe operation of the machine should be your top priority.



Be sure to keep sparks, flames and lighted tobacco away from flammable and combustible materials like battery gases and engine fuels. Always have an approved fire extinguisher within easy reach.



Be sure that all tools and working areas are properly maintained and ready for use. Keep work surfaces clean and free of debris that could get into machine components and cause damage.



Be sure any forklift, overhead crane or other lifting or supporting device is fully capable of supporting and stabilizing the weight to be lifted. Use only chains or straps that are in good condition and of ample capacity.



Be sure that fasteners intended for one time use (i.e., cotter pins and self-locking nuts) are not reused. These components may fail if they are used a second time.



Be sure to properly dispose of old oil or other fluids. Use an approved container. Please be environmentally safe.



Be sure that your workshop or work area is properly ventilated and well lit.

Table of Contents

Introduction	Introduction ii
	Important Information ii
	Find a Manual for this Model..... ii
	Revision History iii
	Serial Number Legend v
<hr/>	
Section 1	Safety Rules vi
	General Safety Rulesvi
<hr/>	
Section 2	Specifications 17
	AWP-15S, 20S and 25S Specifications 17
	AWP30S, 36S and 40S Specifications 18
	AWP Narrow Base Specifications..... 19
	AWP Rough Terrain Base Specifications 20
	IWP Specifications 21
	AWP/IWP Performance and Hydraulic Specifications 22
	Hydraulic Hose and Fitting Torque Specifications 23
	Torque Procedure 24
	SAE and Metric Fasteners Torque Charts 26

Table of Contents

Section 3	Scheduled Maintenance Procedures	27
	Introduction	27
	Pre-Delivery Preparation Report	31
	Maintenance Inspection Report.....	33
	Checklist A Procedures	35
	A-1 Inspect the Manuals and Decals.....	35
	A-2 Perform Pre-operation Inspection.....	36
	A-3 Perform Function Tests	36
	A-4 Inspect for Damage and Loose or Missing Parts.....	37
	A-5 Check for Hydraulic Leaks.....	38
	A-6 Check the Hydraulic Oil Level.....	38
	A-7 Test the Base Operation - IWPS Models.....	39
	A-8 Test the Auxiliary Platform Lowering Operation	39
	A-9 Test the Manual Platform Lowering Operation	40
	A-10 Inspect the Columns for Damage	40
	A-11 Check the Sequencing Cables	41
	A-12 Check the Interlock System for Proper Operation	41
	A-13 Test the Power and Function Controls	43
	A-14 Inspect the Lifting Chains and Idler Wheels	43
	A-15 Inspect the Breather Cap.....	44
	A-16 Check the Tire Pressure - AWPS Models with Rough Terrain Base Option	45
	A-17 Check the Air Supply Lubricator Oil Level - Air Models.....	45
	A-18 Check the Air Supply Lubricator Drip Rate - Air Models	46
	A-19 Check the Air Filter/Regulator Canister - Air Models.....	46

Table of Contents

Checklist B Procedures	47
B-1 Inspect the Battery	47
B-2 Inspect the Electrical Wiring	47
B-3 Inspect All Welds	48
B-4 Test the Tilt-back Operation (if equipped).....	48
B-5 Check the Lifting Chain Adjustment	50
B-6 Clean and Lubricate the Columns	51
B-7 Test the Lifting Capacity.....	51
B-8 Adjust the Sequencing Cables	52
B-9 Inspect for Proper Outrigger Length - AWPS Models	53
B-10 Inspect and Lubricate the Outrigger Leveling Jack Footpads - AWPS Models	55
B-11 Test the Level Sensing Operation - IWPS Models.....	55
B-12 Check the Chain Adjustment, IWP-20S Models with Outreach Option.....	56
Checklist C Procedures	57
C-1 Inspect and Lubricate the Casters and Wheels	57
C-2 Inspect the Mast Assembly for Wear	57
C-3 Inspect and Lubricate the Lifting Chains.....	59
C-4 Replace the Hydraulic Oil.....	59
C-5 Replace the Auxiliary Platform Lowering Batteries	61

Table of Contents

Section 4	Repair Procedures	63
	Introduction	63
	Base Assembly	65
	1-1 Interlocks	65
	1-2 Base Components IWPS Models.....	66
	1-3 Foot Pump Manifold Components - IWPS Models (to SN IWP09-8269).....	70
	1-4 Foot Pump Manifold Components - IWPS Models (from SN IWP09-8270) ..	71
	1-5 Power Wheel Assist Manifold Components - IWPS Models (to SN 4097-990)	72
	1-6 Power Wheel Assist Manifold Components - IWPS Models (from SN 4097-997 to 4099-2532).....	73
	1-7 Power Wheel Assist Manifold Components - IWPS Models (from SN 4099-2533)	74
	Ground Controls.....	75
	2-1 How to Test the Transformer - AC Models	75
	2-2 How to Test the AC Contactor - AC Models	76
	Hydraulic Power Unit	77
	3-1 Hydraulic Power Unit - AC Models (to SN AWP03-27389 and IWP03-5150).....	77
	3-2 Hydraulic Power Unit - AC Models (from SN AWP03-27390 to AWP08-60145)	78
	3-3 Hydraulic Power Unit - DC Models (to SN AWP03-27401 and IWP03-5122).....	80
	3-4 Hydraulic Power Unit Components - Air Powered Models (to SN AWP04-27778)	82
	3-5 Hydraulic Power Unit.....	85
	3-6 Hydraulic Pump	87
	3-7 Valve Adjustment	87
	3-8 How to Test the Motor Start Solenoid - DC Models	88

Table of Contents

Power Pack	89
4-1 Power Pack.....	89
Mast Components	90
Mast Components.....	90
5-1 Lift Cylinder.....	91
5-2 Mast Assembly.....	92
5-3 Glide Pads.....	97
5-4 Lifting Chains.....	98
Tilt-back Frame, AWP-36S and 40S Models	101
6-1 Tilt-back Frame.....	101
Platform	103
7-1 Platforms.....	103
7-2 Platform Control Box.....	104
7-3 Platform Outreach Chain.....	105

Table of Contents

Section 5	Schematics.....	107
	Introduction.....	107
	Electrical Component and Wire Color Legends	108
	Electrical Symbol Legend.....	110
	Hydraulic Symbols Legend.....	111
	Electrical Schematics - AWP Models	113
	Electrical Schematic - AWP Super Series DC Models (from SN 3896-101 to 3896-300)	114
	Electrical Schematic - AWP Super Series DC Models (from SN 3896-301 to 3896-430)	115
	Electrical Schematic - AWP Super Series DC Models (from SN 3896-431 to AWP07-54898)	118
	Electrical Schematic - AWP Super Series DC Models with Standard Base (from SN AWP07-54899).....	119
	Electrical Schematic - AWP Super Series DC Models with Narrow Base (from SN AWP07-54899).....	122
	Electrical Schematic - AWP Super Series DC CE Models (from SN 3896-432 to AWP07-54898)	123
	Electrical Schematic - AWP Super Series DC CE Models with Standard Base (from SN AWP07-54899).....	126
	Electrical Schematic - AWP Super Series DC CE Models with Narrow Base (from SN AWP07-54899).....	127
	Electrical Schematic - AWP Super Series DC TUV Models (from SN 3896-431).....	130

Table of Contents

Electrical Schematic - AWP Super Series AC Models (from SN 3896-103 to 3896-303)	131
Electrical Schematic - AWP Super Series AC Models (from SN 3896-304 to 3896-450)	134
Electrical Schematic - AWP Super Series AC Models (from SN 3896-451 to AWP07-54898)	135
Electrical Schematic - AWP Super Series AC Models with Standard Base (from SN AWP07-54899 to AWP07-57594)	138
Electrical Schematic - AWP Super Series AC Models with Narrow Base (from SN AWP07-54899 to AWP-57594)	139
Electrical Schematic - AWP Super Series AC Models with Standard Base (from SN AWP07-57595)	142
Electrical Schematic - AWP Super Series AC Models with Narrow Base (from SN AWP07-57595)	143
Electrical Schematic - AWP Super Series AC CE Models (from SN 3896-451 to AWP07-54898)	146
Electrical Schematic - AWP Super Series AC CE Models with Standard Base (from SN AWP07-54899 to AWP07-57594)	147
Electrical Schematic - AWP Super Series AC CE Models with Narrow Base (from SN AWP07-54899 to AWP07-57594)	150
Electrical Schematic - AWP Super Series AC CE Models with Standard Base (from SN AWP-57595)	151
Electrical Schematic - AWP Super Series AC CE Models with Narrow Base (from SN AWP07-57595)	154
Electrical Schematic - AWP Super Series AC TUV Models (from SN 3896-461)	155

Table of Contents

Electrical Schematics - IWP Models	157
Electrical Schematic - IWP Super Series DC Models (from SN 4096-101 to 4096-287).....	158
Electrical Schematic - IWP Super Series DC Models (from SN 4096-288 to 4096-341).....	159
Electrical Schematic - IWP Super Series DC Models (from SN 4096-342 to IWP07-7065).....	162
Electrical Schematic - IWP Super Series DC Models (from SN IWP07-7066 to IWP15-9621).....	163
Electrical Schematic - IWP Super Series DC Models (from SN IWP15-9622) ..	166
Electrical Schematic - IWP Super Series DC Models with Power Assist.....	167
Electrical Schematic - IWP Super Series DC Models with Power Assist (Directional Valve Coils Powering Function Manifold).....	170
Electrical Schematic - IWP Super Series DC TUV Models	171
Electrical Schematic - IWP Super Series DC TUV Models with Outreach.....	174
Electrical Schematic - IWP Super Series DC TUV Models with Power Assist ..	175
Electrical Schematic - IWP Super Series DC TUV Models with Power Assist and Outreach	178
Electrical Schematic - IWP Super Series DC TUV Models with Power Assist (Directional Valve Coils Powering Function Manifold).....	179
Electrical Schematic - IWP Super Series AC Models (from SN 4096-105 to 4096-285).....	182
Electrical Schematic - IWP Super Series AC Models (from SN 4096-286 to 4096-355).....	183

Table of Contents

Electrical Schematic - IWP Super Series AC Models (from SN 4096-356 to IWP07-7065)	186
Electrical Schematic - IWP Super Series AC Models (from SN IWP07-7066 to IWP07-57594)	187
Electrical Schematic - IWP Super Series AC Models (from SN IWP07-57595)	190
Electrical Schematic - IWP Super Series AC TUV Models (With Base Mounted Junction Box).....	191
Electrical Schematic - IWP Super Series AC TUV Models (Without Base Mounted Junction Box).....	194
Electrical Schematic - IWP Super Series AC TUV Models with Outreach	195
Hydraulic Schematics - All Models	197
Hydraulic Schematic - AWP Super Series Models	198
Hydraulic/Pneumatic Schematic - AWP Super Series Models	199
Hydraulic Schematic - IWP Super Series Models without Power Assist	202
Hydraulic Schematic - IWP Super Series Models with Power Assist	203
Hydraulic Schematic - IWP Super Series Models with Power Assist and Brake	205

Specifications

Model	AWP-15S	AWP-20S	AWP-25S
Standard Base			
Height, working maximum	21 ft 4 in 6.5 m	26 ft 1 in 8.0 m	30 ft 9 in 9.4 m
Height, platform maximum	15 ft 4 in 4.7 m	20 ft 1 in 6.1 m	24 ft 9 in 7.6 m
Lift capacity all models except Canada	350 lbs 159 kg	350 lbs 159 kg	350 lbs 159 kg
Lift capacity models sold in Canada only	300 lbs 136 kg	300 lbs 136 kg	300 lbs 136 kg
Machine weight (DC / AC and Air models)	718 / 628 lbs 326 / 285 kg	764 / 674 lbs 347 / 306 kg	817 / 727 lbs 371 / 330 kg
Height, stowed	78 in 198 cm	78 in 198 cm	78 in 198 cm
Width	29 in 73.6 cm	29 in 73.6 cm	29 in 73.6 cm
Length	46 in 117 cm	46 in 117 cm	46 in 117 cm
Outrigger footprint (l x w) Domestic	60 3/4 x 52 3/4 in 154 x 134 cm	60 3/4 x 52 3/4 in 154 x 134 cm	60 3/4 x 52 3/4 in 154 x 134 cm
Outrigger footprint (l x w) CSA	60 3/4 x 52 3/4 in 154 x 134 cm	69 1/4 x 61 1/4 in 175.6 x 155.3 cm	83 1/2 x 75 1/2 in 212 x 191 cm
Outrigger footprint (l x w) CE Indoor	60 3/4 x 52 3/4 in 154 x 134 cm	60 3/4 x 52 3/4 in 154 x 134 cm	69 1/4 x 61 1/4 in 175.6 x 155.3 cm
Outrigger footprint* (l x w) CE Outdoor	69 1/4 x 61 1/4 in 175.6 x 155.3 cm	83 1/4 x 75 1/4 in 211.5 x 191.2 cm	89 x 81 in 225.9 x 205.6 cm
Corner access/wall access* Domestic	15 3/4 / 8 in 39.7 / 20.3 cm	14 1/2 / 5 1/2 in 36.9 / 7.4 cm	14 / 3 in 35.1 / 7.4 cm
Corner access/wall access* CSA	15 3/4 / 8 in 39.7 / 20.3 cm	20 1/4 / 9 3/4 in 51.2 / 24.5 cm	28 3/4 / 14 1/4 in 73 / 36.2 cm
Corner access/wall access* CE Indoor	15 3/4 / 8 in 39.7 / 20.3 cm	14 1/4 / 5 1/2 in 36.9 / 7.4 cm	19 1/4 / 7 1/4 in 48.6 / 18.2 cm
Corner access/wall access* CE Outdoor	21 1/2 / 12 1/4 in 54.6 / 30.8 cm	30 / 16 3/4 in 76 / 42.4 cm	32 1/2 / 17 in 82.5 / 43.4 cm

*Corner of platform top rail to corner of wall with ability to rotate the leveling jack.

Platform Dimensions - all models

Standard platform (L x W x H) gated or sliding mid-rail	27 x 26 x 44 3/4 in 69 x 66 x 114 cm	Gated narrow platform (L x W x H)	26 x 20 x 44 3/4 in 66 x 51 x 114 cm
Gated ultra-narrow platform (L x W x H)	22 x 18 x 44 3/4 in 56 x 46 x 114 cm	Standard fiber platform (L x W x H)	29 x 26 1/2 x 43 1/2 in 74 x 67 x 110 cm



Specifications

Model	AWP-30S	AWP-36S	AWP-40S
Standard Base			
Height, working maximum	35 ft 6 in 10.8 m	42 ft 5 in 12.9 m	46 ft 3 in 14.1 m
Height, platform maximum	29 ft 6 in 9.0 m	36 ft 6 in 6.1 m	40 ft 3 in 12.3 m
Lift capacity all models except Canada	350 lbs 159 kg	350 lbs 159 kg	300 lbs 136 kg
Lift capacity models sold in Canada only	300 lbs 136 kg	300 lbs 136 kg	300 lbs 136 kg
Machine weight (DC / AC and Air models)	831 / 741 lbs 377 / 336 kg	1107 / 1017 lbs 502 / 461 kg	1130 / 1040 lbs 513 / 472 kg
Height, stowed	78 in 198 cm	109 ½ in 278 cm	109 ½ in 278 cm
Width	29 in 73.6 cm	29 in 73.6 cm	29 in 73.6 cm
Length	46 in 117 cm	55 in 140 cm	55 in 140 cm
Outrigger footprint (l x w) Domestic	69 ¼ x 61 ¼ in 175.6 x 155.3 cm	83 ¼ x 75 ¼ in 211.5 x 191.2 cm	89 x 81 in 225.9 x 205.6 cm
Outrigger footprint (l x w) CSA	97 ½ x 89 ½ in 247.5 x 227.2 cm	117 ¼ x 109 ¼ in 297.8 x 278 cm	117 ¼ x 109 ¼ in 297.8 x 278 cm
Outrigger footprint (l x w) CE Indoor	75 ½ x 67 ½ in 192 x 171.4 cm	83 ¼ x 75 ¼ in 211.5 x 191.2 cm	89 x 81 in 225.9 x 205.6 cm
Outrigger footprint* (l x w) CE Outdoor	117 ¼ x 109 ½ in 297.8 x 278 cm	117 ¼ x 109 ¼ in 297.8 x 278 cm	117 ¼ x 109 ¼ in 297.8 x 278 cm
Corner access/wall access* Domestic	18 ½ / 4 ¾ in 46.6 / 11.9 cm	28 ½ / 14 ½ in 72.7 / 36.2 cm	31 ¼ / 14 ½ in 79.4 / 37.1 cm
Corner access/wall access* CSA	37 / 18 ¾ in 94.1 / 47.8 cm	52 / 31 ¼ in 132.5 / 79.3 cm	50 ¾ / 28 ¾ in 128.8 / 73 cm
Corner access/wall access* CE Indoor	22 ¼ / 8 in 56.6 / 20.3 cm	28 ½ / 14 ½ in 72.7 / 36.2 cm	31 ¼ / 14 ½ in 79.4 / 37.1 cm
Corner access/wall access* CE Outdoor	50 ¾ / 28 ¾ in 128.8 / 73 cm	52 / 31 ¼ in 132.5 / 79.3 cm	50 ¾ / 28 ¾ in 128.8 / 73 cm

*Corner of platform top rail to corner of wall with ability to rotate the leveling jack.

Platform Dimensions - all models

Narrow fiber platform (L x W x H)	26 x 22 x 43 ½ in 66 x 56 x 110 cm	Extra large platform (L x W x H)	30 x 28 x 44 ¾ in 76 x 71 x 114 cm
Front and side entry platform (L x W x H)	30 x 28 x 44 ¾ in 76 x 71 x 114 cm		



Specifications

Model	AWP-15S	AWP-20S	AWP-25S	AWP-30S
Narrow Base				
Machine weight (DC / AC and Air models)	711 / 621 lbs 322 / 282 kg	745 / 655 lbs 338 / 297 kg	780 / 690 lbs 353 / 313 kg	814 / 724 lbs 369 / 328 kg
Height, stowed	78 in 198 cm	78 in 198 cm	78 in 198 cm	78 in 198 cm
Width	22 in 55.8 cm	22 in 55.8 cm	22 in 55.8 cm	22 in 55.8 cm
Length	49 ½ in 125.7 cm	49 ½ in 125.7 cm	49 ½ in 125.7 cm	49 ½ in 125.7 cm
Outrigger footprint (l x w) Domestic	64 x 48 ¼ in 162.5 x 122.5 cm	64 x 48 ¼ in 162.5 x 122.5 cm	64 x 48 ¼ in 162.5 x 122.5 cm	71 ½ x 58 in 181.6 x 147.3 cm
Outrigger footprint (l x w) CSA	71 ½ x 58 in 181.6 x 147.3 cm	74 ½ x 65 ½ in 189.2 x 166.3 cm	83 ¼ x 74 in 211.4 x 187.9 cm	95 ¼ x 89 ¾ in 241.9 x 227.9 cm
Outrigger footprint (l x w) CE Indoor	64 x 48 ¼ in 162.5 x 122.5 cm	71 ¼ x 58 in 181.6 x 147.3 cm	71 ¼ x 58 in 181.6 x 147.3 cm	74 ½ x 65 ½ in 189.2 x 166.3 cm
Outrigger footprint* (l x w) CE Outdoor	83 ¼ x 74 in 211.4 x 187.9 cm	83 ¼ x 74 in 211.4 x 187.9 cm	95 ¼ x 89 ¾ in 241.9 x 227.9 cm	112 x 112 in 284.4 x 284.4 cm
Corner access/wall access* Domestic	16 / 11 in 40.6 / 27.9 cm	14 ¼ / 8 ½ in 36.2 / 21.6 cm	13 / 6 in 33 / 15.2 cm	18 ½ / 7 ¼ in 47 / 18.4 cm
Corner access/wall access* CSA	22 ½ / 14 ¾ in 57.1 / 37.5 cm	24 ½ / 14 in 62.2 / 35.5 cm	28 ¾ / 15 in 73 / 38.1 cm	37 ½ / 18 ½ in 95.2 / 47 cm
Corner access/wall access* CE Indoor	16 / 11 in 40.6 / 27.9 cm	21 / 12 ¼ in 53.3 / 31.1 cm	19 ½ / 9 ¾ in 49.5 / 24.7 cm	22 / 9 in 55.8 / 22.8 cm
Corner access/wall access* CE Outdoor	31 ½ / 20 ¼ in 80 / 50.8 cm	30 / 17 ½ in 76.2 / 44.4 cm	38 ¾ / 21 in 98.4 / 53.3 cm	51 / 26 ½ in 129.5 / 67.3 cm

*Corner of platform top rail to corner of wall with ability to rotate the leveling jack.

Platform Dimensions

Gated ultra-narrow platform (L x W x H)	22 x 18 x 44 ¾ in 56 x 46 x 114 cm	Narrow fiber platform (L x W x H)	26 x 22 x 43 ½ in 66 x 56 x 110 cm
Gated narrow platform (L x W x H)	26 x 20 x 44 ¾ in 66 x 51 x 114 cm		



Specifications

Model	AWP-15S	AWP-20S	AWP-25S	AWP-30S
Rough Terrain Base				
Machine weight (DC / AC and Air models)	715 / 625 lbs 324.5 / 283.7 kg	750 / 660 lbs 339.7 / 298.9 kg	784 / 694 lbs 355.3 / 314.6 kg	819 / 729 lbs 371 / 330.2 kg
Height, stowed	79 in 201 cm	79 in 201 cm	79 in 201 cm	79 in 201 cm
Width	29 ½ in 75 cm	29 ½ in 75 cm	29 ½ in 75 cm	29 ½ in 75 cm
Length	58 in 147 cm	58 in 147 cm	58 in 147 cm	58 in 147 cm
Outrigger footprint (l x w) Domestic	64 x 48 ¼ in 162.5 x 122.5 cm	64 x 48 ¼ in 162.5 x 122.5 cm	64 x 48 ¼ in 162.5 x 122.5 cm	71 ½ x 58 in 181.6 x 147.3 cm
Outrigger footprint (l x w) CSA	71 ½ x 58 in 181.6 x 147.3 cm	74 ½ x 65 ½ in 189.2 x 166.3 cm	83 ¼ x 74 in 211.4 x 187.9 cm	95 ¼ x 89 ¾ in 241.9 x 227.9 cm
Outrigger footprint (l x w) CE Indoor	64 x 48 ¼ in 162.5 x 122.5 cm	71 ¼ x 58 in 181.6 x 147.3 cm	71 ¼ x 58 in 181.6 x 147.3 cm	74 ½ x 65 ½ in 189.2 x 166.3 cm
Outrigger footprint* (l x w) CE Outdoor	83 ¼ x 74 in 211.4 x 187.9 cm	83 ¼ x 74 in 211.4 x 187.9 cm	95 ¼ x 89 ¾ in 241.9 x 227.9 cm	112 x 112 in 284.4 x 284.4 cm
Corner access/wall access* Domestic	16 / 11 in 40.6 / 27.9 cm	14 ¼ / 8 ½ in 36.2 / 7.4 cm	13 / 6 in 33 / 15.2 cm	18 ½ / 7 ¼ in 47 / 18.4 cm
Corner access/wall access* CSA	22 ½ / 14 ¾ in 57.1 / 37.5 cm	24 ½ / 14 in 62.2 / 35.5 cm	28 ¾ / 15 in 73 / 38.1 cm	37 ½ / 18 ½ in 95.2 / 47 cm
Corner access/wall access* CE Indoor	16 / 11 in 40.6 / 27.9 cm	21 / 12 ¼ in 53.3 / 31.1 cm	19 ½ / 9 ¾ in 49.5 / 24.7 cm	22 / 9 in 55.8 / 22.8 cm
Corner access/wall access* CE Outdoor	31 ½ / 20 ¼ in 80 / 50.8 cm	30 / 17 ½ in 76.2 / 44.4 cm	38 ¾ / 21 in 98.4 / 53.3 cm	51 / 26 ½ in 129.5 / 67.3 cm

*Corner of platform top rail to corner of wall with ability to rotate the leveling jack.

Platform Dimensions

Standard platform (L x W x H) gated or sliding mid-rail	27 x 26 x 44 ¾ in 69 x 66 x 114 cm	Narrow fiber platform (L x W x H)	26 x 22 x 43 ½ in 66 x 56 x 110 cm
Gated ultra-narrow platform (L x W x H)	22 x 18 x 44 ¾ in 56 x 46 x 114 cm	Front and side entry platform (L x W x H)	30 x 28 x 44 ¾ in 76 x 71 x 114 cm
Gated narrow platform (L x W x H)	26 x 20 x 44 ¾ in 66 x 51 x 114 cm	Extra large platform (L x W x H)	30 x 28 x 44 ¾ in 76 x 71 x 114 cm
Standard fiber platform (L x W x H)	29 x 26 ½ x 43 ½ in 74 x 67 x 110 cm		



Specifications

Model	IWP-20S	IWP-25S	IWP-30S
Height, working maximum	26 ft 5 in 8.1 m	30 ft 5 in 9.3 m	35 ft 6 in 10.8 m
Height, platform maximum	20 ft 5 in 6.2 m	24 ft 5 in 7.4 m	29 ft 6 in 9.0 m
Lift capacity	350 lbs 159 kg	350 lbs 159 kg	350 lbs 159 kg
Lift capacity with outreach option	300 lbs 136 kg	-- --	-- --
Machine weight (DC / AC models)	1245 / 1345 lbs 565 / 610 kg	1290 / 1390 lbs 585 / 630 kg	1290 / 1390 lbs 585 / 630 kg
Height, stowed base fully lowered/base raised	76 in / 78 in 198 cm / 203 cm	76 in / 78 in 198 cm / 203 cm	76 in / 78 in 198 cm / 203 cm
Width - Standard Base	32 in 81 cm	32 in 81 cm	-- --
Length - Standard base	60 in 152 cm	60 in 152 cm	-- --
Width - Wide Base	-- --	-- --	40 in 102 cm
Length - Wide Base	-- --	-- --	60 in 152.4 cm
Platform length	27 in 69 cm	27 in 69 cm	27 in 69 cm
Platform width	26 in 66 cm	26 in 66 cm	26 in 66 cm
Platform height	44 ¾ in 114 cm	44 ¾ in 114 cm	44 ¾ in 114 cm
Corner access	6 in 15 cm	6 in 15 cm	6 in 15 cm

Specifications

Platform function speed, maximum

AWP-15S, 20S, 25S and 30S

	AC	DC
Platform up	40 seconds	30 seconds
Platform down	28 seconds	28 seconds

AWP-36S

	AC	DC
Platform up	40 seconds	52 seconds
Platform down	42 seconds	42 seconds

AWP-40S

	AC	DC
Platform up	65 seconds	48 seconds
Platform down	38 seconds	38 seconds

IWP - All models

	AC	DC
Platform up	40 seconds	30 seconds
Platform down	28 seconds	28 seconds

Power Source AWP Models

DC models	12V
AC model	110V or 220V
Air model	100 psi / 6.9 bar

Power Source IWP Models

DC models	12V
AC model	110V or 220V

Ambient Operating Temperature

-20°F to 135°F
-29°C to 57°C

Hydraulic System

Hydraulic fluid	Chevron Rando HD equivalent
Hydraulic tank capacity - all models	3 quarts 2.8 liters

Hydraulic System Pressure

All models	1600 psi 110 bar
------------	---------------------

Hydraulic system capacity (includes tank)

IWP-20S	3.7 quarts	3.5 liters
IWP-25S	3.7 quarts	3.5 liters
IWP-30S	3.7 quarts	3.5 liters
AWP-15S	3.7 quarts	3.5 liters
AWP-20S	3.7 quarts	3.5 liters
AWP-25S	3.7 quarts	3.5 liters
AWP-30S	3.7 quarts	3.5 liters
AWP-36S	4.0 quarts	3.8 liters
AWP-40S	3.9 quarts	3.7 liters

Specifications

Hydraulic Hose and Fitting Torque Specifications

Your machine is equipped with Parker Seal-Lok™ ORFS or 37° JIC fittings and hose ends. Genie specifications require that fittings and hose ends be torqued to specification when they are removed and installed or when new hoses or fittings are installed.

Seal-Lok™ Fittings

(hose end - ORFS)

SAE Dash Size	Torque
-4	10 ft-lbs / 13.6 Nm
-6	30 ft-lbs / 40.7 Nm
-8	40 ft-lbs / 54.2 Nm
-10	60 ft-lbs / 81.3 Nm
-12	85 ft-lbs / 115 Nm
-16	110 ft-lbs / 150 Nm
-20	140 ft-lbs / 190 Nm
-24	180 ft-lbs / 245 Nm

JIC 37° Fittings

(swivel nut or hose connection)

SAE Dash Size	Thread Size	Flats
-4	7/16-20	2
-6	9/16-18	1 ¼
-8	3/4-16	1
-10	7/8-14	1
-12	1 1/16-12	1
-16	1 5/16-12	1
-20	1 5/8-12	1
-24	1 7/8-12	1

SAE O-ring Boss Port

(tube fitting - installed into Aluminum)
(all types)

SAE Dash Size	Torque
-4	14 ft-lbs / 19 Nm
-6	23 ft-lbs / 31.2 Nm
-8	36 ft-lbs / 54.2 Nm
-10	62 ft-lbs / 84 Nm
-12	84 ft-lbs / 114 Nm
-16	125 ft-lbs / 169.5 Nm
-20	151 ft-lbs / 204.7 Nm
-24	184 ft-lbs / 249.5 Nm

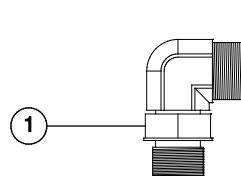

Adjustable Fitting



Non-adjustable fitting

1 jam nut

SAE O-ring Boss Port

(tube fitting - installed into Steel)

SAE Dash Size	Torque
-4 ORFS / 37° (Adj)	15 ft-lbs / 20.3 Nm
ORFS (Non-adj)	26 ft-lbs / 35.3 Nm
37° (Non-adj)	22 ft-lbs / 30 Nm
-6 ORFS (Adj / Non-adj)	35 ft-lbs / 47.5 Nm
37° (Adj / Non-adj)	29 ft-lbs / 39.3 Nm
-8 ORFS (Adj / Non-adj)	60 ft-lbs / 81.3 Nm
37° (Adj / Non-adj)	52 ft-lbs / 70.5 Nm
-10 ORFS (Adj / Non-adj)	100 ft-lbs / 135.6 Nm
37° (Adj / Non-adj)	85 ft-lbs / 115.3 Nm
-12 (All types)	135 ft-lbs / 183 Nm
-16 (All types)	200 ft-lbs / 271.2 Nm
-20 (All types)	250 ft-lbs / 339 Nm
-24 (All types)	305 ft-lbs / 413.5 Nm

Specifications

Torque Procedure

Seal-Lok™ fittings

- 1 Replace the O-ring. The O-ring must be replaced anytime the seal has been broken. The O-ring cannot be re-used if the fitting or hose end has been tightened beyond finger tight.

Note: The O-ring in Parker Seal Lok™ fittings and hose end are custom-size O-rings. They are not standard size O-rings. They are available in the O-ring field service kit (Genie part number 49612).

- 2 Lubricate the O-ring before installation.
- 3 Be sure the O-ring face seal is seated and retained properly.
- 4 Position the tube and nut squarely on the face seal end of the fitting, and tighten the nut finger tight.
- 5 Tighten the nut or fitting to the appropriate torque. Refer to the appropriate torque chart in this section.
- 6 Operate all machine functions and inspect the hose, fittings and related components to confirm there are no leaks.

JIC 37° fittings

- 1 Align the tube flare (hex nut) against the nose of the fitting body (body hex fitting) and tighten the hex nut to the body hex fitting to hand tight, approximately 30 in-lbs / 3.4 Nm.
- 2 Using a permanent ink marker, make a reference mark on one the flats of the hex nut and continue the mark onto the body of the hex fitting. Refer to Illustration 1.

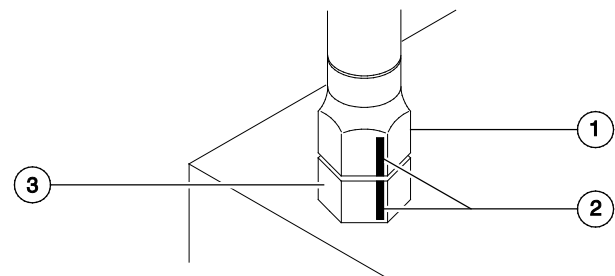

Illustration 1

- 1 hex nut
- 2 reference mark
- 3 body hex fitting

Specifications

- 3 Working clockwise on the body hex fitting, make a second mark with a permanent ink marker to indicate the proper tightening position. Refer to Illustration 2.

Note: Use the JIC 37° Fitting table in this section to determine the correct number of flats, for the proper tightening position.

Note: The marks indicate the correct tightening positions have been determined. Use the second mark on the body hex fitting to properly tighten the joint after it has been loosened.

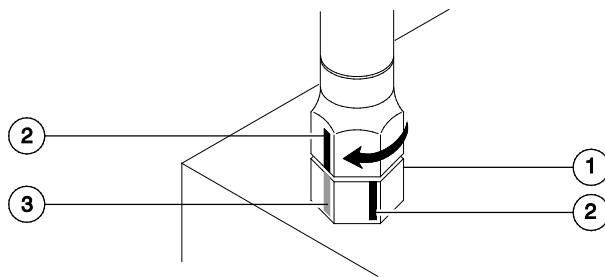







Illustration 2

- 1 body hex fitting
- 2 reference mark
- 3 second mark

- 4 Tighten the hex nut until the mark on the hex nut is aligned with the second mark on the body hex fitting.
- 5 Operate all machine functions and inspect the hose, fittings and related components to confirm there are no leaks.

Specifications

SAE FASTENER TORQUE CHART											
• This chart is to be used as a guide only unless noted elsewhere in this manual •											
SIZE	THREAD	Grade 5 				Grade 8 				A574 High Strength Black Oxide Bolts	
		LUBED		DRY		LUBED		DRY		LUBED	
		in-lbs	Nm	in-lbs	Nm	in-lbs	Nm	in-lbs	Nm	in-lbs	Nm
1/4	20	80	9	100	11.3	110	12.4	140	15.8	130	14.7
	28	90	10.1	120	13.5	120	13.5	160	18	140	15.8
		LUBED		DRY		LUBED		DRY		LUBED	
		ft-lbs	Nm	ft-lbs	Nm	ft-lbs	Nm	ft-lbs	Nm	ft-lbs	Nm
5/16	18	13	17.6	17	23	18	24	25	33.9	21	28.4
	24	14	19	19	25.7	20	27.1	27	36.6	24	32.5
3/8	16	23	31.2	31	42	33	44.7	44	59.6	38	51.5
	24	26	35.2	35	47.4	37	50.1	49	66.4	43	58.3
7/16	14	37	50.1	49	66.4	50	67.8	70	94.7	61	82.7
	20	41	55.5	55	74.5	60	81.3	80	108.4	68	92.1
1/2	13	57	77.3	75	101.6	80	108.4	110	149	93	126
	20	64	86.7	85	115	90	122	120	162	105	142
9/16	12	80	108.4	110	149	120	162	150	203	130	176
	18	90	122	120	162	130	176	170	230	140	189
5/8	11	110	149	150	203	160	217	210	284	180	244
	18	130	176	170	230	180	244	240	325	200	271
3/4	10	200	271	270	366	280	379	380	515	320	433
	16	220	298	300	406	310	420	420	569	350	474
7/8	9	320	433	430	583	450	610	610	827	510	691
	14	350	474	470	637	500	678	670	908	560	759
1	8	480	650	640	867	680	922	910	1233	770	1044
	12	530	718	710	962	750	1016	990	1342	840	1139
1 1/8	7	590	800	790	1071	970	1315	1290	1749	1090	1477
	12	670	908	890	1206	1080	1464	1440	1952	1220	1654
1 1/4	7	840	1138	1120	1518	1360	1844	1820	2467	1530	2074
	12	930	1260	1240	1681	1510	2047	2010	2725	1700	2304
1 1/2	6	1460	1979	1950	2643	2370	3213	3160	4284	2670	3620
	12	1640	2223	2190	2969	2670	3620	3560	4826	3000	4067

METRIC FASTENER TORQUE CHART																
• This chart is to be used as a guide only unless noted elsewhere in this manual •																
Size (mm)	Class 4.6 				Class 8.8 				Class 10.9 				Class 12.9 			
	LUBED		DRY		LUBED		DRY		LUBED		DRY		LUBED		DRY	
	in-lbs	Nm	in-lbs	Nm	in-lbs	Nm	in-lbs	Nm	in-lbs	Nm	in-lbs	Nm	in-lbs	Nm	in-lbs	Nm
5	16	1.8	21	2.4	41	4.63	54	6.18	58	6.63	78	8.84	68	7.75	91	10.3
6	19	3.05	36	4.07	69	7.87	93	10.5	100	11.3	132	15	116	13.2	155	17.6
7	45	5.12	60	6.83	116	13.2	155	17.6	167	18.9	223	25.2	1.95	22.1	260	29.4
	LUBED		DRY		LUBED		DRY		LUBED		DRY		LUBED		DRY	
	ft-lbs	Nm	ft-lbs	Nm	ft-lbs	Nm	ft-lbs	Nm	ft-lbs	Nm	ft-lbs	Nm	ft-lbs	Nm	ft-lbs	Nm
8	5.4	7.41	7.2	9.88	14	19.1	18.8	25.5	20.1	27.3	26.9	36.5	23.6	32	31.4	42.6
10	10.8	14.7	14.4	19.6	27.9	37.8	37.2	50.5	39.9	54.1	53.2	72.2	46.7	63.3	62.3	84.4
12	18.9	25.6	25.1	34.1	48.6	66	64.9	88	69.7	94.5	92.2	125	81	110	108	147
14	30.1	40.8	40	54.3	77.4	105	103	140	110	150	147	200	129	175	172	234
16	46.9	63.6	62.5	84.8	125	170	166	226	173	235	230	313	202	274	269	365
18	64.5	87.5	86.2	117	171	233	229	311	238	323	317	430	278	377	371	503
20	91	124	121	165	243	330	325	441	337	458	450	610	394	535	525	713
22	124	169	166	225	331	450	442	600	458	622	612	830	536	727	715	970
24	157	214	210	285	420	570	562	762	583	791	778	1055	682	925	909	1233



Scheduled Maintenance Procedures



Observe and Obey:

- ☑ Maintenance inspections shall be completed by a person trained and qualified on the maintenance of this machine.
- ☑ Scheduled maintenance inspections shall be completed daily, quarterly, and annually as specified on the *Maintenance inspection Report*. The frequency and extent of periodic examinations and tests may also depend on national regulations.

⚠ WARNING Failure to perform each procedure as presented and scheduled may cause death, serious injury or substantial damage.

- ☑ Immediately tag and remove from service a damaged or malfunctioning machine.
- ☑ Repair any machine damage or malfunction before operating the machine.
- ☑ Use only Genie approved replacement parts.
- ☑ Machines that have been out of service for a period longer than 3 months must complete the quarterly inspection.

Machine Configuration:

- ☑ Unless otherwise specified, perform each procedure with the machine in the following configuration:
 - Machine parked on a firm, level surface
 - Key switch in the off position with the key removed
 - The red Emergency Stop button in the off position at both the ground and platform controls
 - Wheels chocked
 - All external AC power supply disconnected from the machine
 - Platform in the stowed position

Scheduled Maintenance Procedures

About This Section

This section contains detailed procedures for each scheduled maintenance inspection.

Each procedure includes a description, safety warnings and step-by-step instructions.

Symbols Legend



Safety alert symbol—used to alert personnel to potential personal injury hazards. Obey all safety messages that follow this symbol to avoid possible injury or death.



Indicates a imminently hazardous situation which, if not avoided, will result in death or serious injury.



Indicates a potentially hazardous situation which, if not avoided, could result in death or serious injury.



Indicates a potentially hazardous situation which, if not avoided, may cause minor or moderate injury.



Indicates a potentially hazardous situation which, if not avoided, may result in property damage.

- ⊙ Indicates that a specific result is expected after performing a series of steps.
- ⊗ Indicates that an incorrect result has occurred after performing a series of steps.

Maintenance Symbols Legend

Note: The following symbols have been used in this manual to help communicate the intent of the instructions. When one or more of the symbols appear at the beginning of a maintenance procedure, it conveys the meaning below.



Indicates that tools will be required to perform this procedure.



Indicates that new parts will be required to perform this procedure.



Indicates that dealer service will be required to perform this procedure.



Indicates that a cold motor or pump will be required to perform this procedure.

Scheduled Maintenance Procedures

Pre-delivery Preparation Report

The pre-delivery preparation report contains checklists for each type of scheduled inspection.

Make copies for each inspection. Store completed forms as required.

Maintenance Schedule

The *Scheduled Maintenance Procedures* section and the *Maintenance Inspection Report* have been divided into subsections. Use the following chart to determine which group(s) of procedures are required to perform a scheduled inspection.

Inspection	Checklist
Daily or every 8 hours	A
Quarterly or every 250 hours	A + B
Annually or every 1000 hours	A + B + C

Maintenance Inspection Report

The maintenance inspection report contains checklists for each type of scheduled inspection.

Make copies of the *Maintenance Inspection Report* to use for each inspection. Maintain completed forms for a minimum of 4 years or in compliance with your employer, jobsite and governmental regulations and requirements.

This page intentionally left blank.

Pre-Delivery Preparation Report

Fundamentals

It is the responsibility of the owner or dealer to perform the Pre-delivery Preparation.

The Pre-delivery Preparation is performed prior to each delivery. The inspection is designed to discover if anything is apparently wrong with a machine before it is put into service.

A damaged or modified machine must never be used. If damage or any variation from factory delivered condition is discovered, the machine must be tagged and removed from service.

Repairs to the machine may only be made by a qualified service technician, according to the manufacturer's specifications.

Scheduled maintenance inspections shall be performed by qualified service technicians, according to the manufacturer's specifications and the requirements listed in the responsibilities manual.

Instructions

Use the operator's manual on your machine.

The Pre-delivery Preparation consists of completing the Pre-operation Inspection, the Maintenance items and the Function Tests.

Use this form to record the results. Place a check in the appropriate box after each part is completed. Follow the instructions in the operator's manual.

If any inspection receives an N, remove the machine from service, repair and re-inspect it. After repair, place a check in the R box.

Legend

- Y = yes, acceptable
- N = no, remove from service
- R = repaired

Comments

Pre-delivery Preparation	Y	N	R
Pre-operation inspection completed			
Maintenance items completed			
Function tests completed			

Model

Serial number

Date

Machine owner

Inspected by (print)

Inspector signature

Inspector title

Inspector company



Terex South Dakota, Inc USA
 500 Oak Wood Road
 PO Box 1150
 Watertown, SD 57201-6150
 (605) 882-4000

Genie UK
 The Maltings, Wharf Road
 Grantham, Lincolnshire
 NG31- 6BH England
 (44) 1476-584333

This page intentionally left blank.



Maintenance Inspection Report

Model

Serial number

Date

Hour meter

Machine owner

Inspected by (print)

Inspector signature

Inspector title

Inspector company

Instructions

- Make copies of this report to use for each inspection.
- Select the appropriate checklist(s) for the type of inspection(s) to perform.

<input type="checkbox"/>	Daily or every 8 hours	A
<input type="checkbox"/>	Quarterly or every 250 hours	A + B
<input type="checkbox"/>	Annually or every 1000 hours	A + B + C

- Place a check in the appropriate box after each inspection procedure is completed.
- Use the step-by-step procedures in this section to learn how to perform these inspections.
- If any inspection receives an "N," tag and remove the machine from service, repair and re-inspect it. After repair, place a check in the "R" box.

Legend

Y = yes, acceptable
 N = no, remove from service
 R = repaired

Checklist A		Y	N	R
A-1	Inspect the manuals and decals			
A-2	Pre-operation inspection			
A-3	Function tests			
A-4	Damage, loose or missing parts			
A-5	Hydraulic Leaks			
A-6	Check Hydraulic Oil Level			
A-7	Test base operation - IWP only			
A-8	Auxiliary lowering			
A-9	Manual lowering			
A-10	Columns			
A-11	Sequencing cables			
A-12	Interlock system			
A-13	Power and function controls			
A-14	Lifting chains and idler wheels			
A-15	Breather cap			

Checklist B		Y	N	R
B-1	Batteries			
B-2	Electrical wiring			
B-3	Welds			
B-4	Tilt-back operation			
B-5	Lifting chain adjustment			
B-6	Clean and lubricate columns			
B-7	Lifting capacity			
B-8	Sequencing cables			
B-9	Proper outrigger length			
B-10	Outrigger footpads			
B-11	Level sensing - IWP models			
B-12	Chain adjustment - IWP-20S with outreach			

Checklist C		Y	N	R
C-1	Caster and wheels			
C-2	Mast assembly			
C-3	Lifting chains			
C-4	Hydraulic oil			
C-5	Auxiliary platform lowering batteries			

Comments



This page intentionally left blank.



Checklist A Procedures

A-1 Inspect the Manuals and Decals

Genie specifications require that this procedure be performed every 8 hours or daily, whichever comes first.

Maintaining the operator's and safety manuals in good condition is essential to safe machine operation. Manuals are included with each machine and should be stored in the container provided in the platform. An illegible or missing manual will not provide safety and operational information necessary for a safe operating condition.

In addition, maintaining all of the safety and instructional decals in good condition is mandatory for safe machine operation. Decals alert operators and personnel to the many possible hazards associated with using this machine. They also provide users with operation and maintenance information. An illegible decal will fail to alert personnel of a procedure or hazard and could result in unsafe operating conditions.

- 1 Check to make sure that the operator's, safety and responsibilities manuals are present and complete in the storage container on the platform.
- 2 Examine the pages of each manual to be sure that they are legible and in good condition.
 - ⦿ Result: The operator's manual is appropriate for the machine and all manuals are legible and in good condition.
 - ⊗ Result: The operator's manual is not appropriate for the machine or all manuals are not in good condition or is illegible. Remove the machine from service until the manual is replaced.

- 3 Open the operator's manual to the decals inspection section. Carefully and thoroughly inspect all decals on the machine for legibility and damage.
 - ⦿ Result: The machine is equipped with all required decals, and all decals are legible and in good condition.
 - ⊗ Result: The machine is not equipped with all required decals, or one or more decals are illegible or in poor condition. Remove the machine from service until the decals are replaced.
- 4 Always return the manuals to the storage container after use.

Note: Contact your authorized Genie distributor or Genie if replacement manuals or decals are needed.

Checklist A Procedures

A-2 Perform Pre-operation Inspection

Genie specifications require that this procedure be performed every 8 hours or daily, whichever comes first.

Completing a Pre-operation Inspection is essential to safe machine operation. The Pre-operation Inspection is a visual inspection performed by the operator prior to each work shift. The inspection is designed to discover if anything is apparently wrong with a machine before the operator performs the function tests. The Pre-operation Inspection also serves to determine if routine maintenance procedures are required.

Complete information to perform this procedure is available in the appropriate operator's manual. Refer to the Operator's Manual on your machine.

A-3 Perform Function Tests

Genie specifications require that this procedure be performed every 8 hours or daily, whichever comes first.

Completing the function tests is essential to safe machine operation. Function tests are designed to discover any malfunctions before the machine is put into service. A malfunctioning machine must never be used. If malfunctions are discovered, the machine must be tagged and removed from service.

Complete information to perform this procedure is available in the appropriate operator's manual. Refer to the Operator's Manual on your machine.

Checklist A Procedures

A-4 Inspect for Damage and Loose or Missing Parts



Genie specifications require that this procedure be performed every 8 hours or daily, whichever comes first.

Daily machine condition inspections are essential to safe machine operation and good machine performance. Failure to locate and repair damage, and discover loose or missing parts may result in an unsafe operating condition.

- 1 Inspect the entire machine for damage and improperly installed or missing parts including:
 - Electrical components, wiring and electrical cables
 - Electrical cable anchors and pulleys
 - Hydraulic power unit, hoses, fittings, cylinder(s) and manifolds
 - Sequencing cables, anchors and pulleys
 - Lifting chains and idler wheels
 - Adjustable glide pads
 - Mast columns and counterweight(s)
 - Mast covers
 - Nuts, bolts and other fasteners
 - Platform entry mid-rail or gate
 - Breather cap
 - Dents or damage to machine
 - Corrosion or oxidation
 - Cracks in welds or structural components
 - IWPS models: Hydraulic manifolds and foot pump
 - IWPS models: Foot pads
 - AWPS models: Outriggers, leveling jacks and foot pads

IWPS models with Power Wheel Assist Option:

- Steer handle
- Hydraulic motor and hoses

IWP-20S models with Outreach Option:

- Locking bracket
- Handle and handle lock
- Outreach extension arms
- Chain and sprocket

Checklist A Procedures

A-5 Check for Hydraulic Leaks



Genie specifications require that this procedure be performed every 8 hours or daily, whichever comes first.

Detecting hydraulic fluid leaks is essential to operational safety and good machine performance. Undiscovered leaks can develop into hazardous conditions, impair machine functions and damage machine components.

- 1 Inspect for hydraulic oil puddles, dripping or residue on or around the following areas:
 - Hydraulic power unit—tank, valves, fittings
 - Flow control valve
 - Ground area under the machine
 - Hydraulic hoses and fittings
 - Hydraulic cylinder(s)

IWPS models: Hydraulic manifolds and foot pump

IWPS models with Power Wheel Assist Option:

- Hydraulic motor and hoses

A-6 Check the Hydraulic Oil Level



Genie specifications require that this procedure be performed every 8 hours or daily, whichever comes first.

Maintaining the hydraulic oil at the proper level is essential to machine operation. Improper hydraulic oil levels can damage hydraulic components. Daily checks allow the inspector to identify changes in oil level that might indicate the presence of hydraulic system problems.

- 1 Be sure the platform is fully lowered.
- 2 Remove the fasteners from the hydraulic power unit cover.
- 3 Remove the power unit cover.
- 4 Check the sight gauge on the side of the hydraulic tank.
 - ⦿ Result: The hydraulic oil level should be visible in the middle of the sight gauge.
- 5 Add oil if needed. Do not overfill.
- 6 Replace the cover.

Hydraulic System

Hydraulic fluid	Chevron Rando HD equivalent
Hydraulic tank capacity - all models	3 quarts 2.8 liters

Checklist A Procedures

A-7 Test the Base Operation - IWPS Models

Genie specifications require that this procedure be performed every 8 hours or daily, whichever comes first.

Testing the base for proper operation is essential for safe machine operation. An unsafe working condition exists if the base fails to operate properly. The base should operate smoothly and be free of hesitation, jerking and binding.

- 1 Pump the foot pedal 7 to 9 complete strokes.
 - ⊙ Result: The non-adjustable foot pads should raise 1 ½ to 2 inches / 4 to 5 cm off the ground.
- 2 Pull the base lowering handle.
 - ⊙ Result: The base should lower, putting all four foot pads in firm contact with the ground.
- 3 Raise the platform slightly.
 - ⊙ Result: The inner frame wheels should lift off the ground.

A-8 Test the Auxiliary Platform Lowering Operation

Genie specifications require that this procedure be performed every 8 hours or daily, whichever comes first.

The auxiliary platform lowering is powered by a secondary battery pack that is located in the ground control box. The auxiliary platform lowering can be activated from the ground or platform controls. Detection of an auxiliary lowering malfunction is essential for safe machine operation. An unsafe working condition exists if the auxiliary platform lowering function does not operate in the event of a main power failure.

- 1 Raise the platform slightly.
- 2 Disconnect the power source from the machine.
- 3 Push in the auxiliary platform lowering button at the ground controls.
 - ⊙ Result: Platform should lower.
- 4 Connect the power source to the machine.
- 5 Raise the platform slightly.
- 6 Disconnect the power source from the machine.
- 7 Push in the control activate button and rotate the up/down switch in the down direction.
 - ⊙ Result: Platform should lower.

Checklist A Procedures

A-9 Test the Manual Platform Lowering Operation

Genie specifications require that this procedure be performed every 8 hours or daily, whichever comes first.

Detection of a manual lowering malfunction is essential for safe machine operation. An unsafe working condition exists if the manual lowering function does not operate in the event of a main and auxiliary power failure.

- 1 Raise the platform slightly.
 - 2 Activate the manual lowering valve located at the bottom of the hydraulic cylinder.
- ⊙ Result: Platform should lower.

A-10 Inspect the Columns for Damage

Genie specifications require that this procedure be performed every 8 hours or daily, whichever comes first.

Detection of damage to columns is essential for safe machine operation. An unsafe working condition exists if the columns are damaged and do not operate smoothly, free of hesitation and binding. A daily check of the columns allows the inspector to identify changes in the operating condition of the column assembly that might indicate damage.

- 1 Visually inspect each column for the following:
 - Dents, gouges or abrasions
 - Bends or warping
 - Excessive wear
 - 2 Raise and lower the platform through a complete cycle.
- ⊙ Result: The platform should raise and lower smoothly, free of hesitation and binding.

Checklist A Procedures

A-11 Check the Sequencing Cables

Genie specifications require that this procedure be performed every 8 hours or daily, whichever comes first.

Detection of damage to sequencing cables or components is essential for safe machine operation. An unsafe working condition exists if the sequencing components are damaged and do not operate smoothly. A daily check of the sequencing system allows the inspector to identify changes in the operating condition that might indicate damage.

- 1 Visually inspect the cables and components for the following:
 - Frayed or broken wire strands
 - Kinks in the cable
 - Corrosion
 - Paint or foreign materials
 - Broken or damaged pulleys
 - Unusual or excessive pulley wear
 - Split or cracked threaded swage ends
- 2 Confirm the following:
 - Cables are on the pulleys
 - Upper and lower cable ends are properly secured
 - Upper and lower mounting brackets are properly secured

A-12 Check the Interlock System for Proper Operation

Genie specifications require that this procedure be performed every 8 hours or daily, whichever comes first.

Testing the interlock system for malfunctions is essential for safe machine operation. An unsafe working condition exists if any interlock display light fails to operate properly.

AWPS models

- 1 Turn the key switch to ground control and pull out the red Emergency Stop button to the ON position. Twist to release the red Emergency Stop button at the platform controls.
 - ⊙ Result: AC & DC models: .The power should be on.
Air models: The air pressure gauge should read 80 - 110 psi / 5.5 - 7.8 bar
- 2 Slide each outrigger into a base socket until the outrigger lock pin snaps into place. Adjust outriggers to level using the outrigger screw jack until the base casters are slightly off the ground.

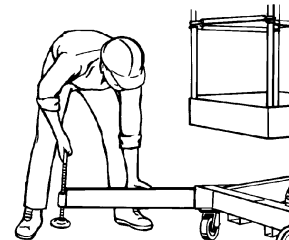

Checklist A Procedures

- 3 Check the interlock display lights at the ground controls.

- ⦿ Result: Confirm that the corresponding light is on.

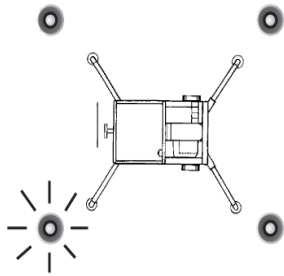

- 4 Repeat steps 2 and 3 for each of the remaining outriggers.

IWPS models

- 1 Turn the key switch to ground control and pull out the red Emergency Stop button to the ON position. Twist to release the red Emergency Stop button at the platform controls.

- ⦿ Result: The power light should be on.

- 2 Pull the base lowering handle to fully lower the base.

- 3 Use the bubble level and adjust the leveling jacks until the machine is level and all four foot pads are in firm contact with the ground.

- ⦿ Result: Within 1 to 3 seconds, all four interlock display lights should turn on and remain on.

- 4 Pump the foot pedal to raise the base.

- ⦿ Result: Both foot pad interlock display lights should be off.

- 5 Pull the base lowering handle to fully lower the base.

- ⦿ Result: The base will lower and both foot pad interlock display lights should be on.

- 6 Pump the foot pedal to raise the base.

- 7 Turn both leveling jacks clockwise to the full/extended position.

- 8 Pull the base lowering handle to fully lower the base.

- ⦿ Result: The base will lower and the two level sensor interlock display lights should be off and remain off.

- 9 Push in the red Emergency Stop button at the platform controls.

- 10 Push in the control activate button and rotate the up/down switch in the up position, then the down position.

- ⦿ Result: Platform up/down functions should not operate.

Checklist A Procedures

A-13 Test the Power and Function Controls

Genie specifications require that this procedure be performed every 8 hours or daily, whichever comes first.

Testing the machine functions and the Emergency Stop buttons for malfunctions is essential for safe machine operation. An unsafe working condition exists if any function fails to operate properly or either red Emergency Stop button fails to stop all the machine functions. Each function should operate smoothly and be free of hesitation, jerking and unusual noise.

- 1 Turn the key switch to ground control and pull out the red Emergency Stop button to the ON position. Twist to release the red Emergency Stop button at the platform controls.
 - ⊙ Result: The power light should be on.
- 2 Push in the control activate button and rotate the up/down switch in the UP position, then the DOWN position.
 - ⊙ Result: Platform up/down functions should operate.
- 3 Push in the red Emergency Stop button at the platform controls to the OFF position.
- 4 Push in the control activate button and rotate the up/down switch in the UP position, then the DOWN position.
 - ⊙ Result: The up/down functions should not operate.
- 5 Push in the red Emergency Stop button at both platform and ground controls.
- 6 Push in the control activate button and rotate the up/down switch in the UP position, then the DOWN position.
 - ⊙ Result: The up/down functions should not operate.

A-14 Inspect the Lifting Chains and Idler Wheels

Genie specifications require that this procedure be performed every 8 hours or daily, whichever comes first.

Maintaining the lifting chains and idler wheels in good condition is essential to safe machine operation. Failure to find and replace damaged chains or idler wheels could result in unsafe operating conditions and may cause component damage

- 1 Raise the platform approximately 3 feet / 1 m.
- 2 Visually inspect the chains and idler wheels near the top of each column for the following:
 - Excessive corrosion
 - Broken or missing chain leafs and pins
 - Tight or kinked joints in the chain
 - Missing or damaged idler wheels and related components
- 3 Inspect the chain terminations near the bottom of each column to confirm that each termination has a lock nut.

Checklist A Procedures

- 4 Inspect the chain terminations near the bottom of each column to confirm that the chain tensioner bracket is centered in the inspection hole.

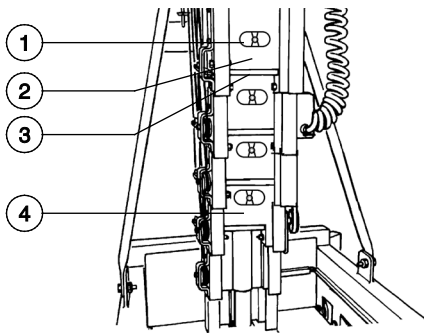

- 1 chain tensioner bracket
- 2 adjustment nut (hidden from view)
- 3 termination rod (hidden from view)
- 4 column

A-15 Inspect the Breather Cap

Genie specifications require that this procedure be performed every 8 hours or daily, whichever comes first.

The hydraulic tank is vented to the atmosphere. The breather cap has an internal air filter that can clog and may cause the power unit to operate improperly. If the breather cap is not properly installed and checked daily, impurities can enter the hydraulic system and may cause component damage.

- 1 Be sure the breather cap is installed on the hydraulic power unit tank and is not damaged. Do not remove it.

Checklist A Procedures

A-16

Check the Tire Pressure - AWPS Models with Rough Terrain Base Option



Genie specifications require that this procedure be performed every 8 hours or daily, whichever comes first.

It is essential to maintain proper pressure in all air-filled tires. Improperly inflated tires can affect machine handling.

- 1 Check each tire with an air pressure gauge. Add air as needed.

Models before serial number 3899-11837.

- ⦿ Tire pressure should be 30 psi / 2 bar in the front and rear tires.

Models after serial number 3899-11836.

- ⦿ Tire pressure should be 50 psi / 3.4 bar in the front and rear tires.

A-17

Check the Air Supply Lubricator Oil Level - Air Models



Genie specifications require that this procedure be performed every 8 hours or daily, whichever comes first.

Maintaining the proper oil level in the lubricator canister is essential to safe operation and good machine performance. Failure to keep the lubricator canister at the proper oil level could result in unsafe operating conditions and may cause component damage.

- 1 Be sure the platform is fully lowered.
- 2 Inspect the lubricator canister for proper oil level.
 - ⦿ Result: The oil level must be within ½ inch / 12.7 mm from the top of the lubricator canister.
- 3 To add oil, remove the oil lubricator canister from the lubricator base and fill with oil. Install the canister back onto the lubricator base.

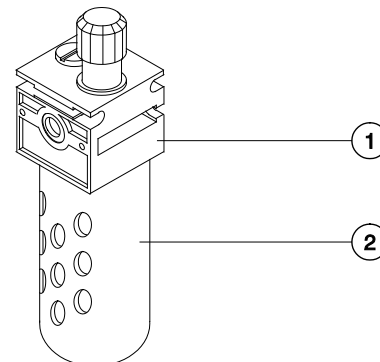

- 1 oil lubricator base
- 2 oil lubricator canister

Oil Specification

Oil Type	10W automotive engine oil
----------	---------------------------

Checklist A Procedures

A-18 Check the Air Supply Lubricator Drip Rate - Air Models



Genie specifications require that this procedure be performed every 8 hours or daily, whichever comes first.

Maintaining the proper oil drip rate into the air supply is essential to safe operation and good machine performance. Failure to maintain the proper drip rate could result in machine component damage.

- 1 While raising the platform, visually inspect the oil lubricator sight gauge.
- ⊙ Result: There should be a maximum of 1 to 2 drops of oil visible in the sight gauge.
- 2 To adjust the drip rate, turn the oil flow control valve clockwise to decrease the flow or counterclockwise to increase the flow.
- 3 Repeat this procedure until the proper oil drip rate is achieved.

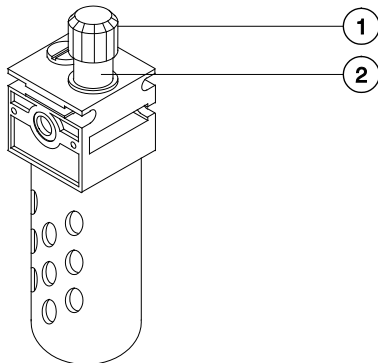

- 1 oil lubricator flow control valve
- 2 oil lubricator sight gauge

A-19 Check the Air Filter/Regulator Canister - Air Models



Genie specifications require that this procedure be performed every 8 hours or daily, whichever comes first.

It is essential to drain the air filter/regulator canister of water to ensure good air motor performance and service life. A water-filled canister could cause the air motor to perform poorly and continued use may cause component damage.

- 1 Check the air filter/regulator canister for any water accumulation.
- 2 If water is visible, loosen the drain plug at the bottom of the canister and allow the water to drain out.
- 3 Tighten the drain plug.

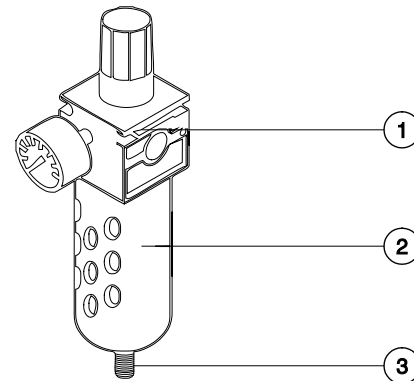

- 1 air filter/regulator
- 2 air filter/regulator canister
- 3 air filter/regulator canister drain plug

Checklist B Procedures

B-1 Inspect the Battery

Genie specifications require that this procedure be performed every 250 hours or quarterly, whichever comes first.

Proper battery condition is essential to good machine performance and operational safety. Improper fluid levels or damaged cables and connections can result in component damage and hazardous conditions.

⚠ WARNING Electrocutation/burn hazard. Contact with electrically charged circuits could result in death or serious injury. Remove all rings, watches and other jewelry.

- 1 Put on protective clothing and eye wear.
- 2 Be sure that the battery cable connections are tight and free of corrosion.

Note: Adding terminal protectors and a corrosion preventative sealant will help eliminate corrosion on the battery terminals and cables.

- 3 Remove the battery vent caps and check the specific gravity of each battery cell with a hydrometer.
 - ⊙ Result: If any battery cell displays a specific gravity of less than 1.026, the battery must be replaced.
- 4 Check the battery acid level. If needed, replenish with distilled water to the bottom of the battery fill tube. Do not overfill.
- 5 Install the battery vent caps.
- 6 If equipped: Set the battery charger AC Selector switch to the proper voltage.
- 7 Set the power switch to the AUTO position.
- 8 Result: The charger ammeter should be on.

B-2 Inspect the Electrical Wiring



Genie requires that this procedure be performed every 250 hours or quarterly, whichever comes first.

Maintaining electrical wiring in good condition is essential to safe operation and good machine performance. Failure to find and replace burnt, chafed, corroded or pinched wires could result in unsafe operating conditions and may cause component damage.

⚠ WARNING Electrocutation/burn hazard. Contact with electrically charged circuits could result in death or serious injury. Remove all rings, watches and other jewelry.

- 1 Inspect the following areas for burnt, chafed, corroded pinched and loose wires:
 - All base wiring
 - Inside ground control box
 - Hydraulic power unit
 - All external electrical cables
 - DC models: battery pack
 - AC power supply cord
 - IWP models: inside base junction box
 - IWP models: power wheel assist manifold (if equipped)

Checklist B Procedures

B-3 Inspect All Welds

Genie specifications require that this procedure be performed every 250 hours or quarterly, whichever comes first.

Weld inspections are essential to safe machine operation and good machine performance. Failure to locate and repair damage may result in an unsafe operating condition.

- 1 Visually inspect the welds in the following locations:
 - Platform
 - Base
 - Mast brace mounting bracket

AWPS models:

- Loading pivot bar
- Outrigger storage sockets
- Tilt-back frame (if equipped)
- Tilt-back frame mounting bracket (if equipped)

IWPS models:

- Foot pads
- Power wheel assist (if equipped)

B-4 Test the Tilt-back Operation (if equipped)

Genie specifications require that this procedure be performed every 250 hours or quarterly, whichever comes first.

A tilt-back frame is standard equipment on AWP-36S and 40S and optional on AWP-15S, 20S, 25S and 30S. The tilt-back frame allows the machine to be rolled through a standard doorway. Failure to detect improper tilt-back operation could result in unsafe operating conditions and may cause injury and component damage.

- 1 Fully lower the platform to the stowed position.
- 2 Remove the outriggers from the base and place in the storage sockets.
- 3 Maintain a firm grasp on the tilt-back frame and remove the retaining pin.

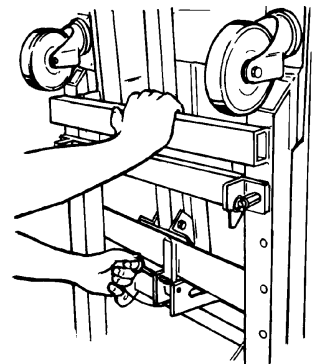

- 4 Lower the tilt-back frame and guide the tilt-back strut into the strut socket.

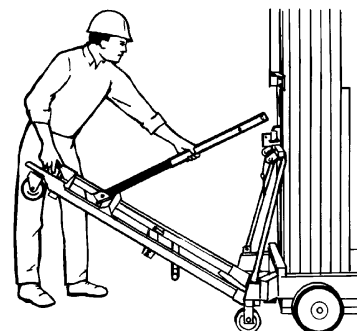

Checklist B Procedures

- 5 Insert the retaining pin into the strut socket.

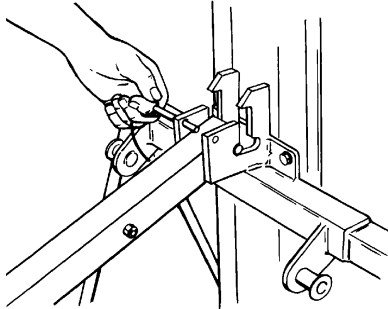

WARNING Crushing hazard. The machine will fall if the retaining pin is not locked into the strut socket.

- 6 Slide out the T-handle until the lock pin snaps into the locked position.

WARNING Crushing hazard. The machine could fall if the T-handle lock pin is not locked into the base.

- 7 Lift the machine with the T-handle to the mid-tilt position (casters on tilt-back frame contact the floor, and machine supported by the extended tilt-back strut). Use the appropriate number of people and proper lifting techniques.

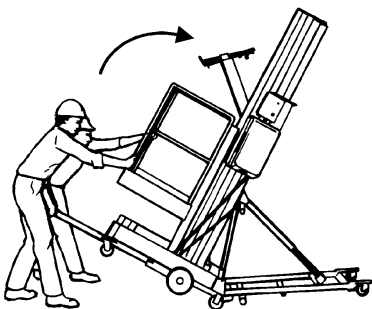

- 8 Continue lifting until telescoping tilt-back strut is completely compressed.

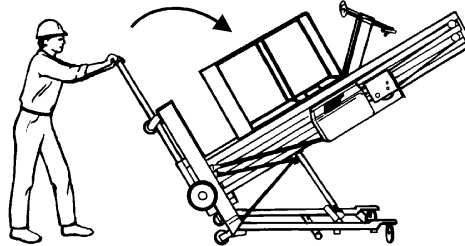

- 9 Return the machine to the standing position. Carefully pull down T-handle until machine rests at mid-tilt position.
- 10 Lower the machine with the T-handle until base casters are in contact with the ground. Use the appropriate number of people and proper lifting techniques.
- 11 Return the sliding T-handle to stowed position.
- 12 Stow the tilt-back frame in the upright position and insert the retaining pin.

Checklist B Procedures

B-5 Check the Lifting Chain Adjustment



Genie specifications require that this procedure be performed every 250 hours or quarterly, whichever comes first.

Maintaining proper adjustment of the lifting chains is essential to safe machine operation. Failure to maintain proper chain adjustment could result in unsafe operating conditions and may cause component damage.

- 1 Fully lower the platform to the stowed position.
- 2 Measure the maximum height of the machine.

IWPS models: Turn the screw jacks counterclockwise to the full up position. Pull the base lowering handle to lower the base.

- Result: The machine should be no taller than specification.

Note: If measurement does not meet specification, adjust the chains. Refer to Repair Procedure, *How to Adjust the Lifting Chains*.

- 3 **AWPS models:** Measure the distance between the top of the base frame and the bottom edge of the platform.

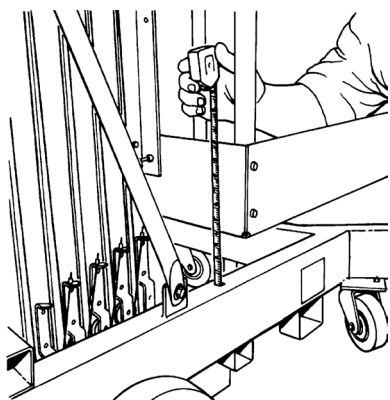

IWP models: Measure the distance between the bottom edge of the platform to the top of the counterweight.

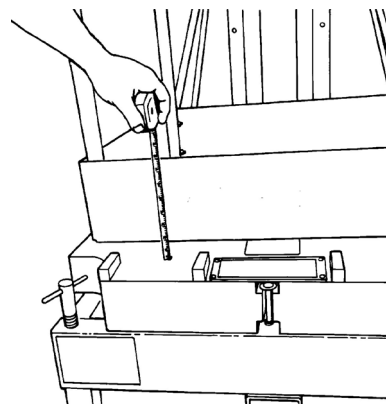

- Result: The measurement should be no less than specification.

Note: If measurement does not meet specification, adjust the chains. Refer to Repair Procedure, *How to Adjust the Lifting Chains*.

Specifications

Model	Height	Measurement (step 2)
IWP-20S	76 in	3 in
	193 cm	7.6 cm
IWP-25S	76 in	3 in
	193 cm	7.6 cm
IWP-30S	76 in	3 in
	193 cm	7.6 cm
AWP-15S	78 in	3 in
	198 cm	7.6 cm
AWP-20S	78 in	3 in
	198 cm	7.6 cm
AWP-25S	78 in	3 in
	198 cm	7.6 cm
AWP-30S	78 in	3 in
	198 cm	7.6 cm
AWP-36S	109 ½ in	3 in
	278 cm	7.6 cm
AWP-40S	109 ½ in	3 in
	278 cm	7.6 cm



Checklist B Procedures

B-6 Clean and Lubricate the Columns



Genie requires that this procedure be performed every 250 hours or quarterly, whichever comes first.

Clean and properly lubricated columns are essential to good machine performance and safe operation. Extremely dirty conditions may require that the columns be cleaned and lubricated more often.

- 1 Raise the platform to the maximum height.
- 2 Visually inspect the inner and outer channels of the columns for debris or foreign material. If necessary, use a mild cleaning solvent to clean the columns.

⚠ WARNING Bodily injury hazard. This procedure will require the use of additional access equipment. Do not place ladders or scaffold on or against any part of the machine. Performing this procedure without the proper skills and tools could result in death or serious injury. Dealer service is strongly recommended.

- 3 If needed, apply a generous amount of Boe-lube wax (Genie part number 90337) to the inside and outside channels of each column.

B-7 Test the Lifting Capacity



Genie requires that this procedure be performed every 250 hours or quarterly, whichever comes first.

Proper lifting capacity is essential to safe machine operation. Improper lifting capacity adjustment could allow machine to be overloaded and may cause death or serious injury.

⚠ WARNING Bodily injury hazard. This procedure requires specific repair skills, lifting equipment and a suitable workshop. Attempting this procedure without these skills and tools could result in death or serious injury and significant component damage. Dealer service is strongly recommended.

- 1 Place the maximum rated load in the platform. Secure the load to the platform.

Note: Refer to the operator's manual or the load capacity decal on the machine to determine the maximum load capacity.

- 2 Raise the platform slightly.
 - ⦿ Result: The hydraulic power unit should raise the platform.
- 3 Fully lower the platform.
- 4 Add additional weight to the platform that is equal to, but does not exceed 20% of the maximum rated load. Secure the additional weight. Refer to the machine serial plate.
- 5 Raise the platform slightly.
 - ⦿ Result: The hydraulic power unit should not be able to raise the platform.
- 6 Note: If the hydraulic power unit is unable to lift rated load or lifts more than rated load, refer to Repair Procedure, *Valve Adjustment*.

Checklist B Procedures

B-8 Adjust the Sequencing Cables



Genie requires that this procedure be performed every 250 hours or quarterly, whichever comes first.

Maintaining proper adjustment of the sequencing cables is essential for safe machine operation. An unsafe working condition exists if the sequencing cables are improperly adjusted. A daily check of the sequencing cables allows the inspector to identify changes in the operating condition that might indicate damage.

To serial number 3899-11843

- 1 Fully lower the platform.
- 2 Check the deflection on each sequencing cable by grasping the cable halfway down the column and pulling the cable to one side then the other. Measure the total distance between the two points (this is the maximum deflection)

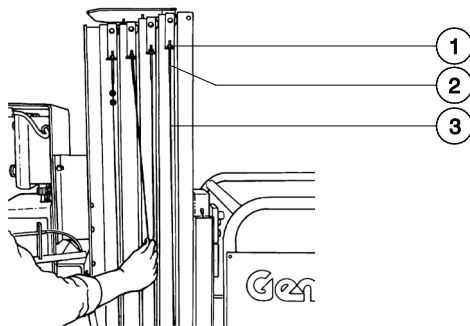

- 1 adjustment (tension) nut
- 2 threaded swage end
- 3 sequencing cable

- 3 If needed, adjust the sequencing cable deflection.

- 4 Hold the threaded swage end of the cable from turning and adjust the tension nut to obtain correct deflection. Turn the adjustment nut clockwise to decrease the deflection or counterclockwise to increase the deflection.

NOTICE Component damage hazard. Do not exceed the recommended deflection.

- 5 Raise and lower the platform through three complete cycles and confirm deflection.
- 6 Repeat adjustment for each cable as required.

Deflection, Maximum	1 ½ to 2 ½ inches 3.8 to 6.4 cm
----------------------------	------------------------------------

After serial number 3899-11843

- 1 Fully lower the platform.
- 2 Check for proper deflection of each sequencing cable by inspecting the spring compression. The spring is located between the nylock nut and the upper sequencing bracket.

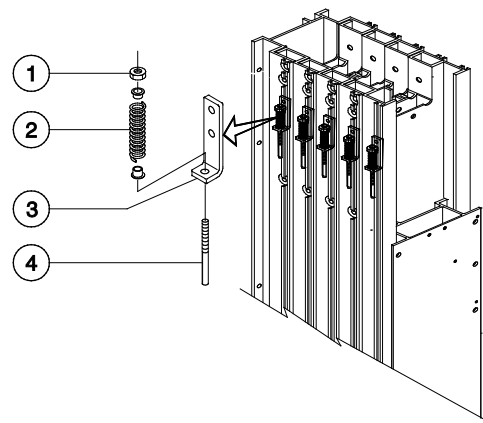

- 1 nylock nut
- 2 spring
- 3 upper sequencing bracket
- 4 sequencing cable



Checklist B Procedures

- 3 Compress the spring to 15/16 in / 2.4 cm by turning the nylock nut clockwise to increase the spring compression or counterclockwise to decrease the spring compression.

NOTICE Component damage hazard. Do not exceed the recommended spring compression.

- 4 Confirm the spring measurement on each sequencing cable.
- 5 Raise and lower the platform through three complete cycles and confirm the spring compression.
- 6 Repeat adjustment for each cable as required.

B-9

Inspect for Proper Outrigger Length - AWPS Models



Genie specifications require that this procedure be performed every 250 hours or quarterly, whichever comes first.

Proper outrigger length is essential to safe machine operation. Operating a machine with outriggers different from those originally designed for the model will result in death or serious injury.

- 1 Measure each outrigger and verify for proper length.

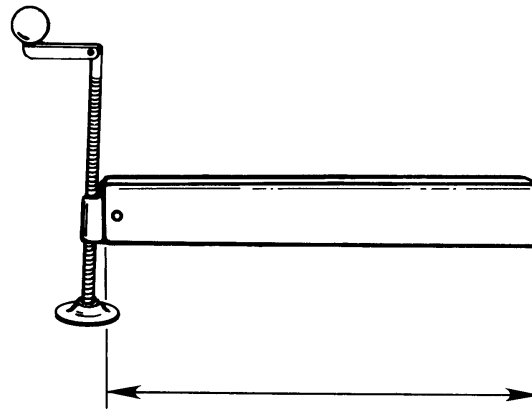

Checklist B Procedures

ANSI / CSA Models

AWP-15S (including narrow and rough terrain base options)	20 inches 50.8 cm
AWP-20S (including narrow and rough terrain base options)	20 inches 50.8 cm
AWP-25S (including narrow and rough terrain base option)	20 inches 50.8 cm
AWP-30S (including narrow and rough terrain base option)	26 inches 66 cm
AWP-36S	36 inches 91.4 cm
AWP-40S	40 inches 101.6 cm

CE / AS Models

AWP-15S	20 inches 50.8 cm
AWP-20S	20 inches 50.8 cm
AWP-20S (narrow and rough terrain base options)	26 inches 66 cm
AWP-25S (including narrow and rough terrain base option)	26 inches 66 cm
AWP-30S (including narrow and rough terrain base option)	31 inches 79 cm
AWP-30S (narrow and rough terrain base with air power option)	36 inches 91.4 cm
AWP-36S	36 inches 91.4 cm
AWP-40S	40 inches 102 cm

Checklist B Procedures

B-10 Inspect and Lubricate the Outrigger Leveling Jack Footpads - AWPS Models



Genie requires that this procedure be performed every 250 hours or quarterly, whichever comes first.

Detection of unusual wear of the leveling jack footpads is essential for safe machine operation. An improperly lubricated and or damaged footpad could result in an unsafe condition.

- 1 Visually inspect the leveling jack footpads for any unusual wear.
- 2 Liberally apply grease to the top of the footpads at the swivel point and the leveling jack threads.

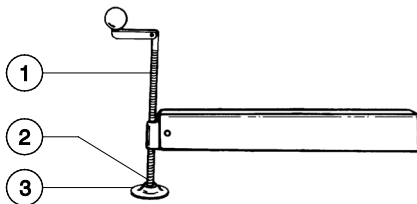

- 1 outrigger leveling jack threads
- 2 outrigger footpad swivel point
- 3 outrigger footpad

Grease Type	Lithium-based
-------------	---------------

B-11 Test the Level Sensing Operation - IWPS Models



Genie requires that this procedure be performed every 250 hours or quarterly, whichever comes first.

Detection of level sensing malfunctions is essential for safe machine operation. An improperly functioning level sensing system could result in unsafe operating conditions.

- 1 Position the machine on a firm, level surface
- 2 Turn the key switch to ground control and pull out the red Emergency Stop button to the ON position. Twist to release the red Emergency Stop button at the platform controls.
 - ⦿ Result: The power light should be on.
- 3 Adjust the leveling jacks until the bubble is in the center ring of the bubble level and all four foot pads are in firm contact with the ground.
 - ⦿ Result: Within 1 to 4 seconds, all four interlock display lights should turn on and remain on.
- 4 Pump the foot pedal to raise the base.
- 5 Place a ¼ inch / 6.35 mm thick spacer under one adjustable and one non-adjustable foot pad on the same side of the machine.
- 6 Pull the base lowering handle to fully lower the base.
 - ⦿ Result: Within 1 to 4 seconds, all four interlock display lights should turn on and remain on.

Checklist B Procedures

- 7 Repeat steps 4 and 5 using a ½ inch / 12.7 mm spacer.
- 8 Pull the base lowering handle to fully lower the base.
 - ⊙ Result: Within 1 to 4 seconds, two interlock display lights should turn off and remain off.
- 9 Repeat steps 4 through 8 to test the opposite side of the machine.
- 10 Pump the foot pedal to raise the base.
- 11 Place a ¾ inch / 19 mm thick spacer under both adjustable foot pads.
- 12 Pull the base lowering handle to fully lower the base.
 - ⊙ Result: Within 1 to 4 seconds, all four interlock display lights should turn on and remain on.
- 13 Pump the foot pedal to raise the base.
- 14 Turn the leveling jacks counterclockwise enough to fit a 1½ inch / 3.8 cm spacer under each adjustable foot pad.
- 15 Turn the leveling jacks clockwise until the foot pads just touch the spacers.
- 16 Pull the base lowering handle to fully lower the base.
 - ⊙ Result: Within 1 to 4 seconds, two interlock display lights should turn off and remain off.
- 17 Pump the foot pedal to raise the base.
- 18 To test the non-adjustable foot pads, turn the leveling jacks counterclockwise all the way.
- 19 Place a 1½ inch / 3.8 cm spacer under each non-adjustable foot pad.
- 20 Pull the base lowering handle to fully lower the base.
 - ⊙ Result: Within 1 to 4 seconds, two interlock display lights should turn off and remain off.

B-12

Check the Chain Adjustment, IWP-20S Models with Outreach Option



Genie requires that this procedure be performed every 250 hours or quarterly, whichever comes first.

Detection of a improperly adjusted platform outreach chain is essential for safe machine operation. Failure to detect an improperly adjusted platform outreach chain could result in unsafe operating conditions and may cause injury and component damage.

- 1 Fully lower the platform.
- 2 Lower the base and turn the key switch off.
- 3 Fully extend the outreach and lock the handle.
- 4 Locate the chain between the lower sprocket and the lower brace.
- 5 Grasp the two chain sections and lightly pinch them together.
 - ⊙ Result: There should be a minimum of a ¼ inch / 6.4 mm gap between the chain sections.

Note: If measurement does not meet specification, adjust the chains. Refer to Repair Procedure, *How to Adjust the Platform Outreach Chain*.

Checklist C Procedures

C-1 Inspect and Lubricate the Casters and Wheels



Genie specifications require that this procedure be performed every 1000 hours or annually, whichever comes first.

Extremely dirty conditions may require that the casters and wheels be inspected and lubricated more often.

- 1 Visually inspect each caster and wheel for cuts, cracks or unusual wear.
- 2 Push the machine on a flat smooth surface and check that the casters and wheels roll smoothly.
- 3 Pump grease into the zerk fitting on each caster and wheel until it can be seen coming out of the bearing seal gap.

Grease Type	Lithium-based
-------------	---------------

C-2 Inspect the Mast Assembly for Wear



Genie specifications require that this procedure be performed every 1000 hours or annually, whichever comes first.

Detection of excessive or unusual wear in the mast assembly is essential for safe machine operation. An unsafe working condition exists if the mast assembly has excessive wear or does not operate smoothly, free of hesitation and binding.

- 1 Remove the mast covers.
 - 2 Raise the platform until 3 to 5 inches / 7.6 to 12.7 cm of each column is visible.
 - 3 Visually inspect the top of each column for clearance between the roller wheels and the adjacent column surface.
- ⊙ Result: There should be a equal amount of distance between the roller wheel and the column on each side.

Note: If mast inspection results in a measurement that is not within specification, refer to Repair Procedure, *How to Adjust the Glide Pads*.

Checklist C Procedures

- 4 Loosen but do not remove the adjustment nut on the sequencing cable located at the top of the first column.

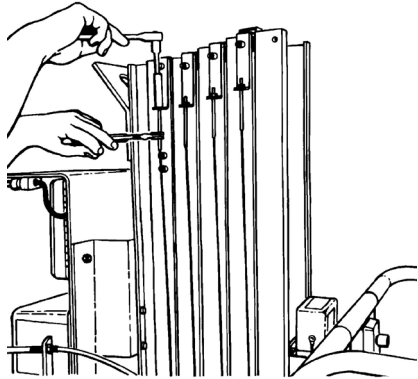

- 5 Raise the platform approximately 3 feet / 1 m above the top of the base.
- 6 Place a jack stand on the top of the base, centered under the platform. Adjust the jack stand to 24 inches / 61 cm.

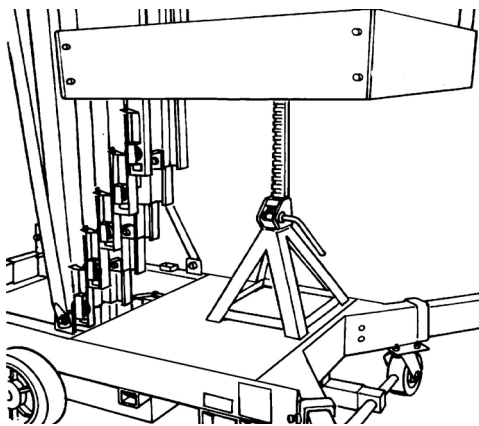

- 7 Lower the platform onto the jack stand just enough to take the weight off the lifting chains.

⚠ WARNING

Crushing hazard. Keep away from lowering platform.

- 8 Inspect each idler wheel for the following:

- Excessive wear on the side flanges
- Unusual wear
- Movement side to side in excess of 0.079 inch / 2 mm
- Any movement of wheel front to back

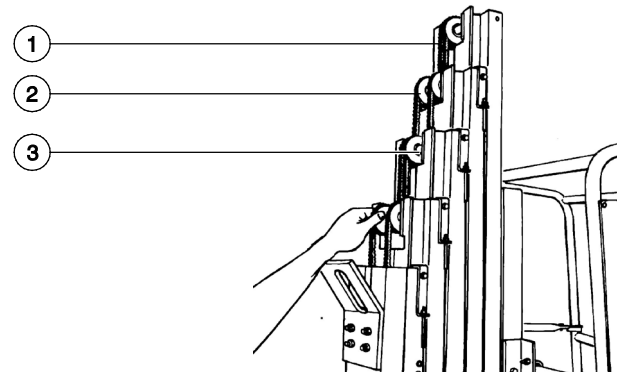

- 1 Chain
- 2 Idler Wheel
- 3 Spacer

Note: If idler wheel inspection results in a measurement that is not within specification, replace the idler spacers. Refer to Repair Procedure, *How to Assemble the Mast*.

- 9 Raise the platform and remove the jack stand and the support blocks. Then lower the platform.
- 10 Install the mast covers and adjust the sequencing cable. Refer to Maintenance Procedure, *Adjust the Sequencing Cables*.

Checklist C Procedures

C-3 Inspect and Lubricate the Lifting Chains

Genie specifications require that this procedure be performed every 1000 hours or annually, whichever comes first.

Lubricated chains are essential to good machine performance and safe operation. Extremely dirty conditions may require that the chains be cleaned and lubricated more often.

- 1 Raise the platform to the maximum height.
- 2 Inspect each lifting chain. Refer to Repair Procedure, *How to Inspect the Lifting Chains*.
- 3 Lubricate each chain with a dry-type spray lubricant.

▲ WARNING Bodily injury hazard. This procedure will require the use of additional access equipment. Do not place ladders or scaffold on or against any part of the machine. Performing this procedure without the proper skills and tools could result in death or serious injury. Dealer service is strongly recommended.

C-4 Replace the Hydraulic Oil

Genie specifications require that this procedure be performed every 1000 hours or annually, whichever comes first.

Replacement or testing of the hydraulic oil is essential for good machine performance and service life. Dirty oil and a clogged suction strainer may cause the machine to perform poorly and continued use may cause component damage. Extremely dirty conditions may require oil changes to be performed more often. For hydraulic oil specifications, Refer to Specifications, *Hydraulic Specifications*.

- 1 Fully lower the platform.
- 2 Remove the plastic cover from the power unit.
- 3 Remove the drain plug from the tank and allow all of the oil from the tank to drain into a suitable container.

▲ WARNING Bodily injury hazard. Spraying hydraulic oil can penetrate and burn skin. Loosen hydraulic connections very slowly to allow the oil pressure to dissipate gradually. Do not allow oil to squirt or spray.

- 4 IWPS models with Power Wheel Assist Option: Tag and disconnect the hose at the bottom of the tank and drain oil into a suitable container.

▲ WARNING Bodily injury hazard. Spraying hydraulic oil can penetrate and burn skin. Loosen hydraulic connections very slowly to allow the oil pressure to dissipate gradually. Do not allow oil to squirt or spray.

Checklist C Procedures

- 5 Remove the tank from the hydraulic power unit.
- 6 Remove the suction strainer from the pick-up tube and the magnet from inside the tank and clean them using a mild solvent.
- 7 Install the suction strainer.
- 8 Install the drain plug using thread sealer on the threads.
- 9 Install the hydraulic tank.
- 10 Fill the tank with hydraulic oil until the level is visible in the sight gauge on the side of the tank. Do not overfill.
- 11 Replace the breather cap with a new one.
- 12 Raise and lower the platform through three complete cycles. Add hydraulic oil if needed to allow platform to reach full height.
- 13 Clean up any oil that may have spilled. Properly discard the used oil.

NOTICE

Component damage hazard. Do not allow the hydraulic tank to completely empty when raising the platform. Pressurized air in the hydraulic system can damage hydraulic components.

Hydraulic System

Hydraulic fluid	Chevron Rando HD equivalent
Hydraulic tank capacity - all models	3 quarts 2.8 liters

Hydraulic System Capacity (includes tank)

IWP AC and DC models

IWP-20S	3.7 quarts 3.5 liters
IWP-25S	3.7 quarts 3.5 liters
IWP-30S	3.7 quarts 3.5 liters

AWP AC, DC and Air Powered models

AWP-15S	3.7 quarts 3.5 liters
AWP-20S	3.7 quarts 3.5 liters
AWP-25S	3.7 quarts 3.5 liters
AWP-30S	3.7 quarts 3.5 liters
AWP-36S	4 quarts 3.8 liters
AWP-40S	3.9 quarts 3.7 liters

Checklist C Procedures

C-5 Replace the Auxiliary Platform Lowering Batteries



Genie specifications require that this procedure be performed every 1000 hours or annually, whichever comes first.

- 1 Turn the key switch off and remove the key.
- 2 Remove the ground control box cover fasteners.
- 3 Open the ground control box and locate the auxiliary battery pack inside.
- 4 Remove the fasteners that hold the battery pack in place.
- 5 Carefully slide the battery pack out of the holder.

Note: The wires connected to the battery pack are very small. Be careful not to damage the wires.

- 6 Remove the old batteries from the pack.
- 7 Insert new batteries into the pack.

Note: Make sure the batteries are installed correctly by following the diagram on the inside of the battery pack.

- 8 Install the battery pack into the ground control box and tighten the fasteners.
- 9 Close the ground control box cover and tighten the fasteners. Do not overtighten.

This page intentionally left blank.



Repair Procedures



Observe and Obey:

- Repair procedures shall be completed by a person trained and qualified on the repair of this machine.
- Immediately tag and remove from service a damaged or malfunctioning machine.
- Repair any machine damage or malfunction before operating the machine.

Before Repairs Start:

- Read, understand and obey the safety rules and operating instructions in the appropriate operator's manual on your machine.
- Be sure that all necessary tools and parts are available and ready for use.
- Use only Genie approved replacement parts.
- Read each procedure completely and adhere to the instructions. Attempting shortcuts may produce hazardous conditions.

Machine Configuration:

- Unless otherwise specified, perform each repair procedure with the machine in the following configuration:
 - Machine parked on a firm, level surface
 - Key switch in the off position with the key removed
 - The red Emergency Stop button in the off position at both the ground and platform controls
 - Wheels chocked
 - All external AC power supply disconnected from the machine
 - Platform in the stowed position

Repair Procedures

About This Section

Most of the procedures in this section should only be performed by trained service professional in a suitably equipped workshop. Select the appropriate repair procedure after troubleshooting the problem.

Perform disassembly procedures to the point where repairs can be completed. Then to re-assemble, perform the disassembly steps in reverse order.

Symbols Legend



Safety alert symbol—used to alert personnel to potential personal injury hazards. Obey all safety messages that follow this symbol to avoid possible injury or death.

⚠ DANGER

Indicates a imminently hazardous situation which, if not avoided, will result in death or serious injury.

⚠ WARNING

Indicates a potentially hazardous situation which, if not avoided, could result in death or serious injury.

⚠ CAUTION

Indicates a potentially hazardous situation which, if not avoided, may cause minor or moderate injury.

NOTICE

Indicates a potentially hazardous situation which, if not avoided, may result in property damage.

- ⦿ Indicates that a specific result is expected after performing a series of steps.
- ⊗ Indicates that an incorrect result has occurred after performing a series of steps.

Base Assembly

1-1 Interlocks

AWPS models: The interlock contacts indicate proper installation of the outriggers and only allow the machine to operate when the outriggers are properly installed and adjusted.

IWPS models: The base interlock switches indicate that the foot pads are in firm contact with the ground.

How to Remove an Interlock Contact - AWP Models

- 1 Fully lower the platform.
- 2 Turn the key switch off and remove the key.
- 3 Store the outriggers in the storage sockets.
- 4 Remove the rear base cover.

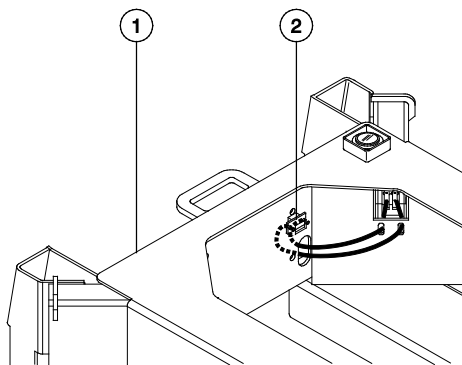

- 1 base
2 terminal switch

- 5 Trace the interlock contact wires to the rear of the base.
- 6 Locate the terminal strip.
- 7 Label and remove the contact wires by inserting a small screwdriver into the hole below the wire and gently push in while pulling on the wire.

- 8 Follow the wires to the grommets where the wire enters and exits the base. Pull the wires through the grommets and the base.

Note: Only pull the wires out far enough to access the interlock contact bracket mounting fasteners.

- 9 Remove the interlock contact bracket mounting fasteners from the outrigger base socket.

How to Remove a Base Interlock Switch - IWPS Models

- 1 Fully lower the platform.
- 2 Turn the key switch off and remove the key.
- 3 Pull the base lowering handle to fully lower the base.
- 4 Remove the foot pad switch bracket fasteners.
- 5 Pull the foot pad switch bracket out of the base.

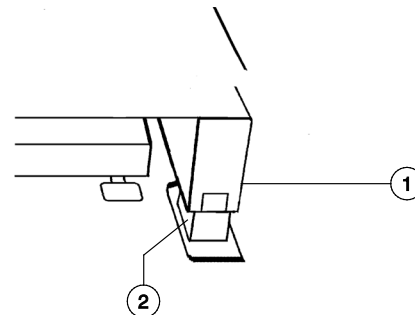

- 1 switch bracket cover
2 switch bracket fasteners

- 6 Remove the wires from the switch. Note the wire positions.
- 7 Remove the fastener that attaches the switch to the switch bracket.

Base Assembly

1-2 Base Components IWPS Models

How to Remove the Inner Base Frame

⚠ WARNING Bodily injury hazard. This procedure requires specific repair skills, lifting equipment and a suitable workshop. Attempting this procedure without these skills and tools could result in death or serious injury and significant component damage. Dealer service is strongly recommended.

- 1 Pull the base lowering handle to fully lower the base.
- 2 Attach an overhead crane to the lifting eye at the top of the mast.
- 3 Remove the mounting fastener from the lift cylinder rod end. Lift the rod end of the cylinder up and attach it to the base.
- 4 Tag, disconnect and plug the three hydraulic hoses from the base manifold. Cap the ports on the manifold

⚠ WARNING Bodily injury hazard. Spraying hydraulic oil can penetrate and burn skin. Loosen hydraulic connections very slowly to allow the oil pressure to dissipate gradually. Do not allow oil to squirt or spray.

- 5 Pull the hoses through the channel of the base inner frame.

- 6 From under the base, remove the inner frame support tube mounting fasteners. The tube is mounted directly under the number 1 column.
- 7 Carefully lift the machine off of the inner base frame. Do not allow the inner base frame to fall when lifting the machine

⚠ WARNING Crushing hazard. The machine may fall, if it is not properly supported by the overhead crane when removed from the base.

Base Assembly

How to Adjust the Base Release Cable

- 1 Pull the base lowering handle to fully lower the base.
- 2 Remove the cover from the base manifold.
- 3 Be sure the cable is properly connected to the manual valve at the base manifold.

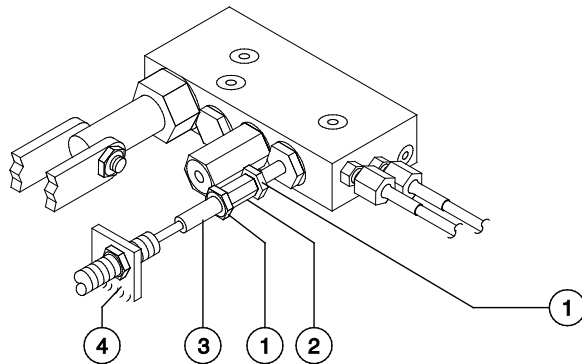

- 1 lock nut
- 2 coupler
- 3 base release cable
- 4 cable mounting bracket

- 4 Be sure the cable is attached to the cable mounting bracket with a lock nut on each side. There should be $\frac{1}{4}$ to $\frac{1}{2}$ inch / 6.35 to 12.7 mm of threads on the manifold side of the bracket.

- 5 Locate the base release cable mounting bracket on the bottom side of the number 1 column.

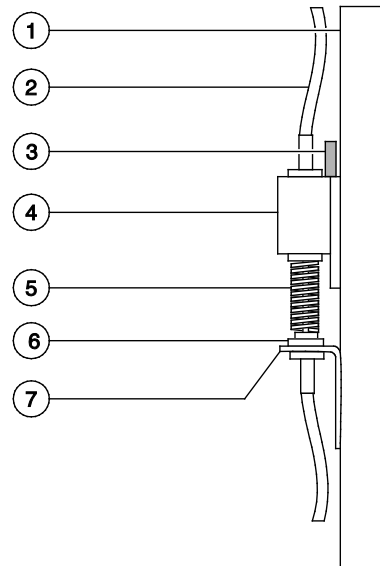

- 1 number 1 column
- 2 base release cable
- 3 cable striker bracket
- 4 slider bracket
- 5 spring
- 6 lock nut
- 7 cable mounting bracket

- 6 Loosen the mounting fasteners on the cable mounting bracket and the cable striker bracket on the number 1 column. Do not remove the fasteners.

Base Assembly

- 7 Measure from the bottom of the number 1 column, make a reference mark 6 inches / 15.2 cm up the column.
- 8 Slide the cable mounting bracket up, until the top of the bracket is even with the reference mark from step 7. Tighten the mounting fasteners.
- 9 Measure from the bottom of the number 2 column, make a reference mark 10 inches / 25.4 cm up the column.
- 10 Slide the cable striker bracket down until the top of the bracket is even with the reference mark from step 9. The spring will need to be compressed, when the cable striker bracket is pulled down. Tighten the mounting fasteners.
- 11 Pump the foot pedal to raise the base.
- 12 Pull the base release handle to be sure the base lowers. Adjust if necessary.

How to Adjust the Foot Pump Pressure Relief Valve

NOTICE Component damage hazard. The work area and surfaces where this procedure will be performed must be clean and free of debris that could get into the hydraulic system.

- 1 Pull the base lowering handle to fully lower the base.
- 2 Tag and disconnect the hydraulic hose from the port at the rod end of the base cylinder. Cap the cylinder port

⚠ WARNING Bodily injury hazard. Spraying hydraulic oil can penetrate and burn skin. Loosen hydraulic connections very slowly to allow the oil pressure to dissipate gradually. Do not allow oil to squirt or spray.

- 3 Connect a 0 to 3000 psi / 0 to 250 bar pressure gauge to the hydraulic hose.
- 4 Slowly pump the foot pedal and note the pressure
 - ⦿ Result: The pressure gauge should read 1600 psi \pm 50 psi / 110 bar \pm 3.4 bar. Adjust if necessary.
- 5 Remove the manifold cover.
- 6 Hold the lift relief valve with a wrench and remove the cap (schematic item J).
- 7 Adjust the internal hex socket. Turn it clockwise to increase the pressure or counterclockwise to decrease the pressure.
- 8 Install the relief valve cap.

⚠ DANGER Tip-over hazard. Do not adjust the relief valve higher than specified.

- 9 Repeat step 4 to confirm the relief valve setting. Re-adjust if necessary.

Base Assembly

How to Remove the Foot Pump

NOTICE Component damage hazard.
The work area and surfaces where this procedure will be performed must be clean and free of debris that could get into the hydraulic system.

- 1 Pull the base lowering handle to fully lower the base.
- 2 Remove the linkage mounting fasteners from the foot pump.
- 3 Remove the foot pump from the manifold. Plug the port in the manifold.

Note: The foot pump must be bled after installation.

How to Bleed the Foot Pump

- 1 Pull the base lowering handle to fully lower the base.
- 2 Place a container under the base lowering cylinder, and remove the bleed screw from the barrel-end of the base lowering cylinder.
- 3 Pump the foot pedal until air stops coming out of the bleed screw hole.
- 4 While holding the foot pedal down, install the bleed screw.
- 5 Release the foot pedal.
- 6 Check the sight gauge on the side of the hydraulic tank.
- 7 Add oil if needed. Do not overfill.
- 8 Clean up any oil that may have spilled. Properly discard the used oil.

Base Assembly

1-3

Foot Pump Manifold Components - IWPS Models (to SN IWP09-8269)

Index No.	Description	Schematic Item	Function	Torque
1	Check valve	G	System pressure	8-10 ft-lbs / 11-14 Nm
2	Check valve	H	Directs flow to the tank	
3	Manual release valve	I	Lowers base	8-10 ft-lbs / 11-14 Nm
4	Relief valve, 1600 psi / 110 bar	J	Base lift cylinder	35-40 ft-lbs / 47-54 Nm
5	Pilot to open check valve	K	Base lift cylinder	35-40 ft-lbs / 47-54 Nm
6	Foot pump	L	Base lift cylinder	8-10 ft-lbs / 11-14 Nm

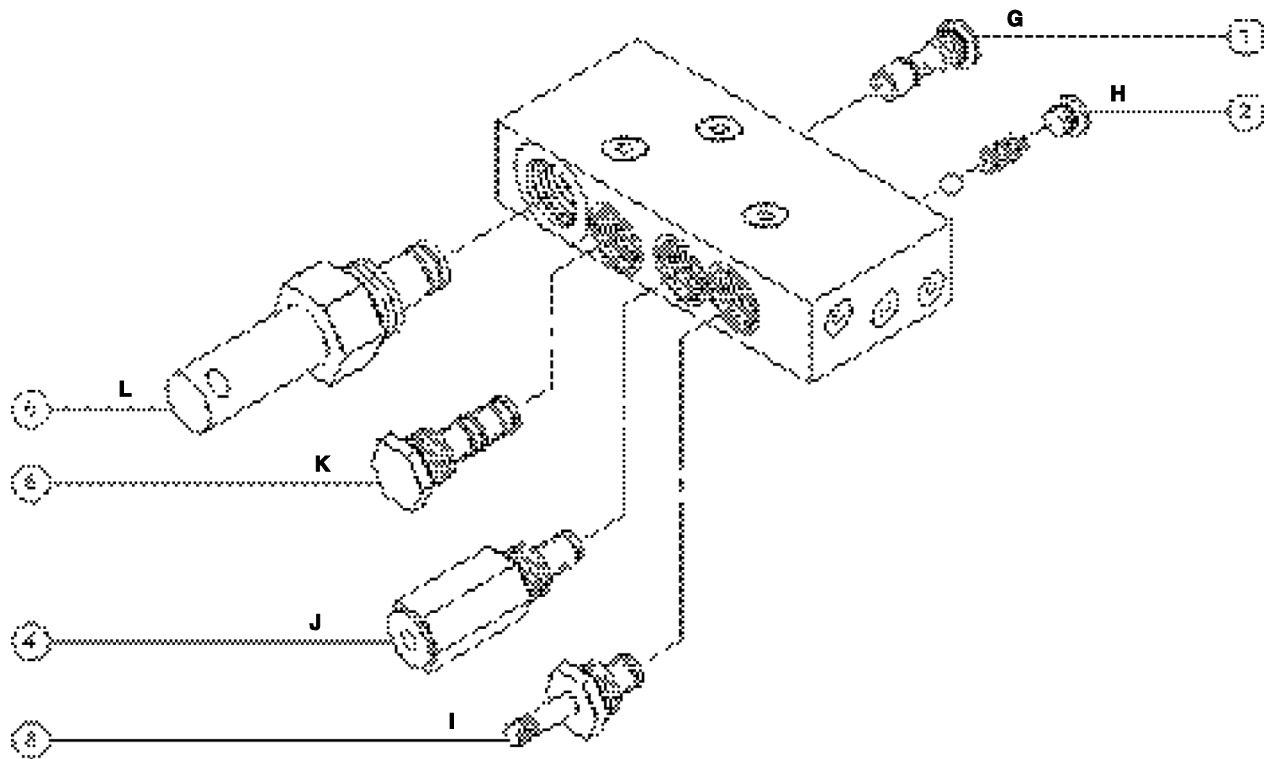

Base Assembly

1-4 Foot Pump Manifold Components - IWPS Models (from SN IWP09-8270)

Index No.	Description	Schematic Item	Function	Torque
1	Plug, SAE No. 6			17-19 ft-lbs / 23-25 Nm
2	Check valve	H	Directs flow to the tank	8-10 ft-lbs / 11-14 Nm
3	Plug, SAE No. 4			12-14 ft-lbs / 17-19 Nm
4	Manual release valve	I	Lowers base	8-10 ft-lbs / 11-14 Nm
5	Plug, SAE No. 6			17-19 ft-lbs / 23-25 Nm
6	Relief valve, 1600 psi / 110 bar	J	Base lift cylinder	8-10 ft-lbs / 11-14 Nm
7	Check valve	G	System pressure	8-10 ft-lbs / 11-14 Nm
8	Plug, SAE No. 6			17-19 ft-lbs / 23-25 Nm
9	Pilot to open check valve	K	Base lift cylinder	35-40 ft-lbs / 47-54 Nm
10	Foot pump	L	Base lift cylinder	8-10 ft-lbs / 11-14 Nm
11	Orifice, 0.3 inch / 0.76 mm	M	Foot Pump	

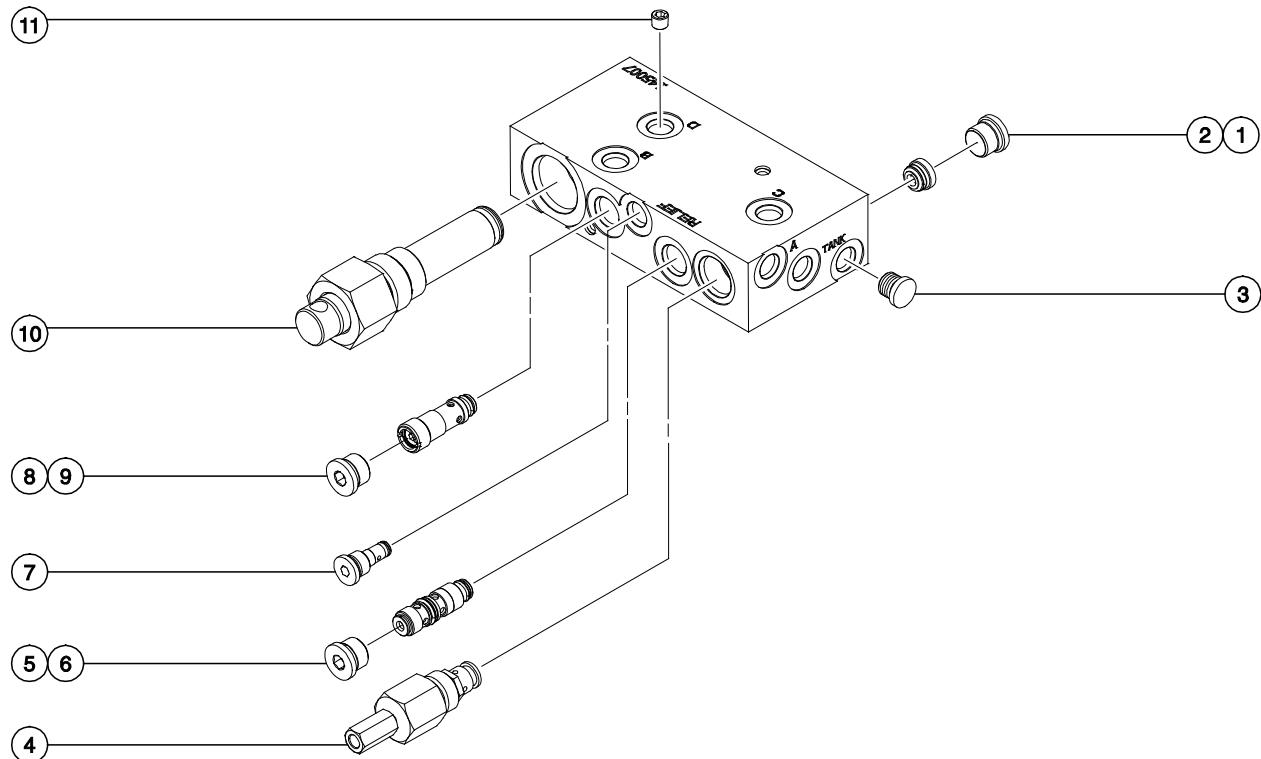

Base Assembly

1-5

Power Wheel Assist Manifold Components - IWPS Models (to SN 4097-990)

Index No.	Description	Schematic Item	Function	Torque
1	Check valve	AA	System pressure	25-35 ft-lbs / 34-41 Nm
2	Solenoid valve, 2 position 3 way	AB	Reverse	25-35 ft-lbs / 34-41 Nm
3	Solenoid valve, 2 position 3 way	AC	Forward	25-35 ft-lbs / 34-41 Nm
4	Solenoid valve, 2 position 3 way	AD	All functions	25-35 ft-lbs / 34-41 Nm

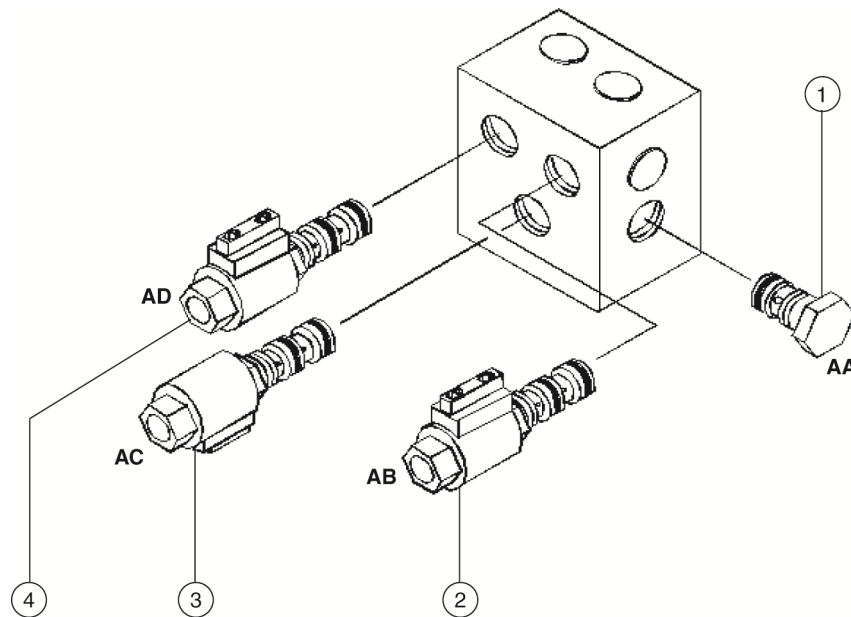

Base Assembly

1-6

Power Wheel Assist Manifold Components - IWPS Models (from SN 4097-991 to 4099-2532)

Index No.	Description	Schematic Item	Function	Torque
1	Check valve	BA	System pressure	25-35 ft-lbs / 34-41 Nm
2	Solenoid Valve, 2 position 2 way	BB	All Functions	25-35 ft-lbs / 34-41 Nm
3	Solenoid Valve, 3 position 4 way	BC	Forward/Reverse	25-35 ft-lbs / 34-41 Nm
4	Relief Valve 1600 psi / 110 bar	BD	System relief	25-35 ft-lbs / 34-41 Nm

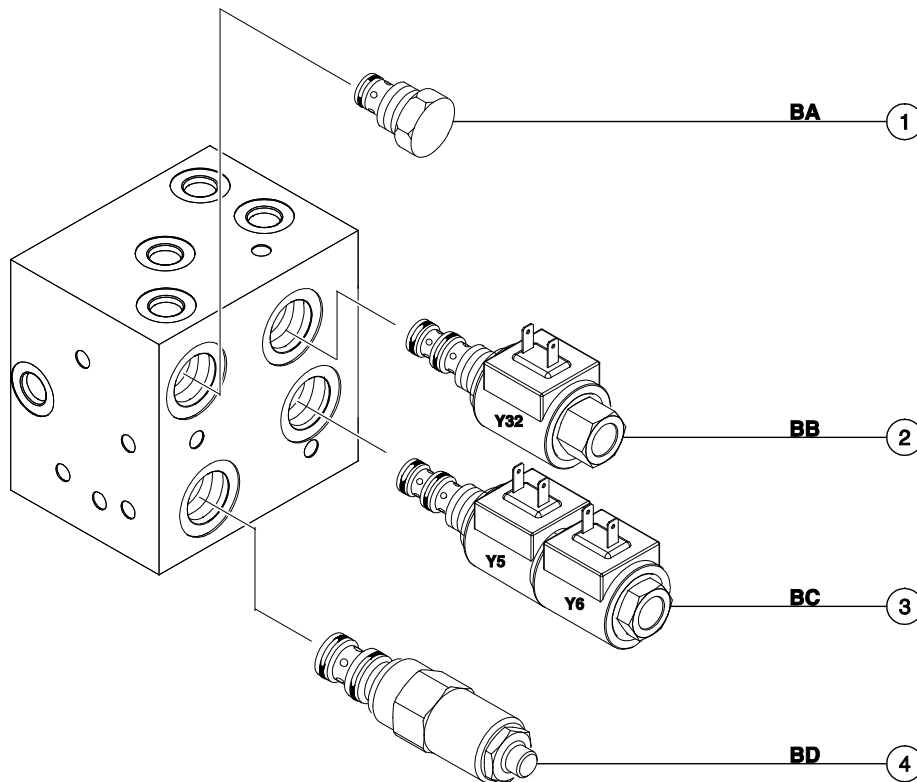

Base Assembly

1-7

Power Wheel Assist Manifold Components - IWPS Models (from SN 4099-2533)

Index No.	Description	Schematic Item	Function	Torque
1	Check valve	CA	System pressure	25-35 ft-lbs / 34-41 Nm
2	Solenoid valve, 2 position 2 way	CB	All functions	25-35 ft-lbs / 34-41 Nm
3	Solenoid valve, 3 position 4 way	CC	Forward/Reverse	25-35 ft-lbs / 34-41 Nm
4	Relief valve 1600 psi / 110 bar	CD	System relief	25-35 ft-lbs / 34-41 Nm
5	Cross-port relief valve	CE	Brake	25-35 ft-lbs / 34-41 Nm

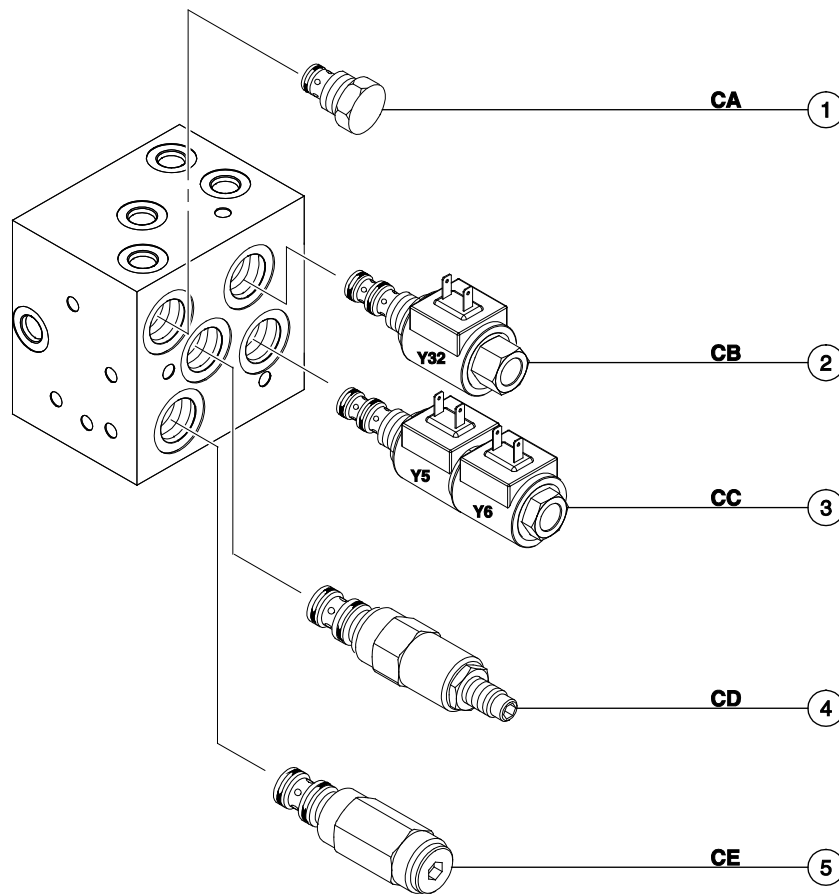

Ground Controls

2-1 How to Test the Transformer - AC Models

- 1 Fully lower the platform.
- 2 Turn the key switch off and disconnect the power supply.
- 3 Open the ground control box and locate the transformer.
- 4 Tag and disconnect all wiring from the transformer.
- 5 Connect the leads from an ohmmeter to the following terminal combinations and check the continuity/resistance.

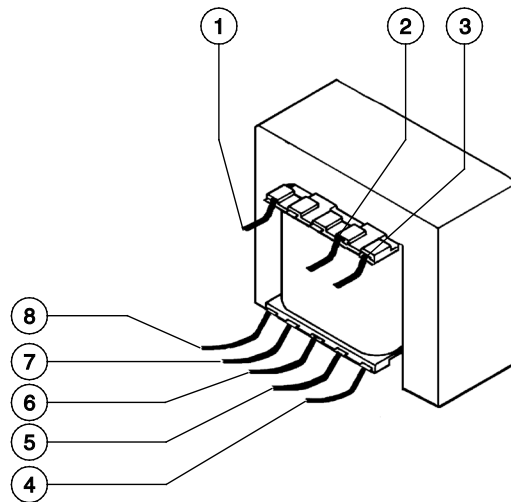

- 1 red wire #2
- 2 red/yellow wire
- 3 red wire #1
- 4 yellow wire
- 5 black wire
- 6 white wire
- 7 brown wire
- 8 blue wire

Test	Desired result
brown wire to blue wire	20 to 22Ω
black wire to white wire	16 to 19Ω
yellow wire to white wire	16 to 19Ω
red/yellow wire to red wire #1	0.5 to 1.5Ω
red/yellow wire to red wire #2	0.5 to 1.5Ω
red wire #1 to red wire #2	0.5 to 1.5Ω
yellow wire to black wire	0.5 to 1.5Ω
all other wire combinations	no continuity (infinite Ω)

Ground Controls

2-2 How to Test the AC Contactor - AC Models

- 1 Fully lower the platform.
- 2 Turn the key switch off and disconnect the power supply.
- 3 Open the ground control box and locate the AC contactor.
- 4 Tag and disconnect all wiring from the contactor.
- 5 Connect the leads from an ohmmeter to the following terminal combinations and check the continuity/resistance.

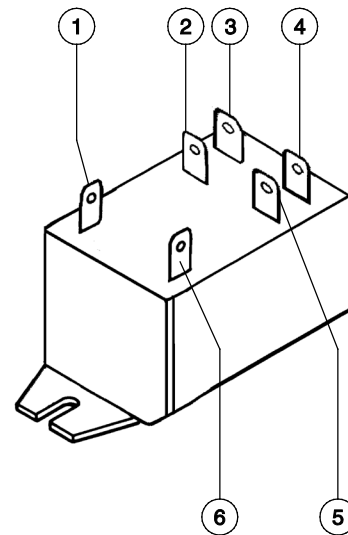

- 1 terminal no. 1
- 2 terminal no. 8
- 3 terminal no. 6
- 4 terminal no. 2
- 5 terminal no. 4
- 6 terminal no. 0

Test	Desired result
terminal 0 to 1	80 to 85 Ω
all other terminal combinations	no continuity (infinite Ω)

Hydraulic Power Unit

3-1

Hydraulic Power Unit - AC Models (to SN AWP03-27389 and IWP03-5150)

Index No.	Description	Function
1	115-230V AC electric motor	Single phase - 2850/3450 rpm, 50/60 Hz
2	Capacitor	Motor start circuit
3	Relief valve	Lift relief
4	Solenoid operated N.O. dump valve	Diverts pump output back to tank during motor start up
5	10V DC coil	Activates N.O. dump valve
6	Hydraulic tank	3 quarts / 2.8 liters
7	Drain plug	Drains hydraulic tank
8	Sight gauge	Hydraulic fluid level
9	Breather cap	Hydraulic tank vent/filler
10	Suction strainer	Filters hydraulic fluid
11	O-ring	Seals tank
12	Pump	0.5 to 0.6 gallons per minute at 2000 psi / 1.89 to 2.27 liters per minute at 138 bar
13	Check valve	Pump output
14	Motor seal	Seals motor from contaminants
15	Motor bearing	Aligns motor shaft into pump

Hydraulic Power Unit

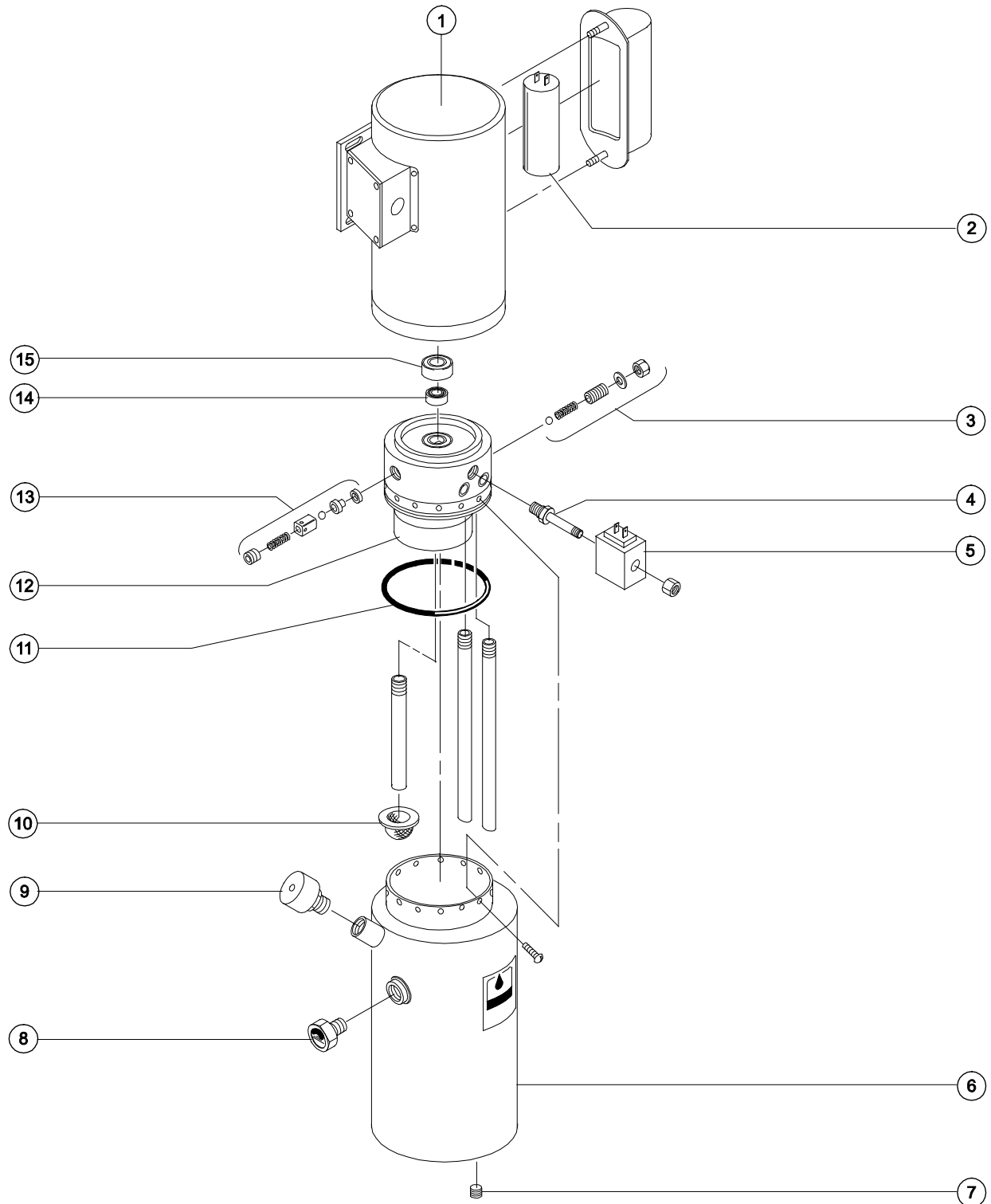

Hydraulic Power Unit

3-2

Hydraulic Power Unit - AC Models (from SN AWP03-27390 to AWP08-60145)

Index No.	Description	Function
1	115-230V AC electric motor	Single phase - 2850/3450 rpm, 50/60 Hz
2	Capacitor	Motor start circuit
3	Motor bearing	Aligns motor shaft into pump
4	Motor seal	Seals motor from contaminants
5	Relief valve	Lift relief
6	Pump	0.5 to 0.6 gallons per minute at 2000 psi / 1.89 to 2.27 liters per minute at 138 bar
7	Solenoid operated N.O. dump valve	Diverts pump output back to tank during motor start up
8	10V DC coil	Activates N.O. dump valve
9	O-ring	Seals tank
10	Return tube	Returns fluid to tank
11	Hydraulic tank	3 quarts / 2.8 liters
12	Drain plug	Drains hydraulic tank
13	Breather cap	Hydraulic tank vent/filler
14	Suction strainer	Filters hydraulic fluid
15	Suction tube	Sends fluid to pump
16	Check valve	Pump output

Hydraulic Power Unit

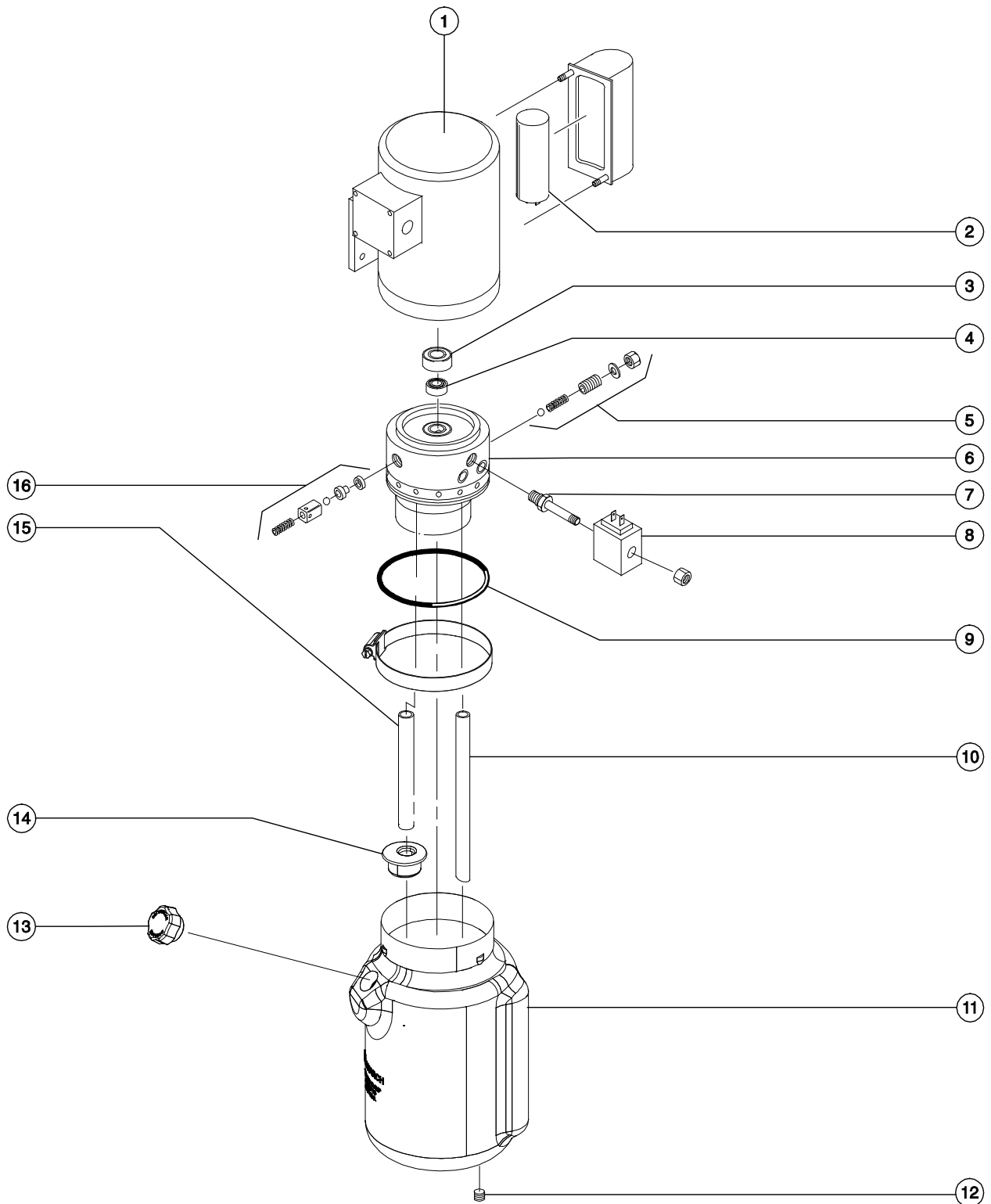

Hydraulic Power Unit

3-3

Hydraulic Power Unit - DC Models (to SN AWP03-27401 and IWP03-5122)

Index No.	Description	Function
1	12V DC electric motor	12V DC standard duty 1 terminal 180 A at 2650 psi / 183 bar
2	Motor starter solenoid	Power supply to electric motor
3	Relief valve	Lift relief
4	Solenoid operated N.O. dump valve	Diverts pump output back to tank during motor start up
5	10V DC coil	Activates N.O. dump valve
6	Hydraulic tank	3 quarts / 2.8 liters
7	Drain plug	Drains hydraulic tank
8	Sight gauge	Hydraulic fluid level
9	Breather cap	Hydraulic tank vent/filler
10	Suction strainer	Filters hydraulic fluid
11	O-ring	Seals tank
12	Pump	0.7 to 1 gpm at 2000 psi / 2.6 to 3.76 L/min at 138 bar
13	Check valve	Pump output
14	Motor seal	Seals motor from contaminants
15	Motor bearing	Aligns motor shaft into pump

Hydraulic Power Unit

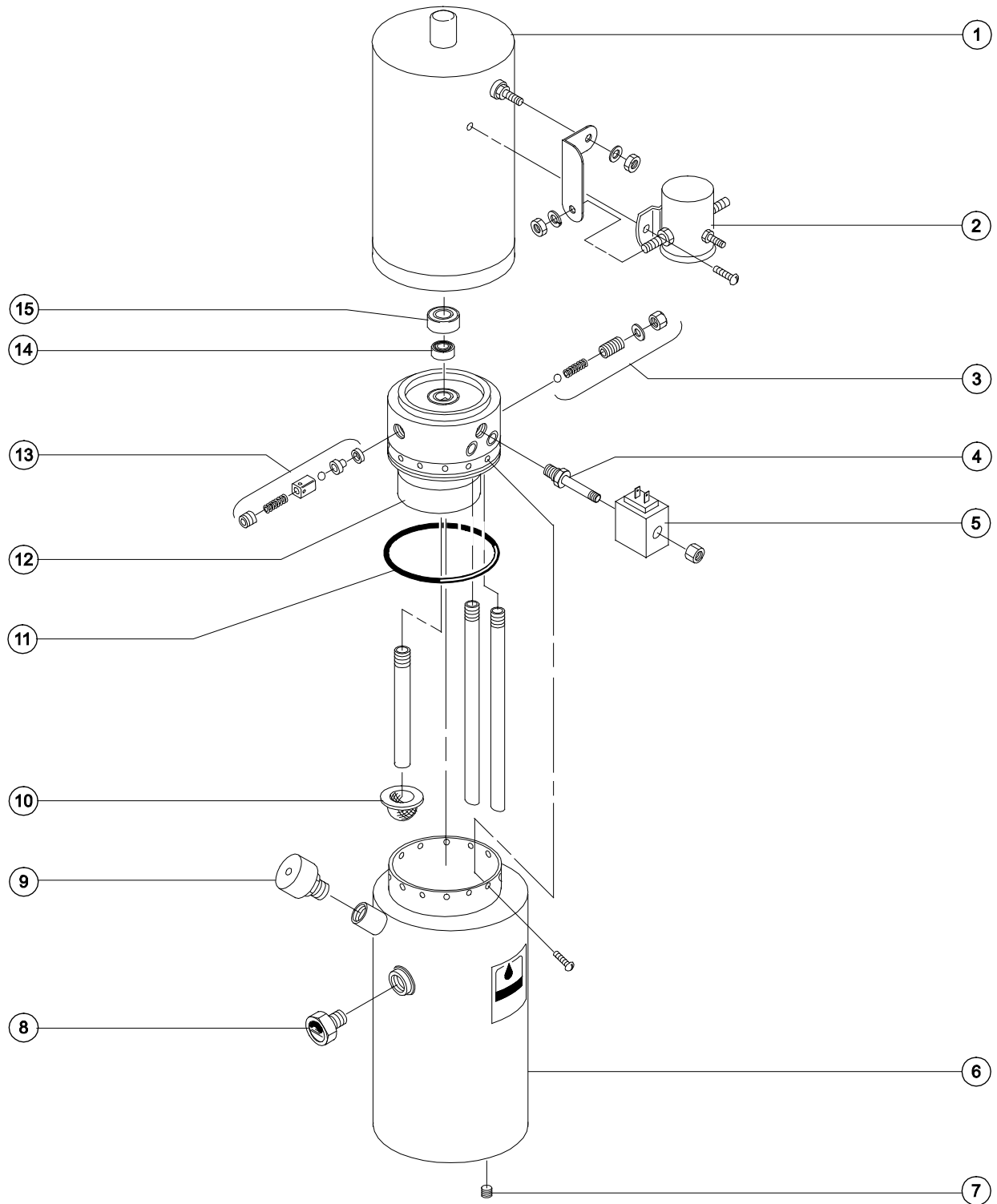

Hydraulic Power Unit

3-4

Hydraulic Power Unit Components - Air Powered Models (to SN AWP04-27778)

Index No.	Description	Function
1	Air motor	100 psi / 6.9 bar @ 80 cfm / 37760 cc/sec
2	Exhaust Muffler	Controls sound emissions
3	Relief valve	Relief valve
4	Valve N.O. Air Pilot	Diverts pump output back to tank during motor start up
5	O-ring	Seals tank
6	Hydraulic tank	3 quarts / 2.8 liters
7	Drain plug	Drains hydraulic tank
8	Sight gauge	Hydraulic fluid level
9	Tee fitting (models with Narrow or Rough Terrain Base Option)	Tank vent adaptor
10	Plug fitting (models with Narrow or Rough Terrain Base Option)	Plug
11	Suction strainer	Filters hydraulic fluid
12	Breather cap (from SN 3897-4545)	Hydraulic tank vent/filler
13	Breather cap (to SN 3897-4544)	Hydraulic tank vent/filler
14	Check valve	Pump output
15	Pump	0.7 to 1 gpm at 2000 psi / 2.6 to 3.76 L/min at 138 bar
16	Pump/Motor Adaptor Housing	Protects coupling components
17	Pump adaptor	Connects pump to spider coupler
18	Spider coupler	Connects motor to pump
19	Motor adaptor	Connects motor to spider coupler

Hydraulic Power Unit

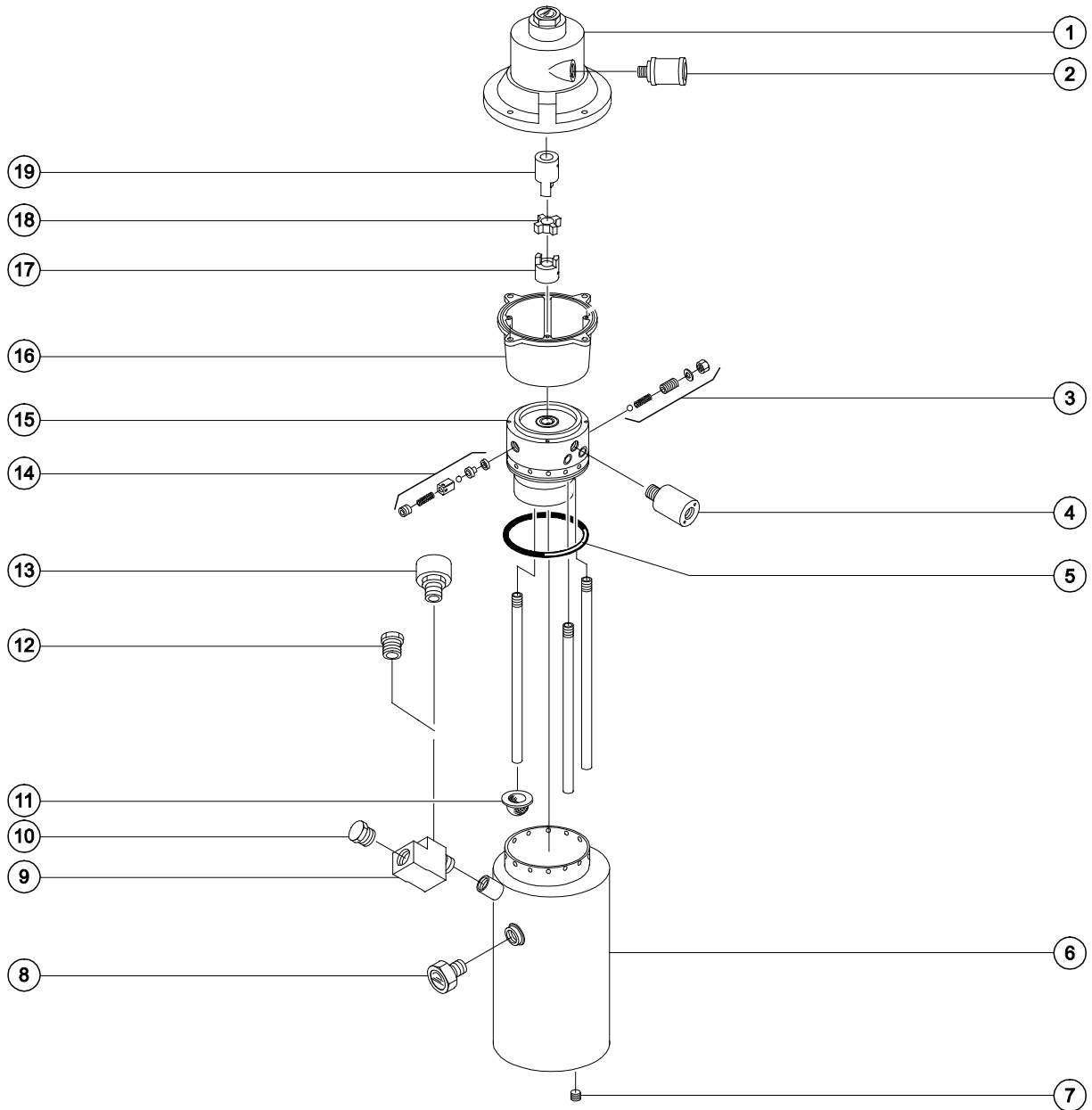

Hydraulic Power Unit

3-5 Hydraulic Power Unit

How to Remove the Hydraulic Power Unit - AC Models

- 1 Fully lower the platform.
- 2 Turn the key switch off and disconnect the power supply.
- 3 **IWPS models:** Pull the base lowering handle to fully lower the base.
- 4 Remove the power unit cover.
- 5 Tag, disconnect and plug the hydraulic hoses. Cap the fittings on the power unit.

▲ WARNING Bodily injury hazard. Spraying hydraulic oil can penetrate and burn skin. Loosen hydraulic connections very slowly to allow the oil pressure to dissipate gradually. Do not allow oil to squirt or spray.

- 6 Tag and disconnect the electrical wiring from the valve coil.

- 7 Remove the cover from the junction box on the motor. Tag and disconnect the electrical wiring in the junction box. Loosen the squeeze connector on the junction box and pull the wiring out through the squeeze connector.

DC models: Tag and disconnect the electrical wiring from the motor start solenoid.

Air models: Tag and disconnect the pneumatic hoses from the power unit.

- 8 Support the hydraulic power unit with a lifting device.
- 9 Remove the power unit mounting fasteners, then remove the power unit from the machine.

▲ WARNING Crushing hazard. The power unit will fall unless it is properly supported.

Note: If a new power unit is installed, the pressure relief valve must be properly adjusted. See 3-6, *How to Adjust the Pressure Relief Valve*.

Hydraulic Power Unit

How to Remove the Hydraulic Power Unit - DC Models

- 1 Fully lower the platform.
- 2 Turn the key switch off and disconnect the power supply.
- 3 **IWPS models:** Pull the base lowering handle to fully lower the base.
- 4 Remove the power unit cover.
- 5 Tag, disconnect and plug the hydraulic hoses. Cap the fittings on the power unit.

⚠ WARNING Bodily injury hazard. Spraying hydraulic oil can penetrate and burn skin. Loosen hydraulic connections very slowly to allow the oil pressure to dissipate gradually. Do not allow oil to squirt or spray.

- 6 Tag and disconnect the electrical wiring from the valve coil.
- 7 Tag and disconnect the electrical wiring from the motor start solenoid.
- 8 Support the hydraulic power unit with a lifting device.
- 9 Loosen the power unit mounting plate fasteners. Do not remove them.
- 10 Rotate the mounting plate away from the mast to access the power unit mounting fasteners.
- 11 Remove the power unit mounting fasteners, then remove the power unit from the machine.

⚠ WARNING Crushing hazard. The power unit will fall unless it is properly supported.

Note: If a new power unit is installed, the pressure relief valve must be properly adjusted. See 3-6, *How to Adjust the Pressure Relief Valve*.

How to Remove the Hydraulic Power Unit - Air Models

- 1 Fully lower the platform.
- 2 Turn the key switch off and disconnect the power supply.
- 3 Tag, disconnect and plug the hydraulic hoses. Cap the fittings on the power unit.

⚠ WARNING Bodily injury hazard. Spraying hydraulic oil can penetrate and burn skin. Loosen hydraulic connections very slowly to allow the oil pressure to dissipate gradually. Do not allow oil to squirt or spray.

- 4 Support the hydraulic power unit with a lifting device.
- 5 Loosen the power unit mounting plate fasteners. Do not remove them.
- 6 Rotate the mounting plate away from the mast to access the power unit mounting fasteners.
- 7 Remove the power unit mounting fasteners, then remove the power unit from the machine.

⚠ WARNING Crushing hazard. The power unit will fall unless it is properly supported.

Note: If a new power unit is installed, the pressure relief valve must be properly adjusted. See 3-6, *How to Adjust the Pressure Relief Valve*.

Hydraulic Power Unit

3-6 Hydraulic Pump

How to Remove the Hydraulic Pump

Note: When removing a hose assembly or fitting, the O-ring (if equipped) on the fitting and/or hose end must be replaced. All connections must be torqued to specification during installation. Refer to Specifications, *Hydraulic Hose and Fitting Torque Specifications*.

- 1 Fully lower the platform.
- 2 Turn the key switch off and disconnect the power supply.
- 3 **IWPS models:** Pull the base lowering handle to fully lower the base.
- 4 Remove the power unit cover.
- 5 Remove the power unit. See 3-4, *How to Remove the Power Unit*.
- 6 Support the hydraulic tank with a lifting device.
- 7 Remove the mounting fasteners from the tank. Remove the tank from the power unit. Do not allow the hydraulic oil to spill.

Note: It may be necessary to tap the side of the tank with a soft rubber mallet to loosen it.

- 8 Remove the mounting fastener from the suction cover assembly on the pump. Then remove the suction cover.
- 9 Remove the mounting fasteners from the pump. Then remove the pump from the power unit.

Note: When installing the tank, be sure not to damage the o-ring.

3-7 Valve Adjustment

How to Adjust the Platform Lift Relief Valve

Note: Be sure the hydraulic oil level is between the FULL and ADD marks on the oil level indicator.

- 1 Remove the power unit cover.
- 2 Loosen the locknut on the relief valve located on the right side of the motor.
- 3 Follow the appropriate operator's manual to set up the machine for operation.
- 4 Place maximum rated load into the platform. Secure the load to the platform. Refer to Specifications, *Machine Specifications*.
- 5 Hold the relief valve screw and loosen the lock nut.
- 6 While activating the platform up function, turn the relief valve screw clockwise, just until the platform begins to raise.
- 7 Fully lower the platform.
- 8 Add additional weight to the platform that is equal to, but does not exceed 20% of the maximum rated load. Secure the additional weight. Refer to the machine serial plate.

Hydraulic Power Unit

- 9 Activate the platform up function.
- 10 The power unit should not be able to lift the platform. If the power unit lifts the platform, turn the relief valve counterclockwise until the platform does not lift. Repeat steps 11 and 12 until the lift relief valve is properly adjusted.
- 11 Hold the relief valve screw and tighten the lock nut. Be sure the relief valve screw does not turn.
- 12 Remove the weight from the platform.
- 13 Bleed the hydraulic system by raising the platform to full height. If the pump cavitates or the platform fails to reach full height, add hydraulic oil until the pump is functioning correctly. Do not overfill the hydraulic tank.

NOTICE Component damage hazard. Do not continue to operate the machine if the hydraulic pump is cavitating.

- 14 Install the breather cap and the power unit cover.

3-8 How to Test the Motor Start Solenoid - DC Models

⚠ WARNING Electrocuting/burn hazard. Contact with electrically charged circuits could result in death or serious injury. Remove all rings, watches and other jewelry.

⚠ WARNING Electrocuting hazard. Disconnect the ground cable from the battery before performing this procedure.

- 1 Tag and disconnect the electrical wiring from the motor start solenoid.
- 2 Connect the leads from an ohmmeter to the following terminal combinations and check the continuity/resistance.

Test	Desired result
Small post to ground	13 to 17Ω
2 large posts	no continuity (infinite Ω)

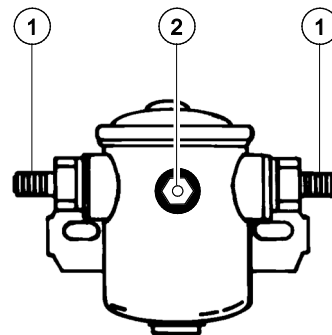

- 1 high amp power terminal (large posts)
- 2 solenoid coil terminal (small post)

- 3 Connect 12V DC to the small post and a ground wire to the case of the solenoid, then test the following terminal combinations.

Test	Desired result
2 large posts	continuity (zero Ω)

Power Pack

4-1 Power Pack

How to Change a Power Pack

- 1 Fully lower the platform.
- 2 Turn the key switch off and disconnect the power supply.
IWP models: Pull the base lowering handle to fully lower the base.
- 3 Remove the power unit cover.
- 4 **AC and DC models:** Separate both control cable quick disconnect couplers from the ground control box.
Air models: Disconnect the air lines from the air valve container, filter regulator and air lubricator.
- 5 **AC and DC models:** Separate the battery quick disconnects.
- 6 **DC models:** Disconnect the battery cables from the motor start solenoid.
- 7 **AWPS models with Narrow Base or Rough Terrain Base:** Remove the loading wheels.

- 8 Remove the breather cap from the hydraulic power unit and install a pipe plug in the filler hole.
- 9 Tag, disconnect and plug the hydraulic hoses from the power unit.

▲ WARNING Bodily injury hazard. Spraying hydraulic oil can penetrate and burn skin. Loosen hydraulic connections very slowly to allow the oil pressure to dissipate gradually. Do not allow oil to squirt or spray.

- 10 Support the power pack and remove the power pack mounting bolts.

▲ WARNING Crushing hazard. The power pack will fall if not properly supported when removed from the machine.

- 11 Remove the power pack.

Installation

▲ DANGER Tip-over hazard. On Narrow Base and Rough Terrain Base models, the counterweights must be installed on the new power pack.

NOTICE Component damage hazard. Do not overtighten the hydraulic fittings.

Note: Do not install the motor cover until the relief valve adjustment is complete. Refer to Repair Procedure, *How to adjust the Pressure Relief Valve*.

Mast Components

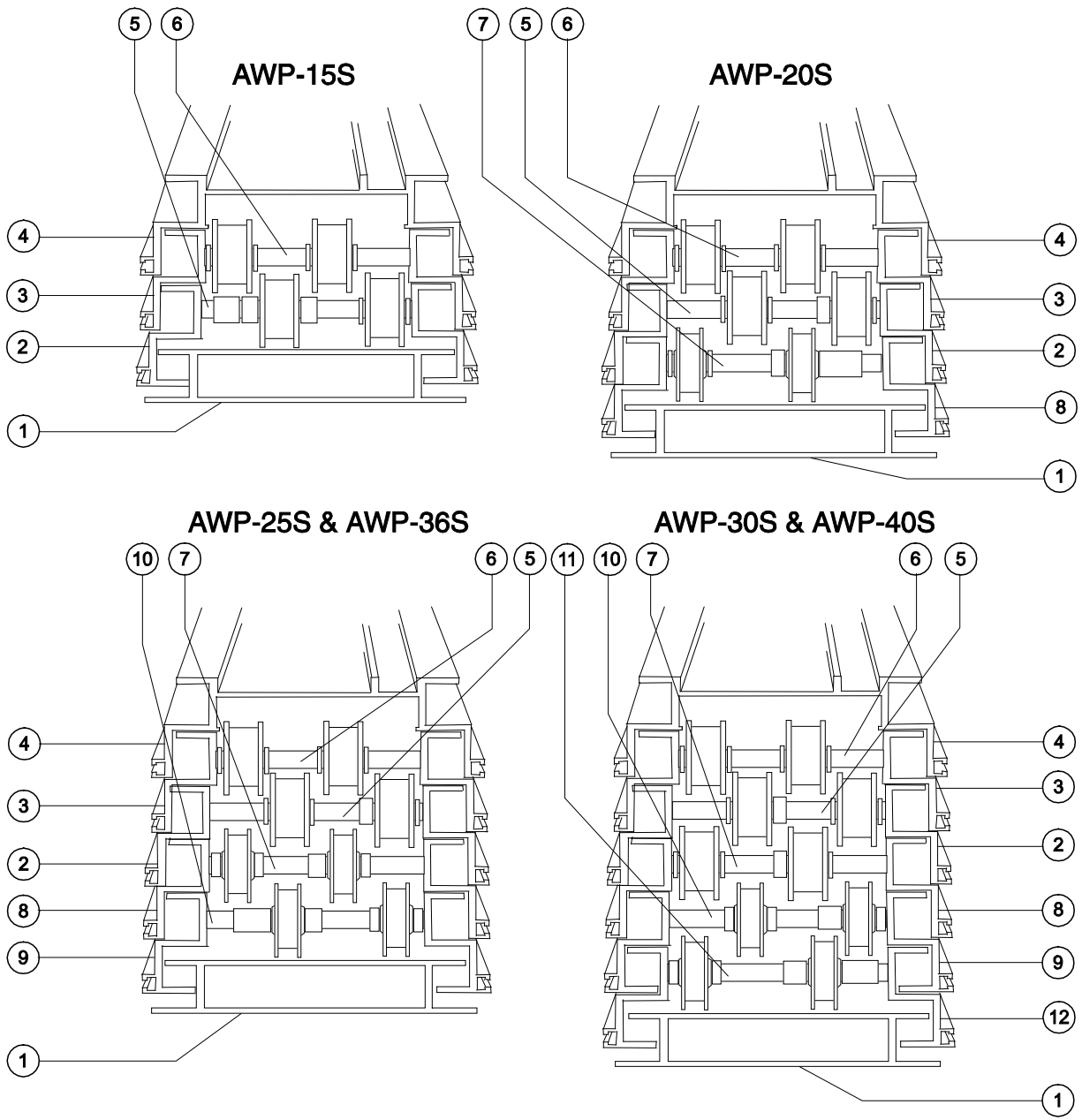

- 1 carriage
- 2 number 3 column
- 3 number 2 column
- 4 number 1 column
- 5 number 3 column idler wheel assembly
- 6 number 2 column idler wheel assembly

- 7 number 4 column idler wheel assembly
- 8 number 4 column
- 9 number 5 column
- 10 number 5 column idler wheel assembly
- 11 number 6 column idler wheel assembly
- 12 number 6 column



Mast Components

5-1 Lift Cylinder

How to Remove the Lift Cylinder

▲ WARNING Bodily injury hazard. This procedure requires specific repair skills, lifting equipment and a suitable workshop. Attempting this procedure without these skills and tools could result in death or serious injury and significant component damage. Dealer service is strongly recommended.

Note: When removing a hose assembly or fitting, the O-ring (if equipped) on the fitting and/or hose end must be replaced. All connections must be torqued to specification during installation. Refer to Specifications, *Hydraulic Hose and Fitting Torque Specifications*.

- 1 Fully lower the platform.
- 2 Turn the key switch to the off position.
AWPS models: Remove the outriggers from the outrigger storage socket.
DC models: Remove the battery pack.
- 3 Remove the breather cap from the hydraulic power unit and install a pipe plug in the filler hole.
- 4 Attach an overhead crane to the lifting eye at the top of the mast.
- 5 Place a saw horse in front of the machine where the top of the mast will rest.

- 6 Lift the machine off the ground and then while lowering it, guide it over onto the saw horse. Be sure the saw horse is of ample capacity.

▲ CAUTION Crushing hazard. The machine will fall unless it is properly supported by the saw horse.

- 7 Remove the socket head retaining bolt from the clevis block on the lift cylinder rod end.

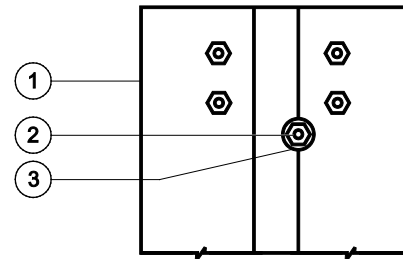

- 1 top of no. 1 column
- 2 retaining fastener
- 3 clevis block

- 8 Tag, disconnect and plug the lift cylinder hydraulic hoses. Cap the fittings on the lift cylinder.

▲ WARNING Bodily injury hazard. Spraying hydraulic oil can penetrate and burn skin. Loosen hydraulic connections very slowly to allow the oil pressure to dissipate gradually. Do not allow oil to squirt or spray.

- 9 Remove the cylinder mounting fasteners from the barrel end of the cylinder.

Mast Components

- 10 Loosen the cylinder mounting bracket fasteners

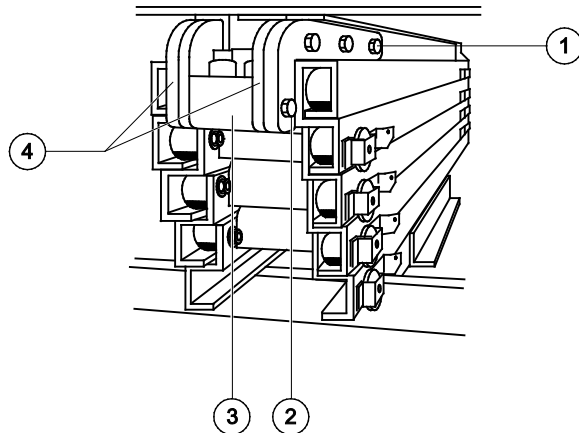

- 1 Bracket mounting fasteners
- 2 Cylinder mounting fasteners
- 3 Hydraulic cylinder
- 4 Cylinder mounting plate

- 11 Support the cylinder and carefully slide it out of the bottom of the mast.

CAUTION Crushing hazard. The lift cylinder will fall unless it is properly supported.

5-2 Mast Assembly

How to Remove the Mast Assembly - AWPS Models

WARNING Bodily injury hazard. This procedure requires specific repair skills, lifting equipment and a suitable workshop. Attempting this procedure without these skills and tools could result in death or serious injury and significant component damage. Dealer service is strongly recommended.

- 1 Fully lower the platform.
- 2 Turn the key switch off and remove the key.
- 3 Remove the platform. Refer to Repair Procedure, *How to Remove an Aluminum Platform*.
- 4 Remove the power pack. Refer to Repair Procedure, *How to Change a Power Pack*.
- 5 **AWP-36S and 40S models:** Remove the tilt-back frame. Refer to Repair Procedure, *How to Remove the Tilt-back Frame*.
- 6 Attach an overhead crane to the lifting eye at the top of the mast.
- 7 Place a saw horse in front of the machine where the top of the mast will rest.

Mast Components

- 8 Lift the machine off the ground and then while lowering it, guide it over onto the saw horse. Be sure the saw horse is of ample capacity.

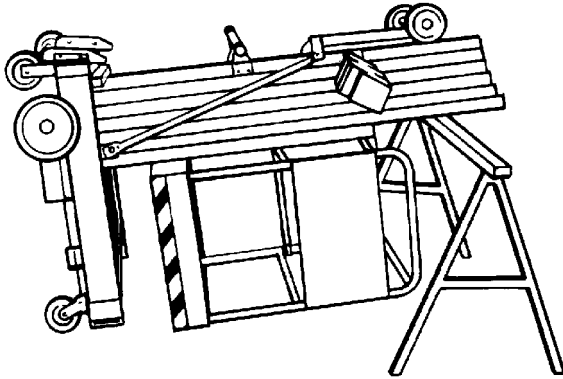

CAUTION Crushing hazard. The machine will fall unless it is properly supported by the saw horse.

- 9 Attach the overhead crane to the base.
 10 Lift the base until the mast is level then place a second saw horse under the mast near the base. Lower the mast onto the saw horse.
 11 Remove the cover on the rear of the base.

- 12 Tag, disconnect and plug the lift cylinder hydraulic hoses. Remove the flow control valve from the cylinder. Cap the cylinder ports

WARNING Bodily injury hazard. Spraying hydraulic oil can penetrate and burn skin. Loosen hydraulic connections very slowly to allow the oil pressure to dissipate gradually. Do not allow oil to squirt or spray.

- 13 Remove the mast brace mounting bracket fasteners.
 14 Remove the four mast mounting fasteners. Push the fasteners toward the mast for clearance during mast removal.
 15 **AWP-15S, 20S, 25S, and 30S models:** Remove the power cable brackets from the side of the mast.
AWP-36S and 40S models: Remove the rubber grommet from the access hole in the mast stiffener. Carefully pull the electrical cables and hydraulic hoses down and out through the bottom of the mast.
 16 Attach the overhead crane to the base.
 17 Carefully lift and remove the base from the mast. Do not damage the lift cylinder hydraulic fittings when removing the base

CAUTION Crushing hazard. The base will fall unless it is properly supported when it is removed from the mast.

Mast Components

How to Remove the Mast Assembly - IWPS Models

⚠ WARNING Bodily injury hazard. This procedure requires specific repair skills, lifting equipment and a suitable workshop. Attempting this procedure without these skills and tools could result in death or serious injury and significant component damage. Dealer service is strongly recommended.

- 1 Fully lower the platform.
- 2 Turn the key switch off and remove the key.
- 3 Pull the base lowering handle to fully lower the base.
- 4 Remove the platform. Refer to Repair Procedure, *How to Remove an Aluminum Platform*.
- 5 Remove the power pack. Refer to Repair Procedure, *How to Change a Power Pack*.
- 6 Tag, disconnect and plug the lift cylinder hydraulic hoses. Remove the flow control valve from the cylinder. Cap the cylinder ports

⚠ WARNING Bodily injury hazard. Spraying hydraulic oil can penetrate and burn skin. Loosen hydraulic connections very slowly to allow the oil pressure to dissipate gradually. Do not allow oil to squirt or spray.

- 7 Remove the level sensor assembly mounting fasteners.
- 8 Remove the base lowering cable mounting fasteners from the side of the mast.
- 9 Disconnect the control cable tension spring.

- 10 Attach an overhead crane to the lifting eye at the top of the mast.
- 11 Remove the four mast mounting fasteners. Push the fasteners toward the mast for clearance during mast removal.
- 12 Carefully lift the mast out of the base

⚠ CAUTION Crushing hazard. The mast will fall unless it is properly supported when it is removed from the base.

- 13 Place two saw horses under the mast.
- 14 Lower the mast onto the saw horses with the carriage facing down.

Mast Components

How to Disassemble the Mast

⚠ WARNING Bodily injury hazard. This procedure requires specific repair skills, lifting equipment and a suitable workshop. Attempting this procedure without these skills and tools could result in death or serious injury and significant component damage. Dealer service is strongly recommended.

- 1 Remove the mast. Refer to Repair Procedure, *How to Remove the Mast Assembly*.
- 2 Remove the cylinder mounting fasteners from the barrel end of the cylinder.
- 3 Remove the socket head retaining bolt from the clevis block on the lift cylinder rod end.

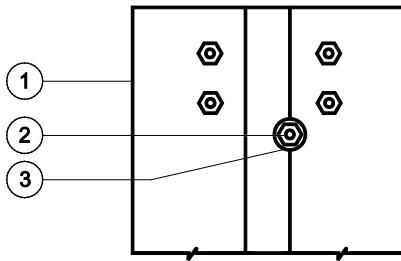

- 1 top of no. 1 column
- 2 retaining fastener
- 3 clevis block

- 4 Support the cylinder and carefully slide it out of the bottom of the mast.
- 5 Carefully rotate the mast until the carriage is facing up.
- 6 Remove the mast covers.
- 7 Remove the cover from the platform control box. Remove the control box mounting fasteners.
- 8 Remove the control box and control cable and set them aside.
- 9 **IWPS models:** Remove the base lowering cable bracket from the mast.

- 10 Remove the adjustment nuts from all of the sequencing cables.
- 11 Slide the carriage towards the top of the mast assembly enough to remove the tension on the lifting chain.
- 12 Slide the column below the carriage toward the top of the mast about 6 inches / 15.2 cm to access the idler wheel mounting fasteners.
- 13 Hold the idler wheel axle from turning by placing a screwdriver in the hole of the axle. Remove the axle mounting fasteners and remove the idler wheel assembly.

NOTICE Be sure to label the location and orientation of each idler wheel assembly.

- 14 Remove the adjustment nuts from the chain tension rocker on the carriage.
- 15 Slide the carriage out the bottom of the mast assembly.
- 16 Lay the chains out on the floor at the top of the mast. Do not allow the chains to become twisted or dirty.
- 17 Remove the adjustment nuts from the chain tension rocker on the column.
- 18 Slide the column out the bottom of the mast.
- 19 Push the next column toward the top of the mast to access the idler wheel assembly mounting fasteners.
- 20 Hold the idler wheel axle from turning by placing a screwdriver in the hole of the axle. Remove the axle mounting fasteners, and remove the idler wheel assembly.
- 21 Remove the adjustment nuts from the chain tension rocker on the column.
- 22 Slide the column out the bottom of the mast.
- 23 Repeat steps 19 through 22 for each remaining column.

Note: If the chains are removed, mark the location and label each chain before removal.

Mast Components

How to Assemble the Mast

⚠ WARNING Bodily injury hazard. This procedure requires specific repair skills, lifting equipment and a suitable workshop. Attempting this procedure without these skills and tools could result in death or serious injury and significant component damage. Dealer service is strongly recommended.

- 1 Thoroughly clean all columns.
- 2 Secure the number 1 column to the saw horses and lay the chains out on the floor at the top. Do not allow the chains to become twisted or dirty.
- 3 Apply a generous amount of Boe-lube wax (Genie part number 90337) to the inside and outside channels of each column.
- 4 Slide the number 2 column into the number 1 column.
- 5 Lay the number 2 column chains on the floor. Do not allow the chains to become twisted or dirty.
- 6 Lay the number 1 column chains inside the number 2 column.
- 7 Slide the number 3 column into the number 2 column.
- 8 When the number 3 column is almost all the way in, guide the number 1 column chains into the chain tension rocker on the number 3 column.
- 9 Install the adjustment nuts on the number 1 column chains. Tighten the adjustment nuts until the lifting chains have equal tension and the chain tension rocker is centered in the inspection hole in the column.
- 10 Lay the number 3 column chains on the floor. Do not allow the chains to become twisted or dirty.
- 11 Lay the number 2 column chains inside the number 3 column.
- 12 Follow steps 4 through 11 for each remaining column and the carriage.
- 13 After all the columns are assembled, the idler wheel assemblies can be installed.
- 14 Remove the tension from the lifting chains on the number 2 column by pushing the number 3 column towards the top of the mast.
- 15 Install the idler wheel assembly into the top of the number 2 column. Securely tighten the mounting fasteners. Do not over tighten.

Note: Confirm that all idler wheels rotate with no excessive side movement. Confirm that they do not rub on the inside of the column. Replace worn spacers if necessary. Refer to Maintenance Procedure, *Inspect the Mast Assembly for Wear*.

Specification

Side movement, Maximum	0.079 inch 2 cm
------------------------	--------------------

Mast Components

- 16 Repeat steps 14 and 15 for each remaining idler wheel assembly.
- 17 Confirm that all of the idler wheel axle mounting fasteners are flush with the column.

▲ CAUTION Component damage hazard. The roller wheels may be damaged if the idler wheel axle mounting fasteners are not flush with the column.

- 18 Install the mast assembly on the base.
- 19 Adjust the lifting chains. Refer to Repair Procedure, *How to Adjust the Lifting Chains*.

Note: **IWPS Models:** Adjust the base release cable. Refer to Repair Procedure, *How to Adjust the Base Release Cable*.

5-3 Glide Pads

How to Adjust the Glide Pads

- 1 Fully lower the platform.
- 2 Turn the key switch off and remove the key.
- 3 Locate the upper and lower glide pad adjustment bolts below each upper roller bolt on both sides of each column.
- 4 Hold the glide pad bolt and loosen the lock nut on all the glide pads.
- 5 Turn all the glide pad adjustment bolt clockwise until the glide pad makes contact with the column. Adjust the slide pads on both sides of all column mast. Be sure the sides of the columns are even to within 1/8 inch / 3.17 mm of each other.
- 6 Starting at the number 1 column, torque the upper and lower glide pad bolts to 12 in-lbs / 1.35 Nm. Hold the glide pad adjustment bolt and tighten the lock nut. Be sure the glide pad bolt does not turn.
- 7 Repeat step 5 for each remaining upper and lower glide pad on both sides of the mast. Start at the number 1 column and work toward the carriage.
- 8 Repeat step 5 for all of the upper and lower glide pads.

Note: Make sure glide pad bolts are adjusted evenly on each side to maintain squareness of the columns.

Mast Components

5-4 Lifting Chains

How to Adjust the Lifting Chains

- 1 Fully lower the machine and check if all the columns are adjusted correctly.
 - ⦿ Result: The top of each column is approximately 3/8 inch / 1.0cm higher than the previous column. The columns are adjusted properly.
 - ⊗ Result: Any column is more than 3/8 inch / 1.0cm higher than the previous column. The columns must be adjusted.

Note: The two columns closest to the base are not adjustable and should be approximately even across the top.

To adjust column chains:



- 2 Mark the column to be adjusted.
- 3 Raise the platform 6 feet / 2 m.
- 4 Turn the adjustment lock nuts evenly on both chain terminals clockwise to raise the column or counterclockwise to lower the column.
- 5 Fully lower the machine and confirm the alignment of the columns. Adjust if necessary.
- 6 Confirm that the chain terminals on each column have equal tension and the lock nuts are tight.

Mast Components

How to Inspect the Lifting Chains

Inspection	Procedure	Inspection Failure	Inspection Remedy
Wear	Count out 16 chain links and measure pin to pin centerline dimension with a steel measuring tape. Note: Measure a section of chain that moves over the idler wheels.	When the length of the 16 links (pin to pin) measure more than 8.25 inches / 21 cm for 1/2 inch / 12.7mm chain or 10.31 inches / 26.1 cm for 5/8 inch / 15.9 mm chain.	Replace both chains on that column. Replace entire chain. Do not repair just the affected portion of the chain.
Rust and Corrosion	Visually inspect the chains for rust and corrosion.	Evidence of rust or corrosion.	Remove chain and inspect for cracked plates (see inspection of cracked plates). If no cracks are found, lubricate chain with motor oil (SAE 40) and install chain.
	Visually inspect the chains for lubrication.	When external surfaces are not protected with a layer of oil.	Lubricate chain with motor oil (SAE 40W).
Tight Joints	Inspect chain link joints for easy movement.	Joints that do not flex freely or are binding.	If rust and corrosion is found, refer to Failure Remedy for rust and corrosion. If link plates or pins are bent or deformed, replace entire chain. Replace both chains on that column. Do not repair just the affected portion of the chain.

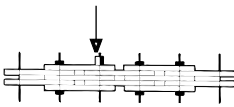
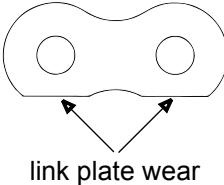
Mast Components

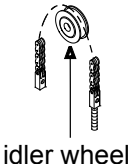
Inspection	Procedure	Inspection Failure	Inspection Remedy
Raised or Turned Pins	Visually inspect for raised pins.	Raised pins. 	Replace both chains on that column section. Do not repair just the affected portion of the chain.
	Visually inspect for turned pins by insuring all the flats on the "V" heads are aligned.	Misalignment of flats on all "V" heads.	Replace both chains on that column section. Do not repair just the affected portion of the chain.
Chain Side	Visually inspect for wear patterns on heads of link pins and outside link plates where they contact the idler wheel.	Wear on pin heads or noticeable wear in the profile of the outside link plate.	Replace both chains on that column section. Do not repair just the affected portion of the chain.
		 link plate wear	Check alignment of chain anchors and idler wheels.
Chain Anchors  chain anchors threaded rod	Visually inspect chain anchors.	Broken chain anchor fingers.	Replace chain anchor.
		Bent or damaged anchor.	Replace chain anchor.
		Twisted or misaligned chain anchor.	Re-align chain anchor to ensure even loading of chain.
		Threaded rod not visible in inspection hole.	Replace chain anchor and threaded rod.
Idler Wheels  idler wheel	Visually inspect chain idler wheels.	Idler wheels have badly worn flanges.	Replace idler wheel and check chain alignment.
		Idler wheels have grooves worn into chain contact surface.	Replace idler wheel.
Cracked Link Plates	Visually inspect chain link plates for cracks.	Cracks in any chain link plate.	Replace both chains on that column section. Replace entire chain. Do not repair just the affected portion of the chain.



Tilt-back Frame, AWP-36S and 40S Models

6-1 Tilt-back Frame

How to Remove the Tilt-back frame

- 1 Fully lower the platform.
- 2 Turn the key switch off and remove the key.
- 3 Maintain a firm grasp on the tilt-back frame and remove the retaining pin. Lower the tilt-back frame to the ground.
- 4 Remove the fasteners that mount the tilt-back frame hinges to the base.

Note: Note the amount of shims used between the hinges and the base.

- 5 Remove the frame from the machine.

How to Adjust the Loading Pivot or Stop Bracket

Note: Check for side-to-side movement of the pivot slider or stop bracket. They should have no side-to-side clearance and not be too tight to cause dragging or binding. Adjust if necessary.

- 1 Remove the tilt-back frame. Refer to Repair Procedure, *How to Remove the Tilt-back Frame*.
- 2 Remove the mounting fasteners from the tilt-back frame hinges.

- 3 Slide the pivot slider and the stop bracket out of the frame and add shims as necessary to obtain zero clearance and zero drag.

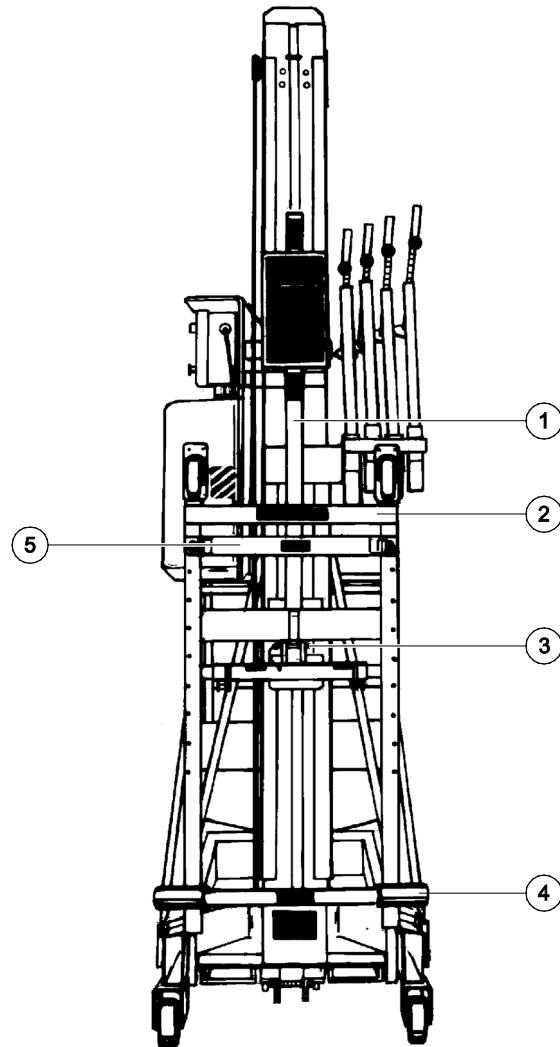

- 1 shock absorber assembly
- 2 tilt-back frame
- 3 shock absorber mounting bolt
- 4 loading pivot bar
- 5 loading stop bracket

Tilt-back Frame, AWP-36S and 40S Models

How to Disassemble the Shock Absorber

- 1 Fully lower the platform.
- 2 Turn the key switch off and remove the key.
- 3 Maintain a firm grasp on the tilt-back frame and remove the retaining pin. Lower the tilt-back frame to the ground.
- 4 Remove the fastener that mounts the shock absorber assembly to the frame.
- 5 Remove the shock absorber assembly from the frame and separate the lower tube from the assembly.
- 6 Pull the shock absorber out of the upper tube.
- 7 Remove the metric nut from each end of the shock absorber and remove the mounting blocks.

⚠ WARNING Bodily injury hazard. Contents of the shock absorber are under pressure. Use care during removal.

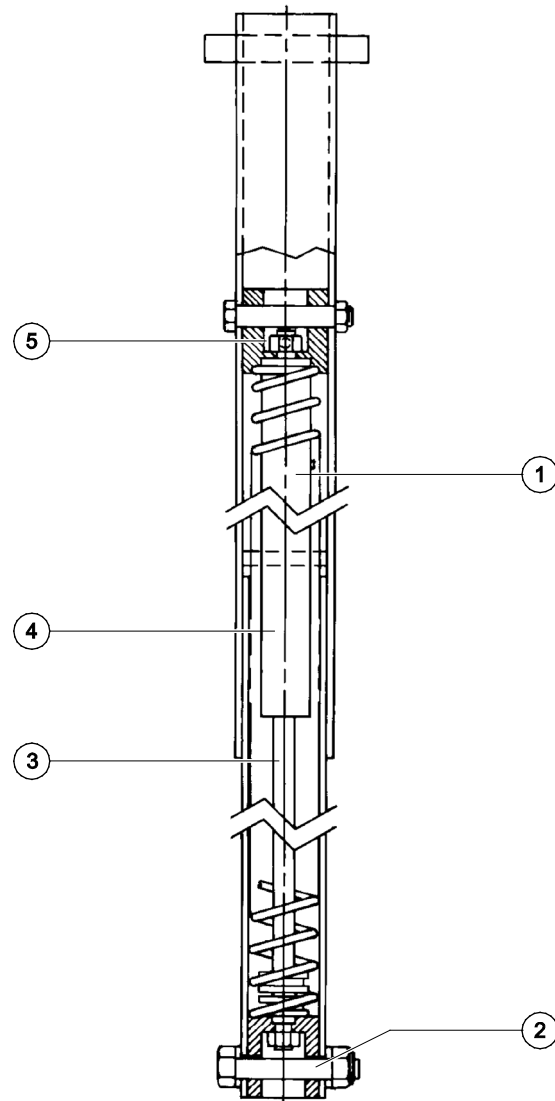

- 1 shock absorber
- 2 lower shock mounting block
- 3 lower tube
- 4 upper tube
- 5 upper shock mounting block

Platform

7-1 Platforms

How to Remove an Aluminum Platform

- 1 Place support blocks between the platform and base. Lower the platform onto the block.

⚠ WARNING Crushing hazard. Keep away from the lowering platform.

- 2 Remove the mounting fasteners from the platform.
- 3 Pull the platform away from the mast and remove it from the machine.

⚠ WARNING Bodily injury hazard. Safety decals are essential to safe machine operation. Failure to replace all safety and instructional decals could result in death or serious injury. If a platform must be replaced, be sure that all appropriate safety and instructional decals are applied to the new platform.

How to Install a Fiberglass Platform

- 1 Remove the aluminum platform. Refer to Repair Procedure, *How to Remove an Aluminum Platform*.
- 2 Support the platform with a lifting device, place the platform against the mounting angles.
- 3 Install the mounting fastener.

⚠ WARNING Bodily injury hazard. Safety decals are essential to safe machine operation. Failure to replace all safety and instructional decals could result in death or serious injury. If a platform must be replaced, be sure that all appropriate safety and instructional decals are applied to the new platform.

Platform

7-2 Platform Control Box

How to Test the Contacts

- 1 Fully lower the platform.
- 2 Turn the key switch off and disconnect the power supply.
- 3 Remove the platform control box cover fasteners and open the control box.
- 4 Note the markings on the contact to be tested. N.O. designates the contact as normally open. N.C. designates the contact as normally closed.
- 5 Connect a continuity tester to the exposed screw terminal.
 - ⦿ Result: Normally open contacts should read no continuity. Normally closed contacts should read continuity.
- 6 Push the small triangular button on the top of the contactor.
 - ⦿ Result: Normally open contactor should read continuity. Normally closed contacts should read no continuity.

How to Test Power to Platform GFCI Outlet

- 1 Fully lower the platform.
- 2 Turn the key switch off and remove the key.
- 3 **AC and DC models:** Be sure the AC power supply is properly connected.
- 4 Connect a volt meter or a small electric powered tool to the platform GFCI receptacle.
- 5 Confirm the voltage or test the electric powered tools operation.
 - ⦿ Result: The voltage should be 115V AC nominal or the electric powered tool should operate normally.
- 6 Push the black TEST button on the GFCI receptacle.
 - ⦿ Result: The voltage should be 0V or the electric powered tool should not operate.
- 7 Push the red RESET button on the GFCI receptacle.
 - ⦿ Result: The voltage should be 115V AC nominal or the hand tool should operate normally.

Platform

7-3 Platform Outreach Chain

How to Adjust the Platform Outreach Chain, IWP-20S Models

- 1 Fully lower the platform.
 - 2 Turn the key switch off and remove the key.
 - 3 Fully extend the platform outreach. Lock the handle in position.
 - 4 Place a block of wood between the carriage and the platform outreach to prevent the outreach from collapsing when the fasteners are loosened.
- ⚠ WARNING** Crushing hazard. The platform outreach will collapse if it is not properly supported when the fasteners are loosened.
- 5 Locate the lower sprocket housing fasteners.
 - 6 Loosen but do not remove both sprocket housing fasteners.
 - 7 Push downward on the sprocket housing to remove excess slack from the chain.
 - 8 Tighten the sprocket housing fasteners.
 - 9 Confirm proper chain adjustment. Refer to Maintenance Procedure, *Check the Chain Adjustment*.

How to replace the Outreach Chain, IWP-20S Models

- 1 Fully lower the platform.
 - 2 Turn the key switch off and remove the key.
 - 3 Pull the base lowering handle to fully lower the base.
 - 4 Remove the platform.. Refer to Repair Procedure, *How to Remove an Aluminum Platform*.
 - 5 Remove the platform control box cover fasteners and open the control box.
 - 6 Remove the platform control box mounting fasteners. Remove the platform control box and set it aside.
 - 7 Extend the outreach approximately 14 inches /36 cm. Lock the handle in position.
 - 8 Attach an overhead crane to the center brace pivot pin on the outreach assembly.
 - 9 Remove the assembly mounting fastener.
- ⚠ WARNING** Crushing hazard. When the mounting fasteners are removed, the platform outreach will become unbalanced and may fall if it is not properly supported.
- 10 Lay the outreach assembly onto a workbench or table of ample capacity. Be sure the chain is facing up.
 - 11 Place a block of wood under the inner frame assembly for support while removing the chain.

- ⚠ WARNING** Crushing hazard. The platform outreach will collapse if it is not properly supported when the chain is removed.

Platform

- 12 Remove the lower sprocket housing mounting fasteners. Do not allow the chain to become twisted.
 - 13 Remove the upper sprocket housing mounting fasteners. Do not allow the chain to become twisted.
 - 14 Remove the fasteners from the outreach locking bracket.
 - 15 Slide the platform mount off the inner frame extension arms and set it aside.
 - 16 Locate the two allen head screws in the platform mount slide pad.
 - 17 Remove the roller from the same side of the slide pad.
 - 18 Remove the two allen head screws.
 - 19 Remove the master link from the chain.
 - 20 Pull the chain out of the slide pad and both sprocket housings.
 - 21 Install the new chain through the slidepad.
 - 22 Push the chain through the slide pad until approximately 2 inches / 5 cm of the chain is extended past the slide pad.
 - 23 Install the two allen head screws. Install the roller wheel.
 - 24 Thread the chain through the upper sprocket housing over the sprocket, then back through the housing.
 - 25 Thread the chain through the lower sprocket housing over the sprocket, then back through the housing. Don't allow the chain to become twisted.
 - 26 Do not re-use the old master link. Install a new master link.
 - 27 Slide the platform mount onto the extension arms.
 - 28 Install the outreach locking bracket on the platform mount.
 - 29 Install the upper sprocket housing to the platform mount.
- Note: When fasteners are installed, be sure the center bolt is in between the two chains inside the housing.
- 30 Pull the slack out of the chain by pushing down on the lower sprocket housing.
 - 31 Install the lower sprocket housing fasteners.
 - 32 Adjust the chain. Refer to Repair Procedure, *How to Adjust the Platform Outreach Chain*.
 - 33 Install the outreach assembly onto the carriage.

Schematics



Observe and Obey:

- ☑ Troubleshooting and repair procedures shall be completed by a person trained and qualified on the repair of this machine
- ☑ Immediately tag and remove from service a damaged or malfunctioning machine.
- ☑ Repair any machine damage or malfunction before operating the machine.

Before Troubleshooting:

- ☑ Read, understand and obey the safety rules and operating instructions in the appropriate operator's manual on your machine.
- ☑ Be sure that all necessary tools and test equipment are available and ready for use.

About This Section

There are two groups of schematics in this section.

Electrical Schematics

⚠ WARNING

Electrocution/burn hazard. Contact with electrically charged circuits could result in death or serious injury. Remove all rings, watches and other jewelry.

Hydraulic Schematics

⚠ WARNING

Bodily injury hazard. Spraying hydraulic oil can penetrate and burn skin. Loosen hydraulic connections very slowly to allow the oil pressure to dissipate gradually. Do not allow oil to squirt or spray.

Electrical Component and Wire Color Legends











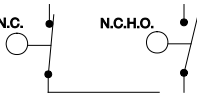

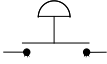
Item	Description
B	Battery
B2	12V DC
B4	8 AA batteries
CB	Circuit Breaker
CB4	15 AMP – 120V AC / 8 AMP – 240V AC
CB9	6 AMP – 120V AC / 3 AMP – 240V AC
CR96	Power wheel (IWP)
D5	Power supply AC
EN	Enclosure
EN1	Platform control box
EN2	Ground control box
EN3	Remote box (ce option)
EN4	Power to platform GFCI receptacle
EN5	Power unit – 110V AC
EN6	Power unit – 220V AC
F	Fuse
F1	15 Amp
F11	175 Amp
FB2	Warning light
GND	Ground
H4	Descent alarm
KS1	Key switch ground/platform
LS1	Limit switch - platform extension (IWP option)
L	Led or light
L5	Power indicator (ground)
L6	Low battery indicator for auxiliary (ground)
L7	Low battery indicator – main (ground)
L12	Outrigger – front left (ground)
L13	Outrigger – front right (ground)
L14	Outrigger – rear left (ground)

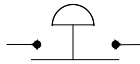
Item	Description
L	Led or light cont.
L15	Outrigger – rear right (ground)
L66	Level sensor interlock (IWP)
L67	Footpad interlock (IWP)
M5	Hydraulic power unit
N.C.	Normally closed
N.O	Normally open
*N	Note with description
*N8	110V AC motor detail
*N9	220V AC terminal strip detail
*N10	220V AC motor detail
*N17	Narrow platform units: WH and BK wires replace BL and OR wires
*N27	Units without plug: WH and BK wires replace BL and BN wires
*N28	For 240V operation jumper brown to white through terminal strip and leave black unconnected as shown (CB4 = 8A, CB9 = 3A) For 120V operation jumper brown to black and blue to white as shown with dashed lines (CB4 = 15A, CB9 = 6A)
*N29	(N) Denotes a neutral wire to be tagged with an (N) sleeve
*N30	110V AC / 220V AC terminal strip detail
P	Power switch
P1	Emergency Stop button at ground controls
P2	Emergency Stop button at platform controls
P3	Emergency Stop button at steer handle controls (IWP)
PR	Power relay
PR4	Function pump (M5)



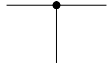

Electrical Component and Wire Color Legends

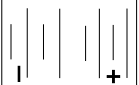
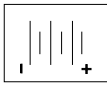
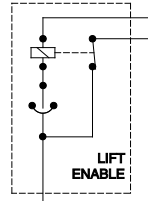
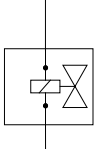
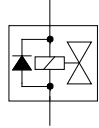
Item	Description	Color	Description
QD	Quick disconnect	BK	Black
QD1	Battery quick disconnect	BK/RD	Black/Red
QD3	Control cable – to platform control box	BL	Blue
QD4	Control cable – to base	BL/BK	Blue/Black
QD7	Control cable – to motor	BL/OR	Blue/Orange
S7	Tilt sensor	BL/WH	Blue/White
SW	Switch	BR	Brown
SW 8	Control activate	GN	Green
SW11	Platform up/down	GN/BK	Green/Black
SW12	Auxiliary down	GN/WH	Green/White
SW13	Outrigger interlock – front left (AWP)	GR/YL	Green/Yellow
SW14	Outrigger interlock – front right (AWP)	LB	Light Blue
SW15	Outrigger interlock – rear left (AWP)	OR	Orange
SW16	Outrigger interlock – rear right (AWP)	OR/BK	Orange/Black
SW17	Foot pad, left side (IWP)	OR/RD	Orange/Red
SW18	Foot pad, right side (IWP)	OR/WH	Orange/White
SW21	Power assist, Direction – reversing safety switch (IWP)	RD	Red
SW22	Power assist, Forward/Reverse switch (IWP)	RD/BK	Red/Black
SW24	Power assist, Lift enable (IWP)	RD/WH	Red/White
U	Electronic component	WH	White
U9	Transformer	WH/BK	White/Black
U10	PC board	YL	Yellow
U12	Thermal device		
W	Wiring component		
W3	Terminal strip – 3 pole 3 pin (U10)		
W4	Terminal strip – 14 pole 14 pin (U10)		
W5	Terminal strip – 13 pole 26 pin (*N7,*N9)		
W6	Terminal strip – 8 pole 16 pin (base) (AWP)		
W6	Terminal strip – 10 pole 20 pin (base) (IWP)		
Y	Valve coil		
Y5	Drive forward (IWP)		
Y6	Drive reverse (IWP)		
Y7	Platform down		
Y30	Normally open dump valve		
Y32	Function solenoid (IWP)		

Electrical Symbol Legend

 <p>Wire with description or color</p>	 <p>Limit Switch</p>	 <p>Toggle Switch</p>	 <p>Switch</p>
 <p>Circuits crossing no connection</p>	 <p>Emergency Stop button</p>	 <p>Fuse</p>	 <p>Circuit breaker</p>
 <p>Diode</p>	 <p>LED</p>	 <p>Motor</p>	 <p>U12 Thermal Device</p>
 <p>Circuit connection</p>	 <p>Connector</p>	 <p>8 AA Batteries</p>	 <p>12V Battery (s)</p>
 <p>Lift Enable</p>	 <p>Solenoid Valve</p>	 <p>Solenoid valve with diode</p>	

Hydraulic Symbols Legend

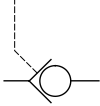
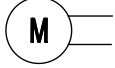
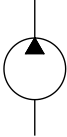
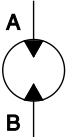
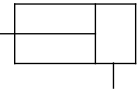
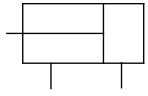
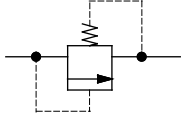
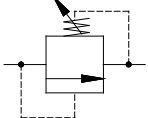
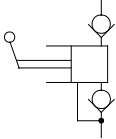
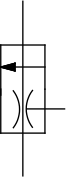
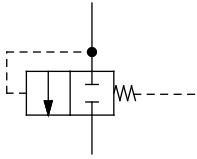
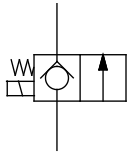
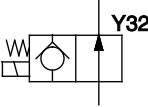
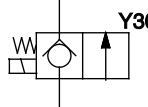
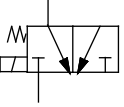
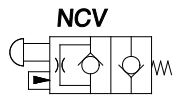
			
Filter	Orifice with size	Check valve	Pressure Gauge
			
Check Valve, pilot operated	Pump prime mover, electric motor	Fixed displacement pump	Wheel motor, fixed displacement
			
Cylinder, single acting	Cylinder, double acting	Relief valve	Adjustable relief valve
			
Foot pump valve	Priority flow regulator	Differential sensing valve	Solenoid operated dump valve
			
Solenoid operated 2 position 2 way valve, normally open	Solenoid operated, 2 position 2 way valve, normally closed	Solenoid operated 2 position 2 way directional valve	Button operated 2 position 2 way directional valve

This page intentionally left blank.



Electrical Schematic - AWP Super Series DC Models
(from SN 3896-101 to 3896-300)

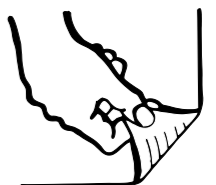

Electrical Schematic - AWP Super Series DC Models
(from SN 3896-101 to 3896-300)

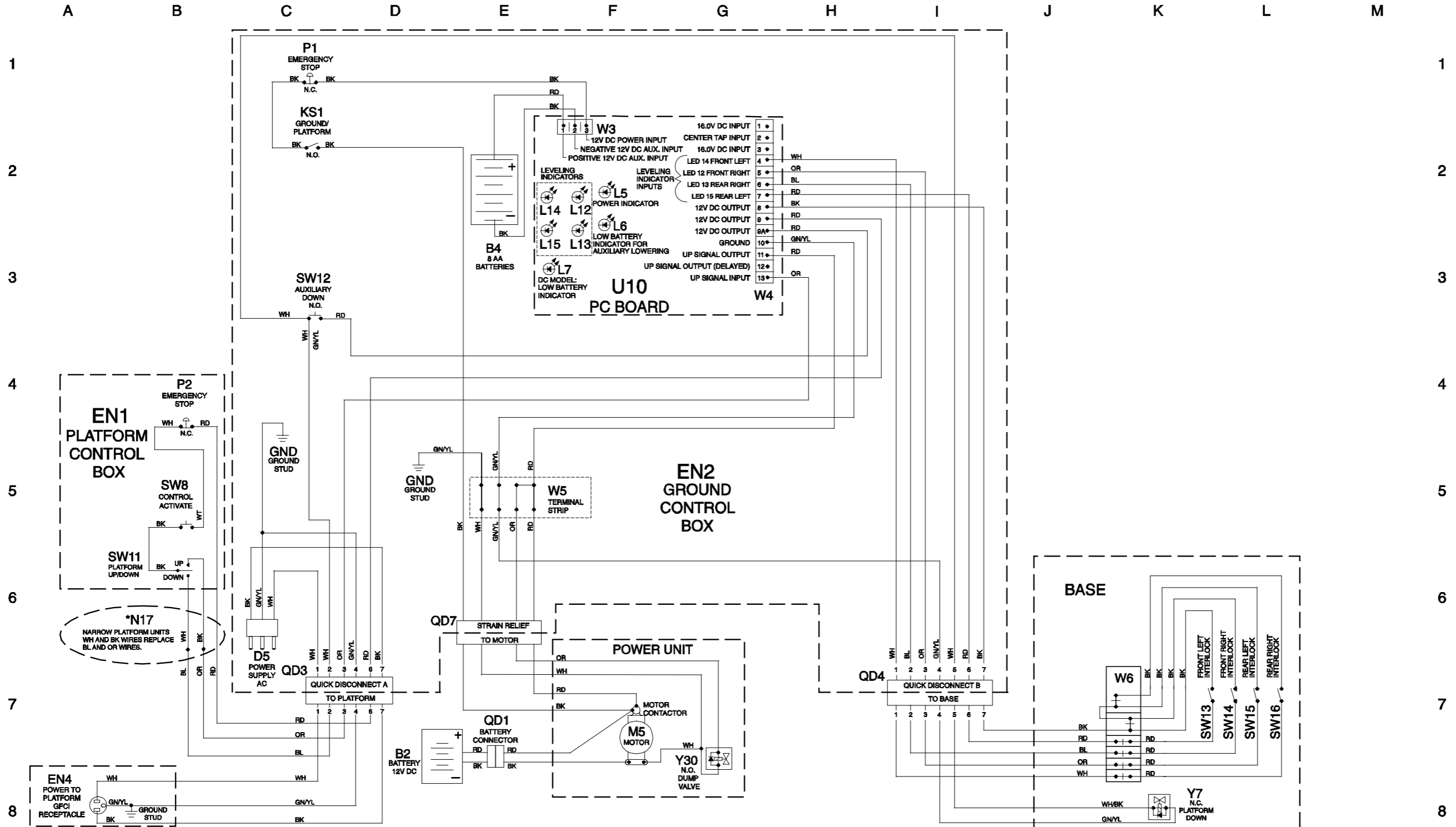

Electrical Schematic - AWP Super Series DC Models
(from SN 3896-301 to 3896-430)

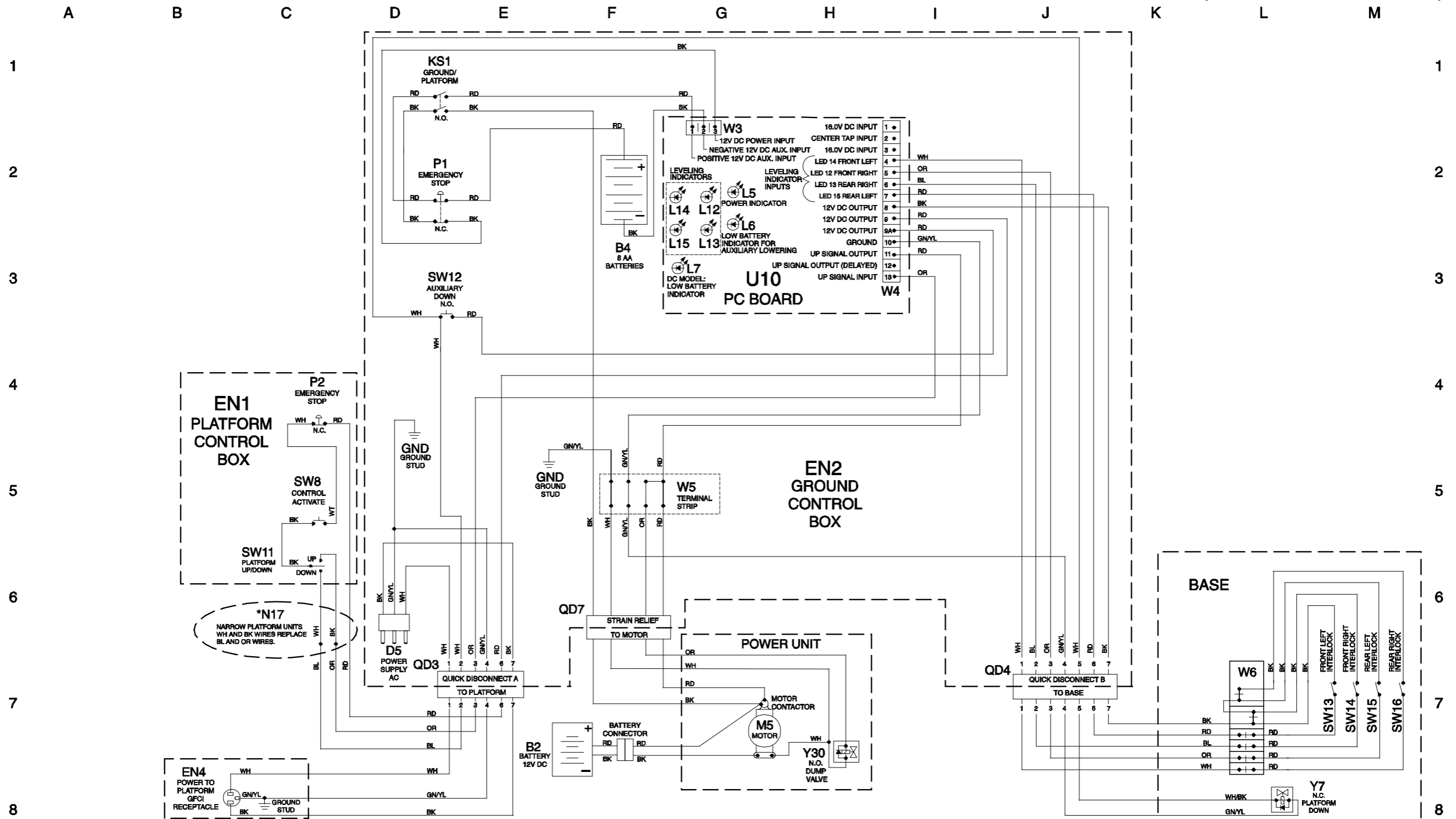

Electrical Schematic - AWP Super Series DC Models
(from SN 3896-301 to 3896-430)

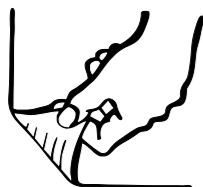

Electrical Schematic - AWP Super Series DC Models
(from SN 3896-431 to AWP07-54898)

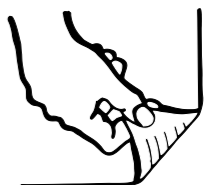

Electrical Schematic - AWP Super Series DC Models
(from SN 3896-431 to AWP07-54898)

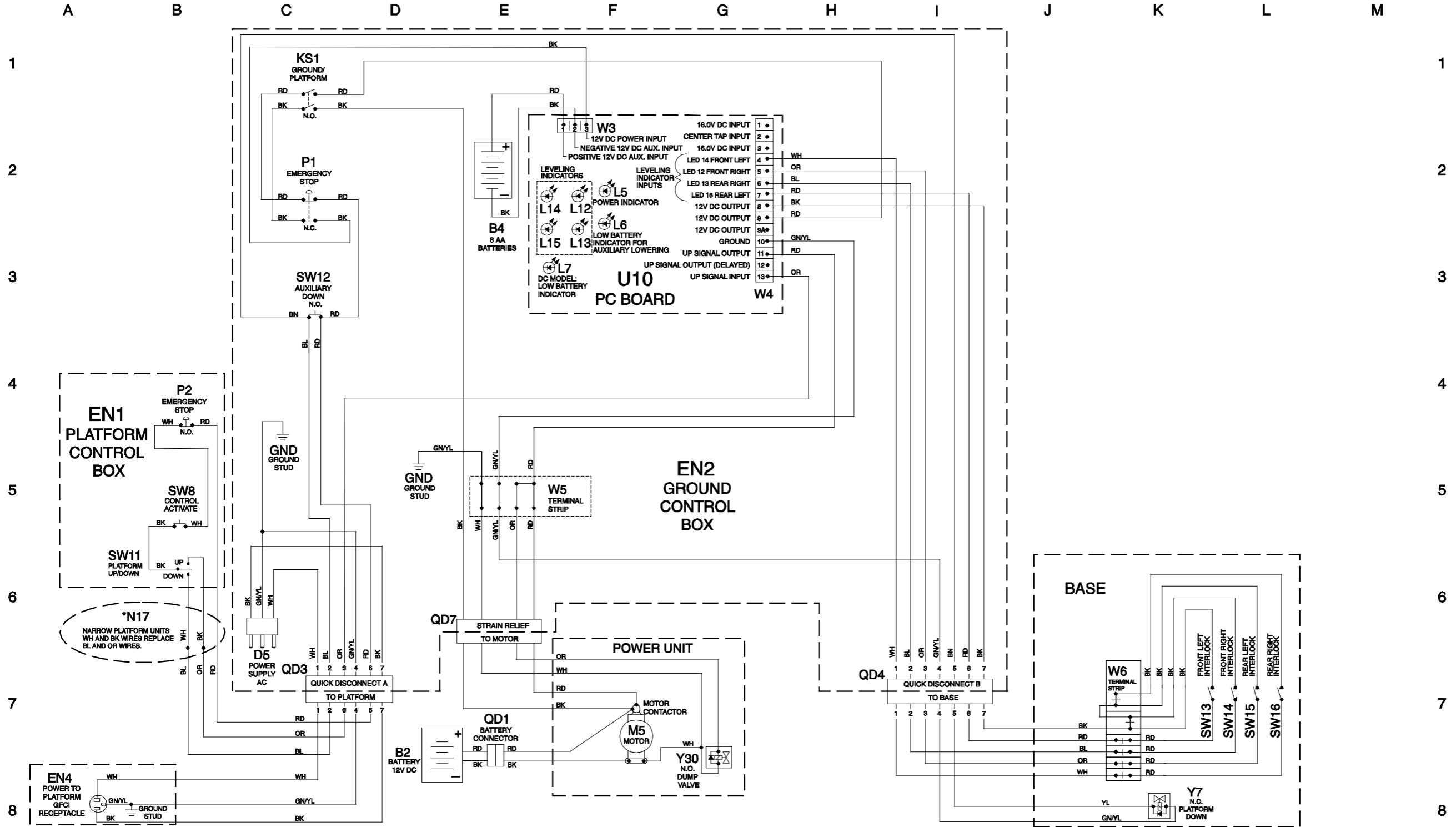

Electrical Schematic - AWP Super Series DC Models with Standard Base
(from SN AWP07-54899)

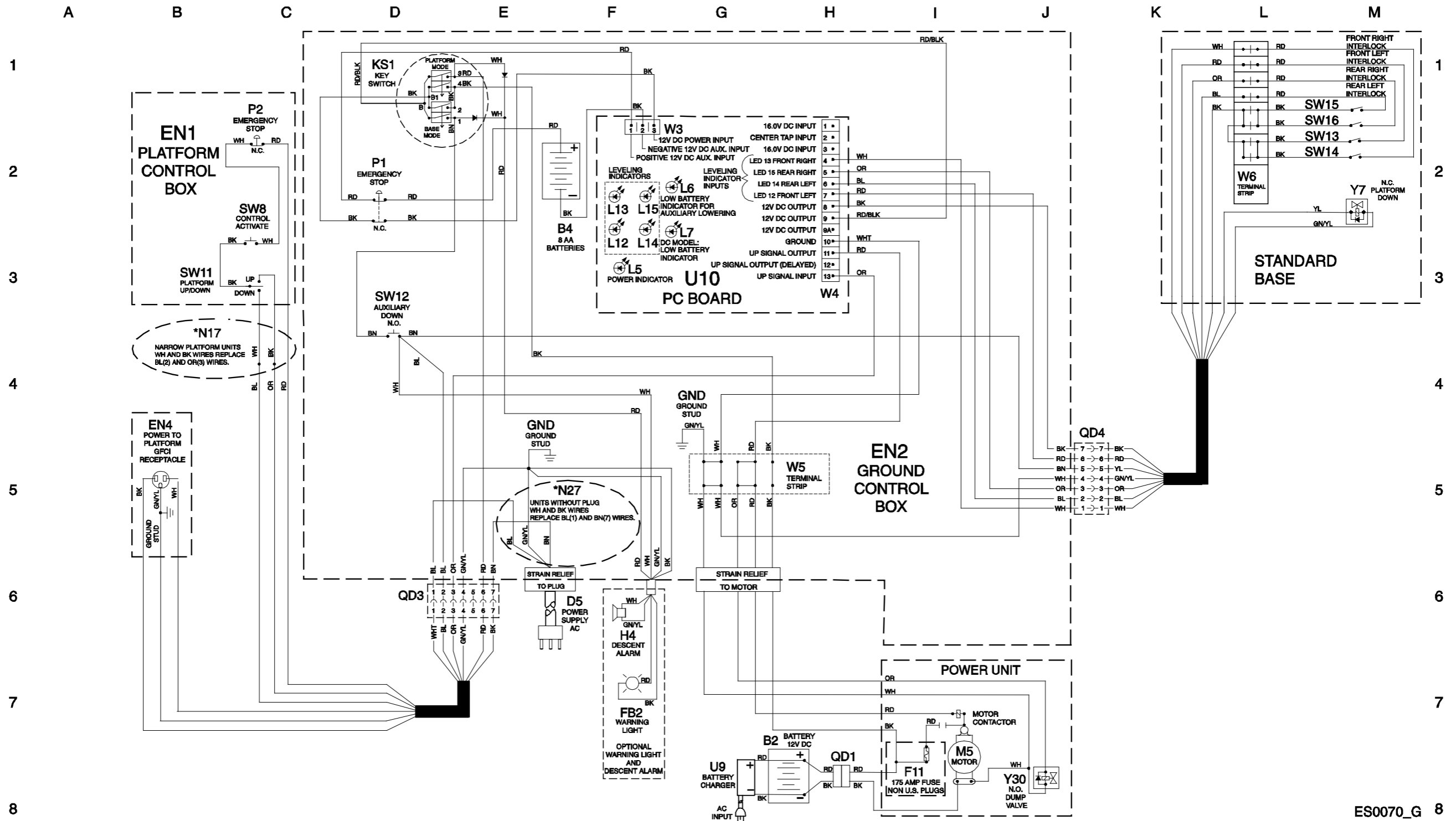

ES0070_G 8

Electrical Schematic - AWP Super Series DC Models with Standard Base
(from SN AWP07-54899)

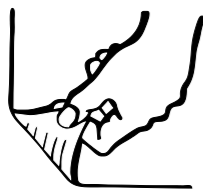

Electrical Schematic - AWP Super Series DC Models with Narrow Base
(from SN AWP07-54899)

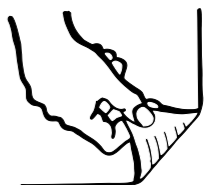

Electrical Schematic - AWP Super Series DC Models with Narrow Base
(from SN AWP07-54899)

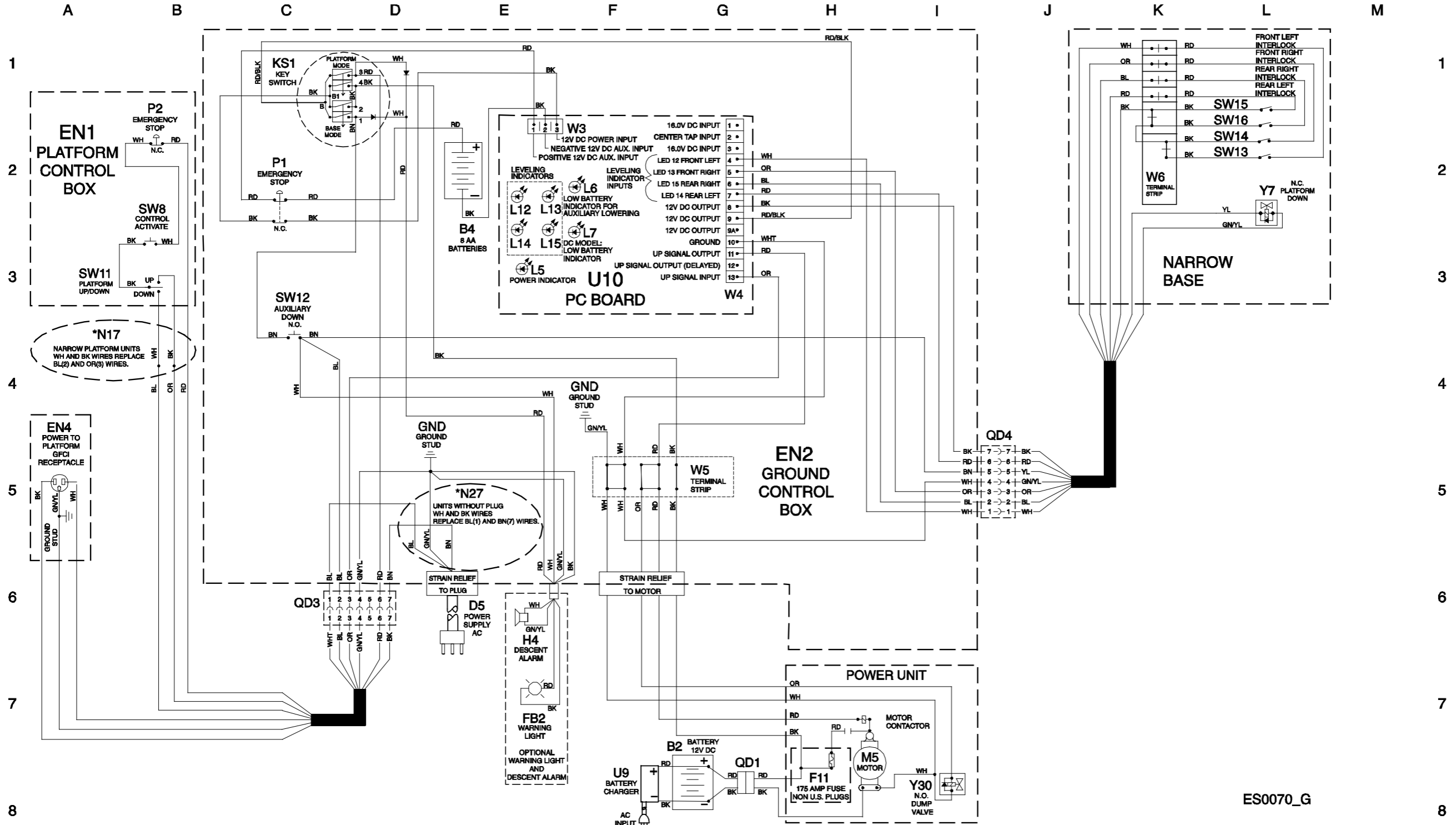

Electrical Schematic - AWP Super Series DC CE Models
(from SN 3896-432 to AWP07-54898)

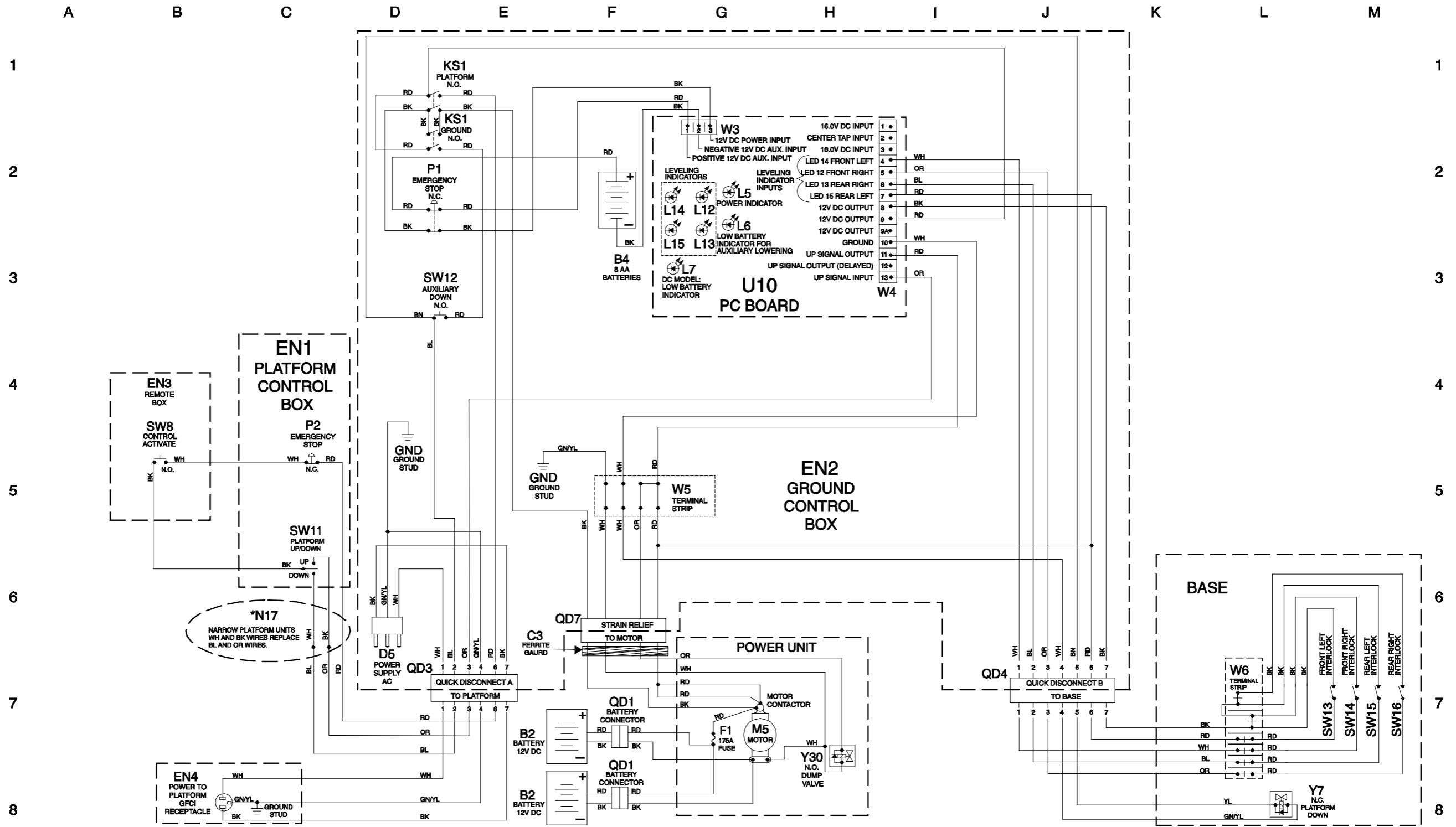

Electrical Schematic - AWP Super Series DC CE Models
(from SN 3896-432 to AWP07-54898)

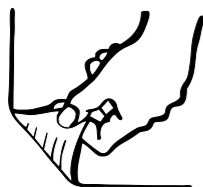

Electrical Schematic - AWP Super Series DC CE Models with Standard Base
(from SN AWP07-54899)

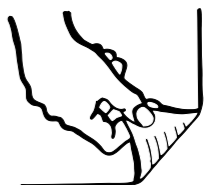

Electrical Schematic - AWP Super Series DC CE Models with Standard Base
(from SN AWP07-54899)

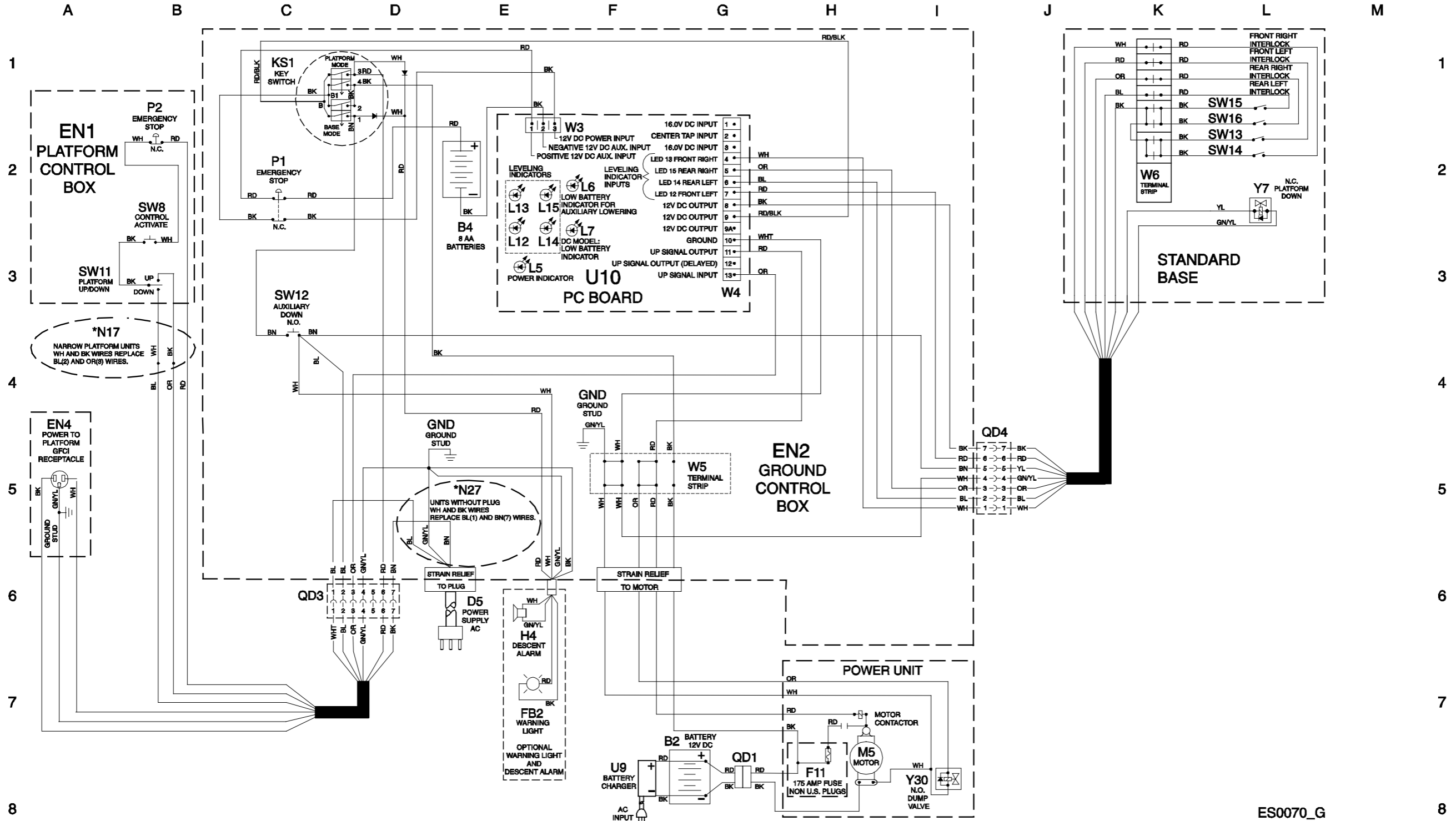

Electrical Schematic - AWP Super Series DC CE Models with Narrow Base
(from SN AWP07-54899)

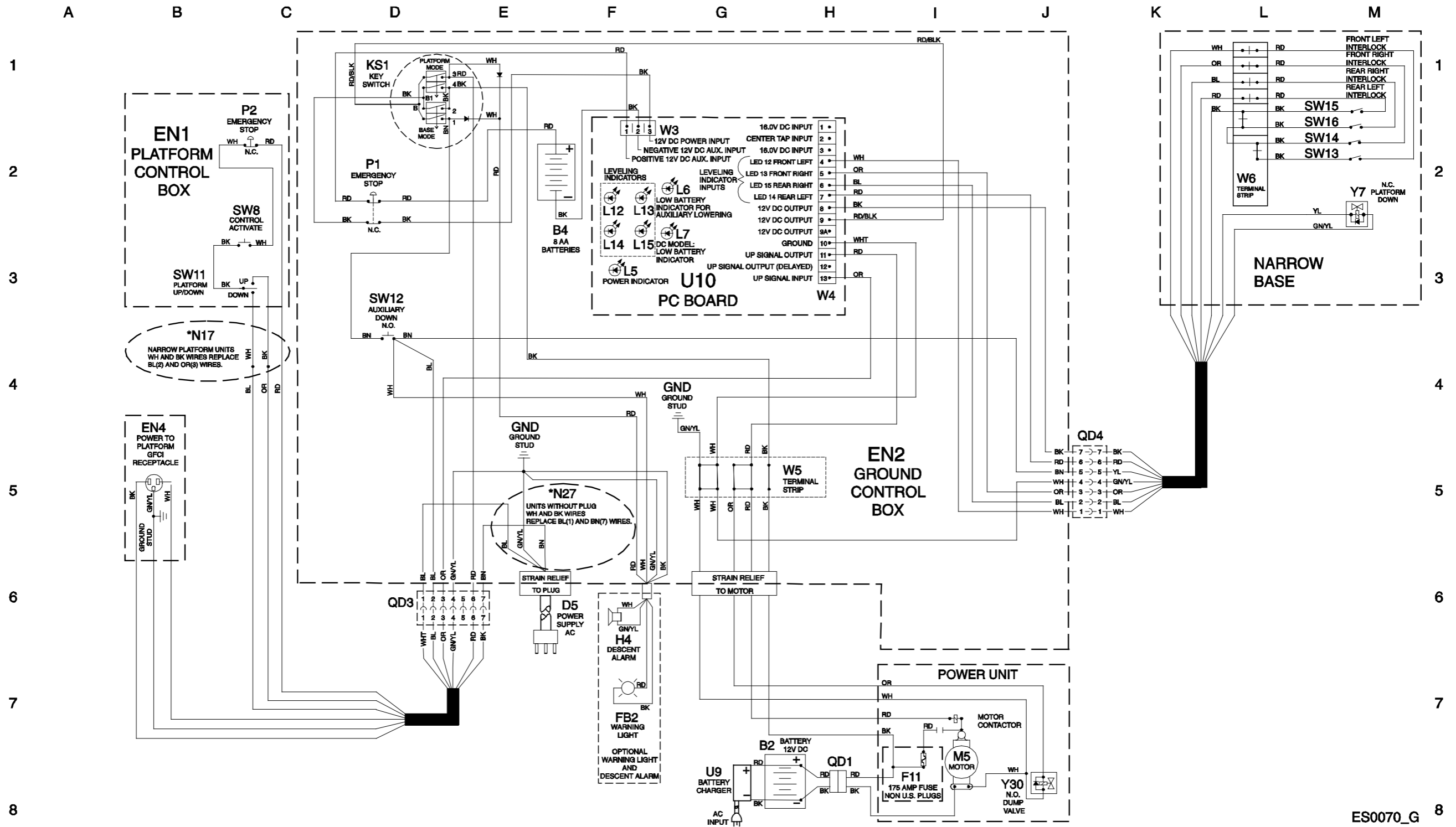

ES0070_G 8



Electrical Schematic - AWP Super Series DC CE Models with Narrow Base
(from SN AWP07-54899)

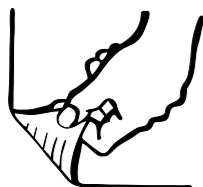

Electrical Schematic - AWP Super Series DC TUV Models
(from 3896-431)

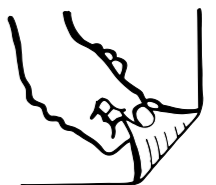

Electrical Schematic - AWP Super Series DC TUV Models
(from SN 3896-431)

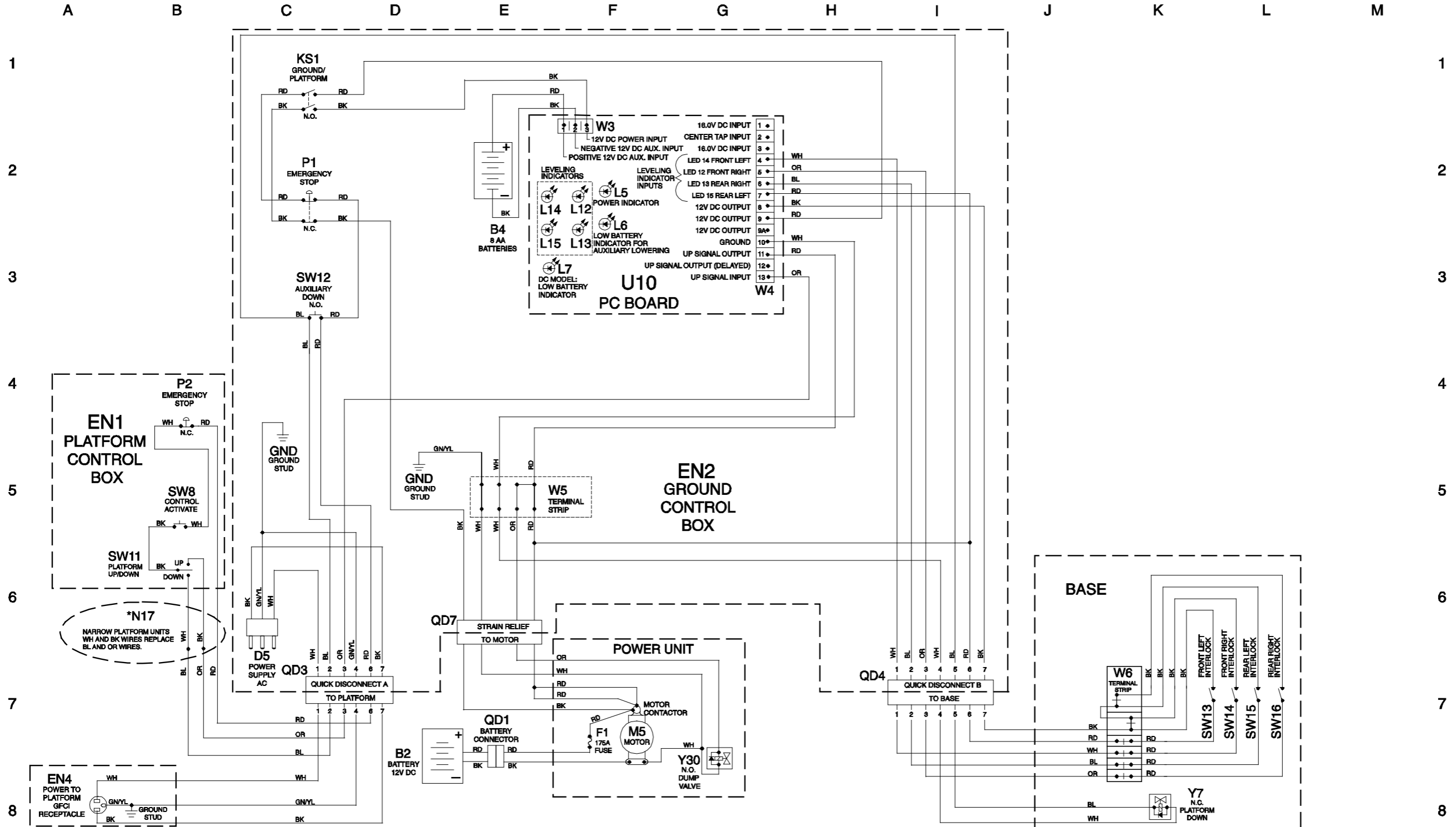

Electrical Schematic - AWP Super Series AC Models
(from SN 3896-103 to 3896-303)

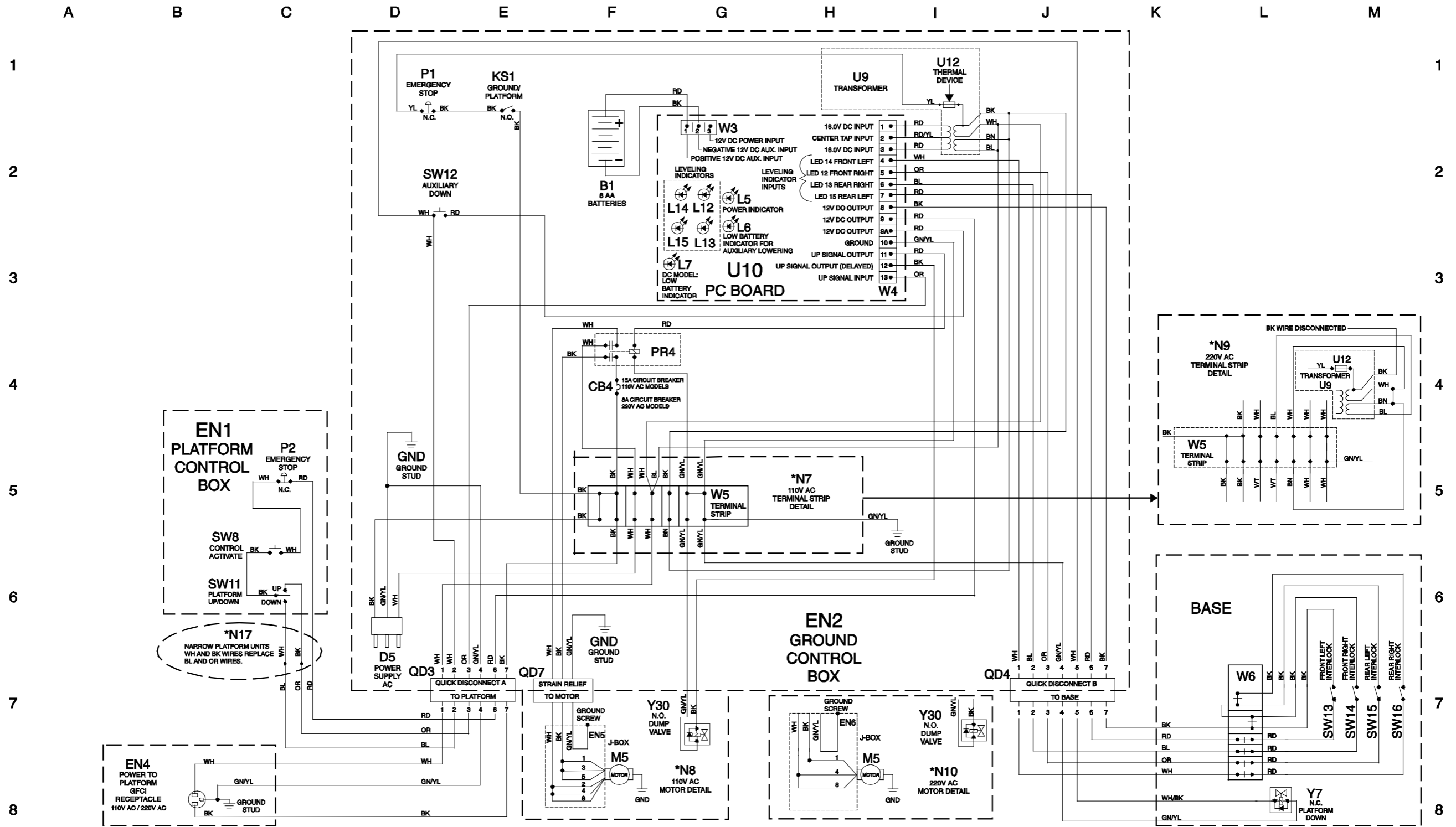

Electrical Schematic - AWP Super Series AC Models
(from SN 3896-103 to 3896-303)

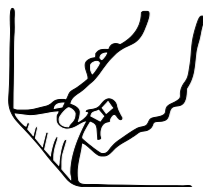

Electrical Schematic - AWP Super Series AC Models
(from SN 3896-304 to 3896-450)

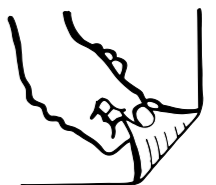

Electrical Schematic - AWP Super Series AC Models
(from SN 3896-304 to 3896-450)

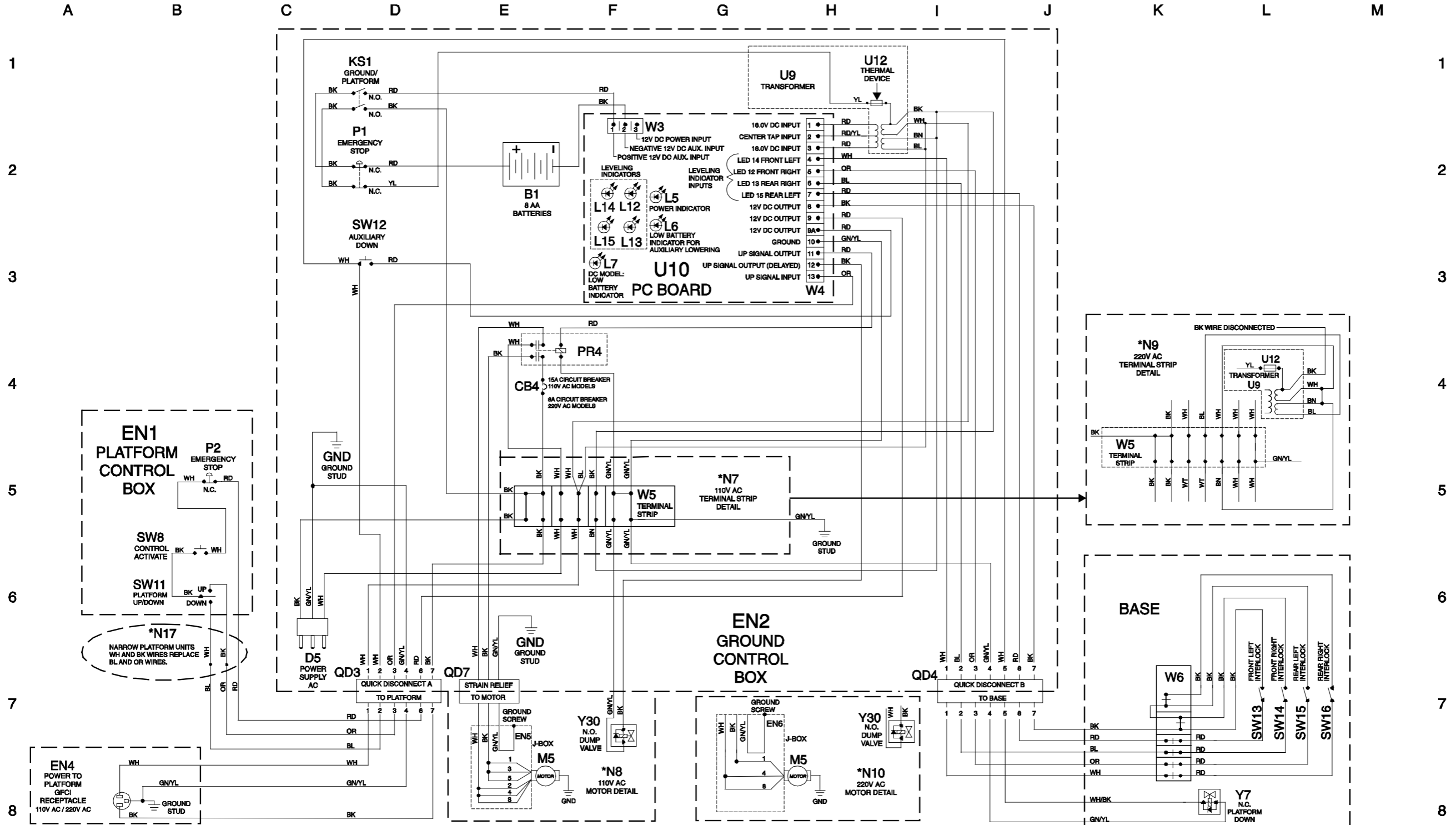

Electrical Schematic - AWP Super Series AC Models
(from SN 3896-451 to AWP07-54898)

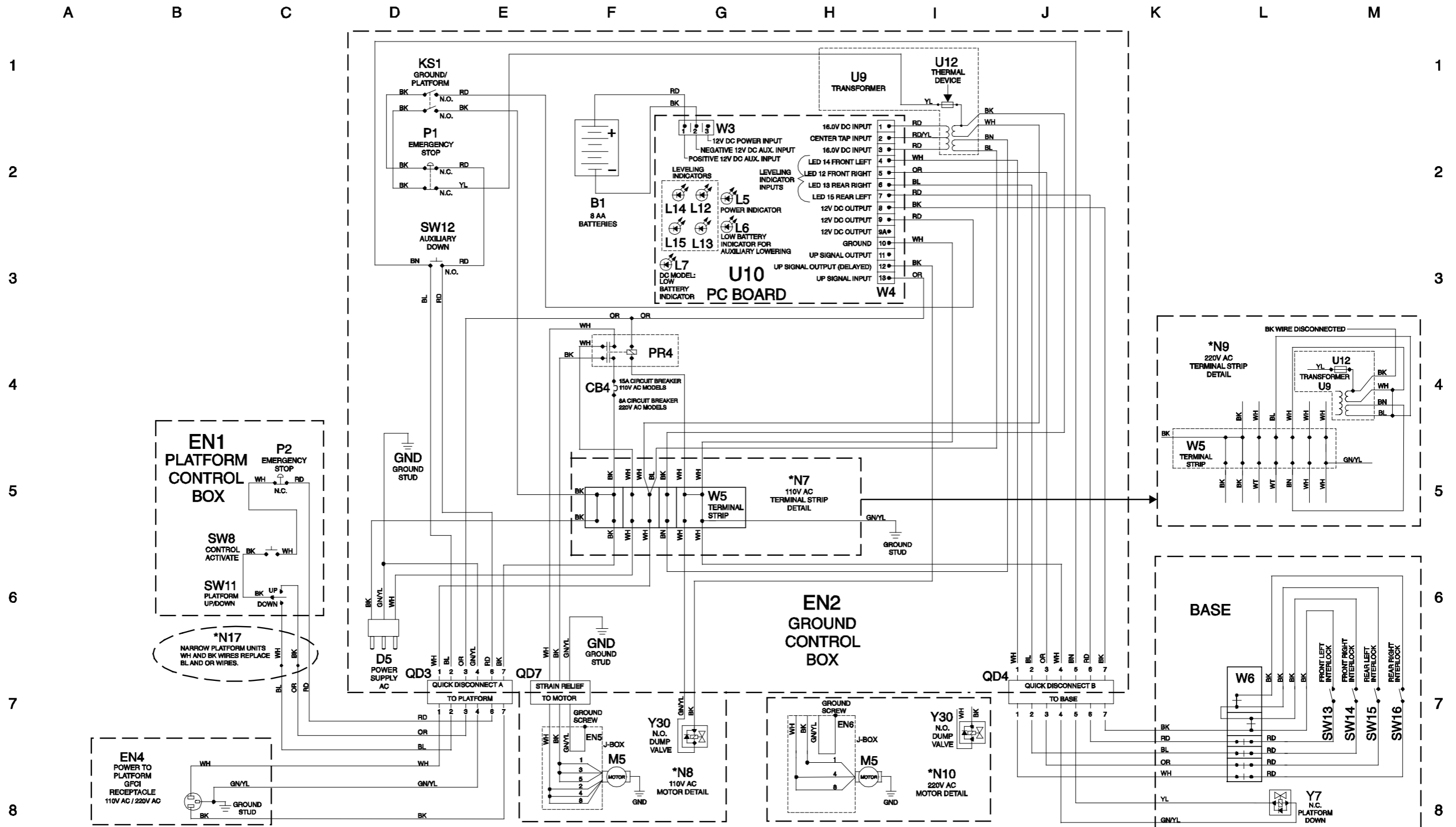

Electrical Schematic - AWP Super Series AC Models
(from SN 3896-451 to AWP07-54898)

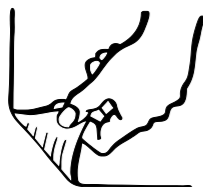

Electrical Schematic - AWP Super Series AC Models with Standard Base
(from SN AWP07-54899 to AWP07-57594)

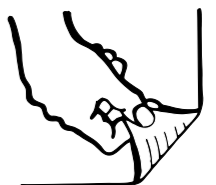

Electrical Schematic - AWP Super Series AC Models with Standard Base
 (from SN AWP07-54899 to AWP07-57594)

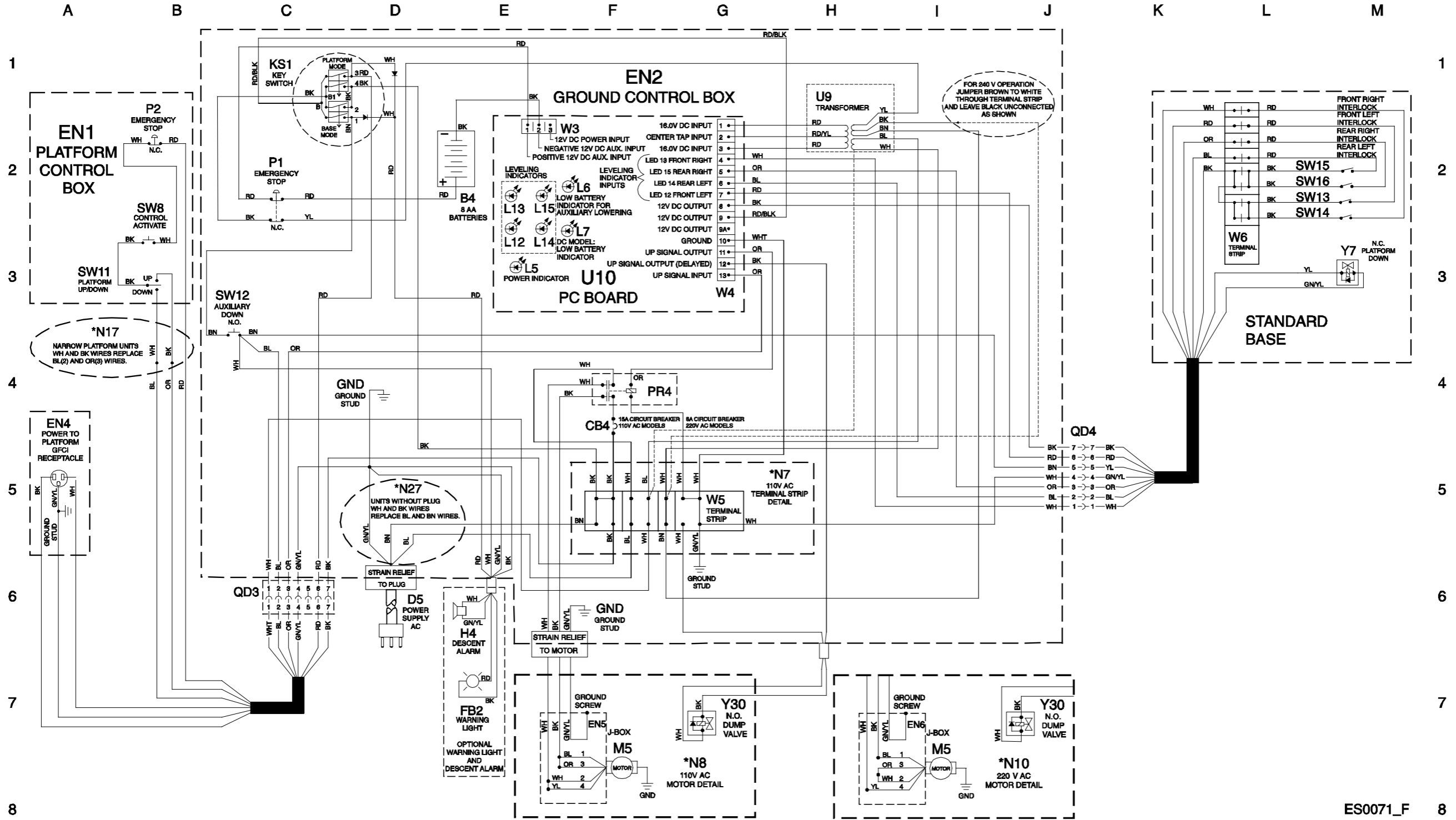

Electrical Schematic - AWP Super Series AC Models with Narrow Base
(from SN AWP07-54899 to AWP07-57594)

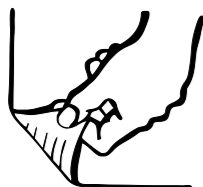

Electrical Schematic - AWP Super Series AC Models with Standard Base
(from SN AWP07-57595)

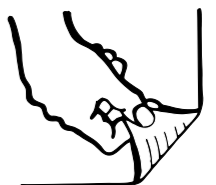

Electrical Schematic - AWP Super Series AC Models with Standard Base
(from SN AWP07-57595)

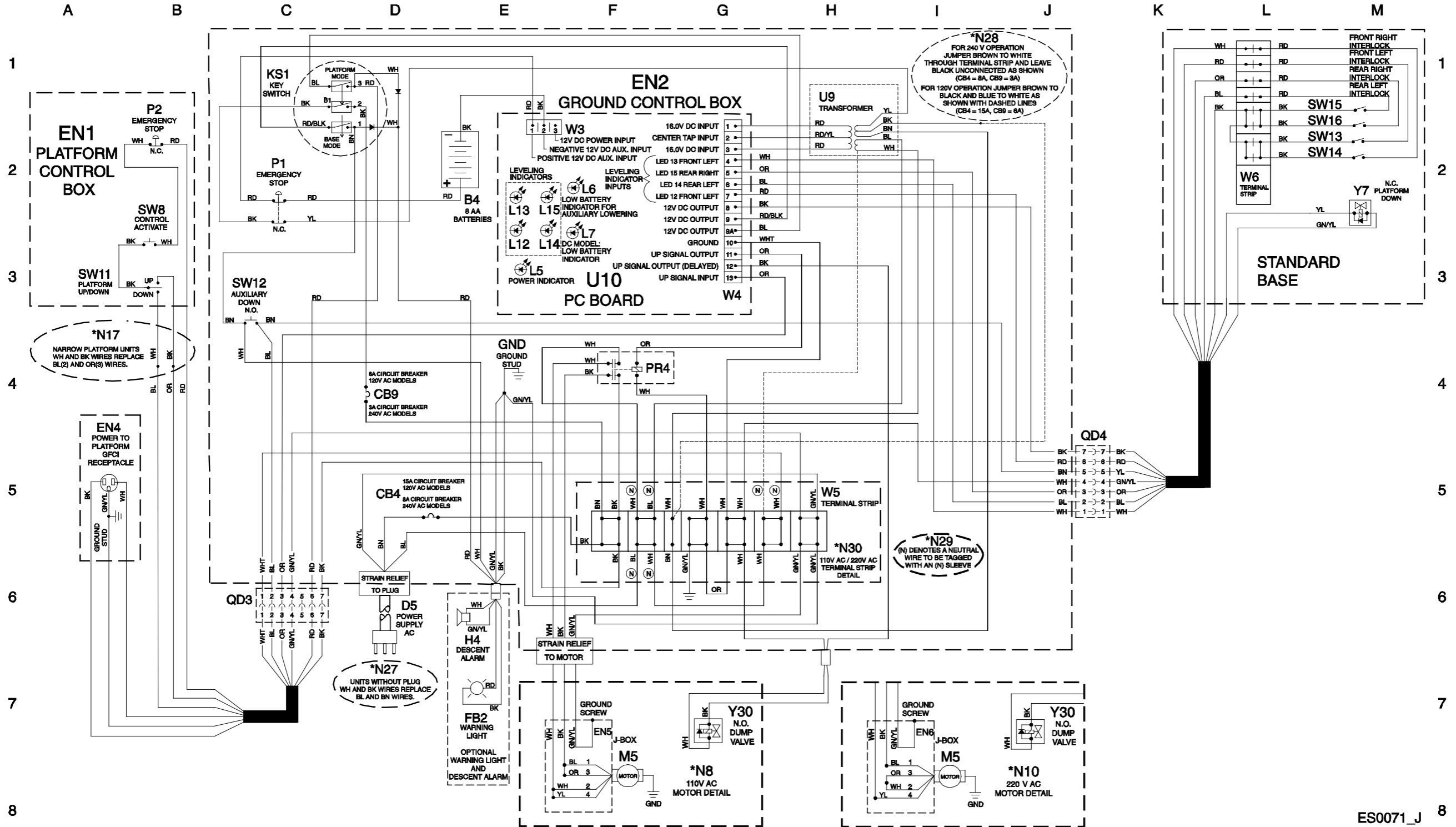

ES0071_J 8



Electrical Schematic - AWP Super Series AC Models with Narrow Base
(from SN AWP07-57595)

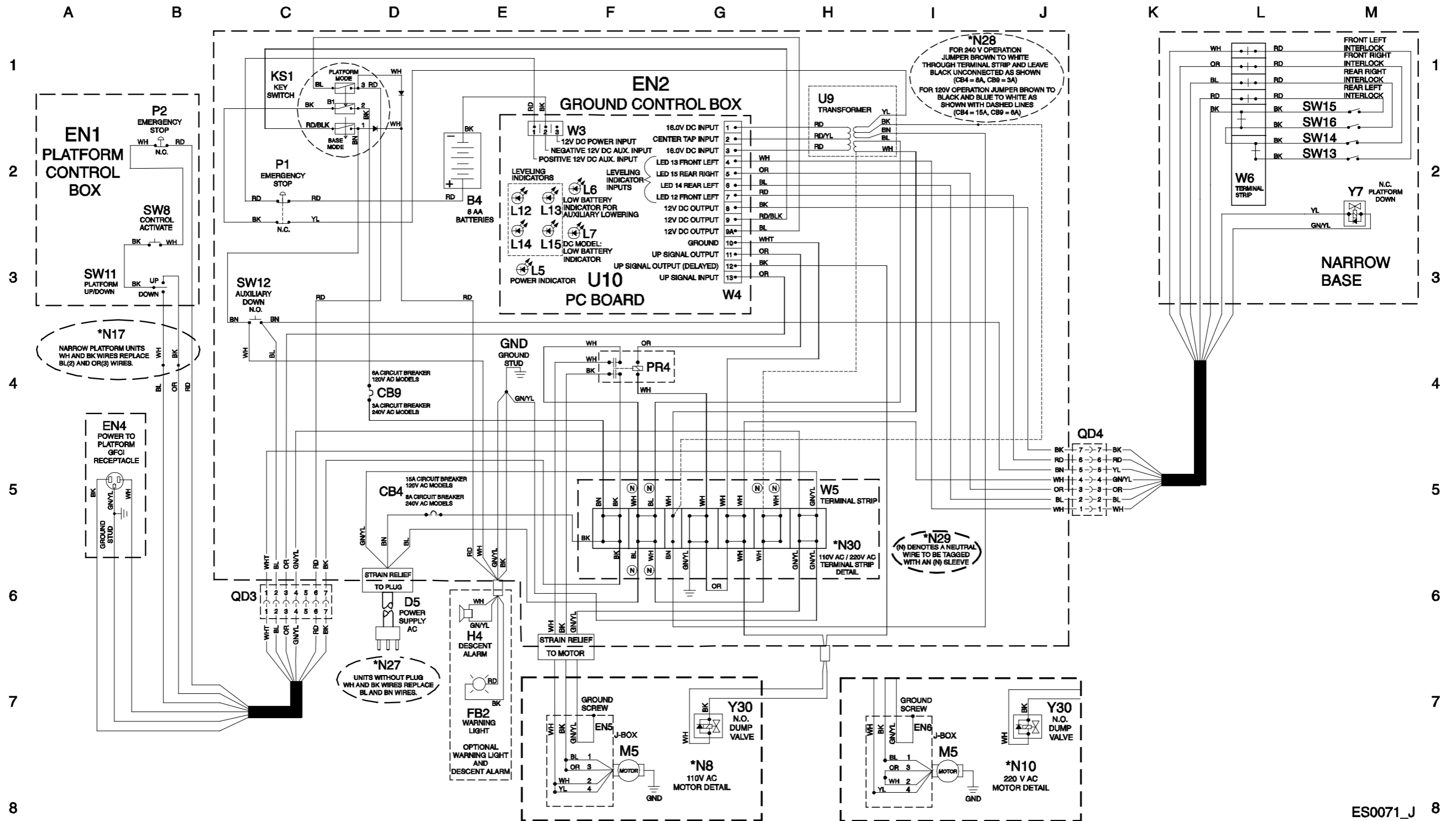

ES0071_J 8



Electrical Schematic - AWP Super Series AC Models with Narrow Base
(from SN AWP07-57595)

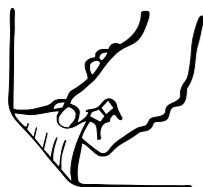

Electrical Schematic - AWP Super Series AC CE Models
(from SN 3896-451 to AWP07-54898)

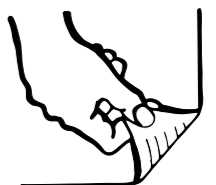

Electrical Schematic - AWP Super Series AC CE Models
(from SN 3896-451 to AWP07-54898)

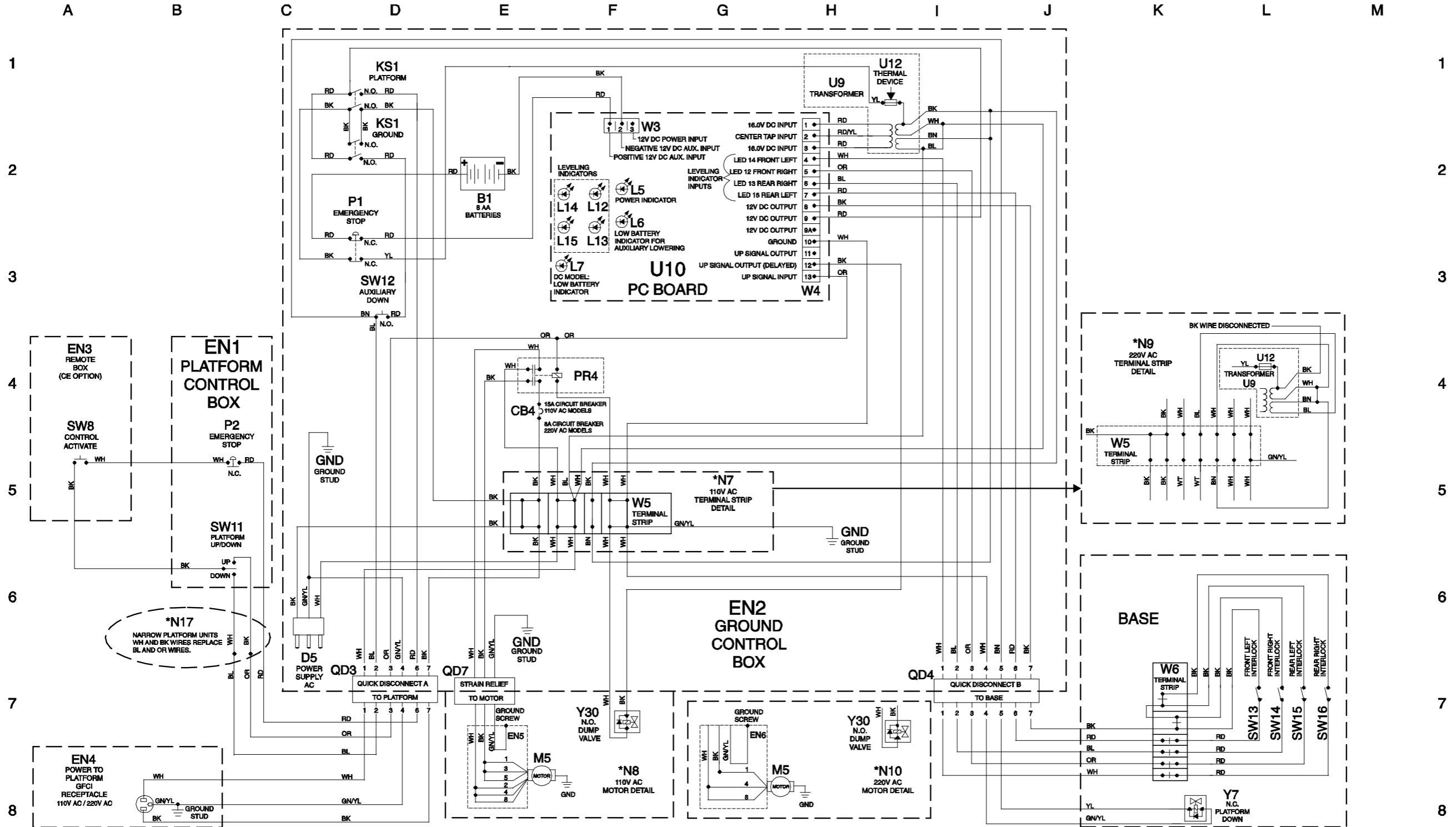

Electrical Schematic - AWP Super Series AC CE Models with Standard Base
(from SN AWP07-54899 to AWP07-57594)

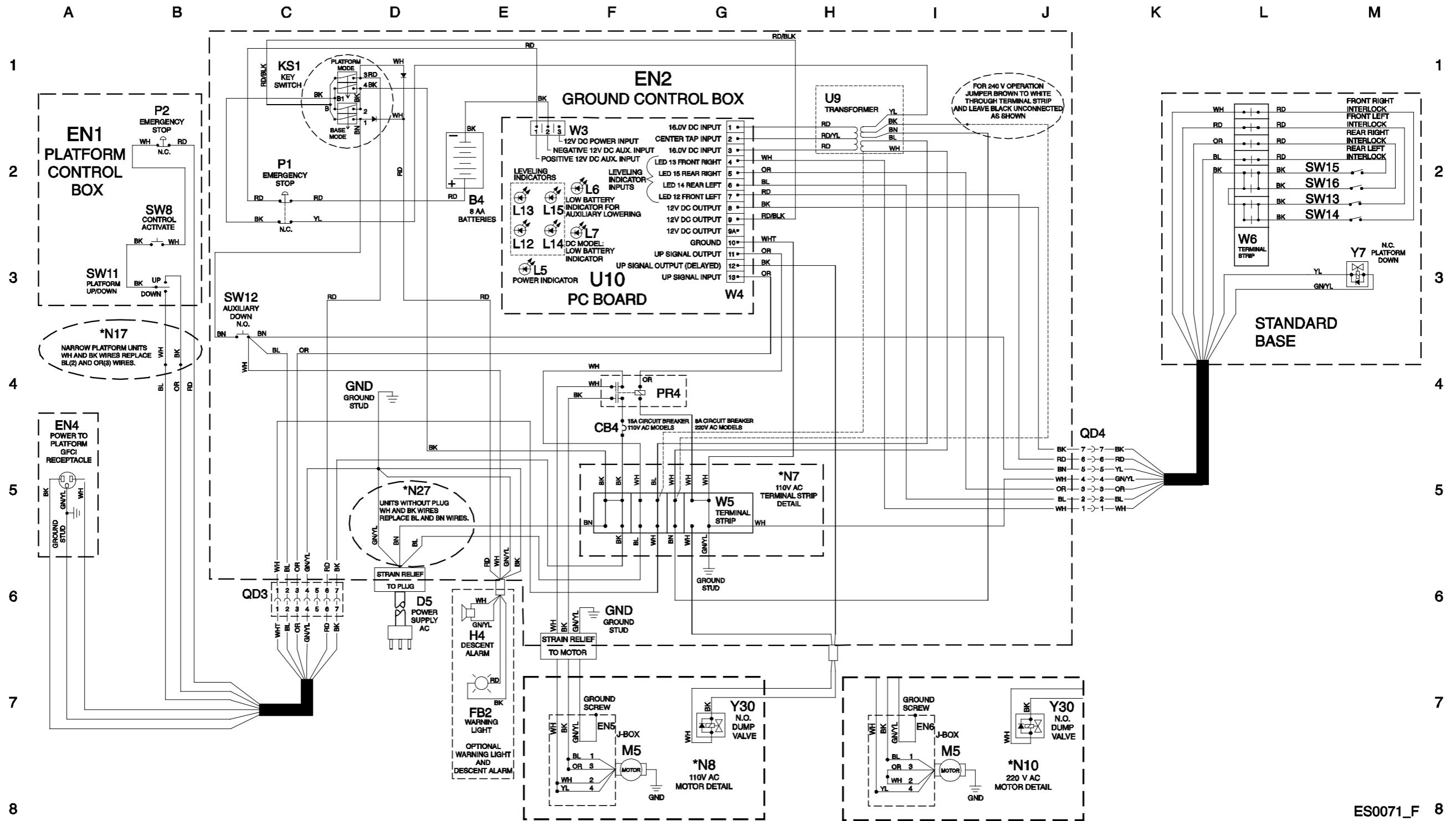

ES0071_F 8



Electrical Schematic - AWP Super Series AC CE Models with Standard Base
(from SN AWP07-54899 to AWP07-57594)

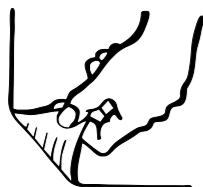

Electrical Schematic - AWP Super Series AC CE Models with Narrow Base
(from SN AWP07-54899 to AWP07-57594)

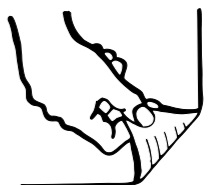

Electrical Schematic - AWP Super Series AC CE Models with Narrow Base
 (from SN AWP07-54899 to AWP07-57594)

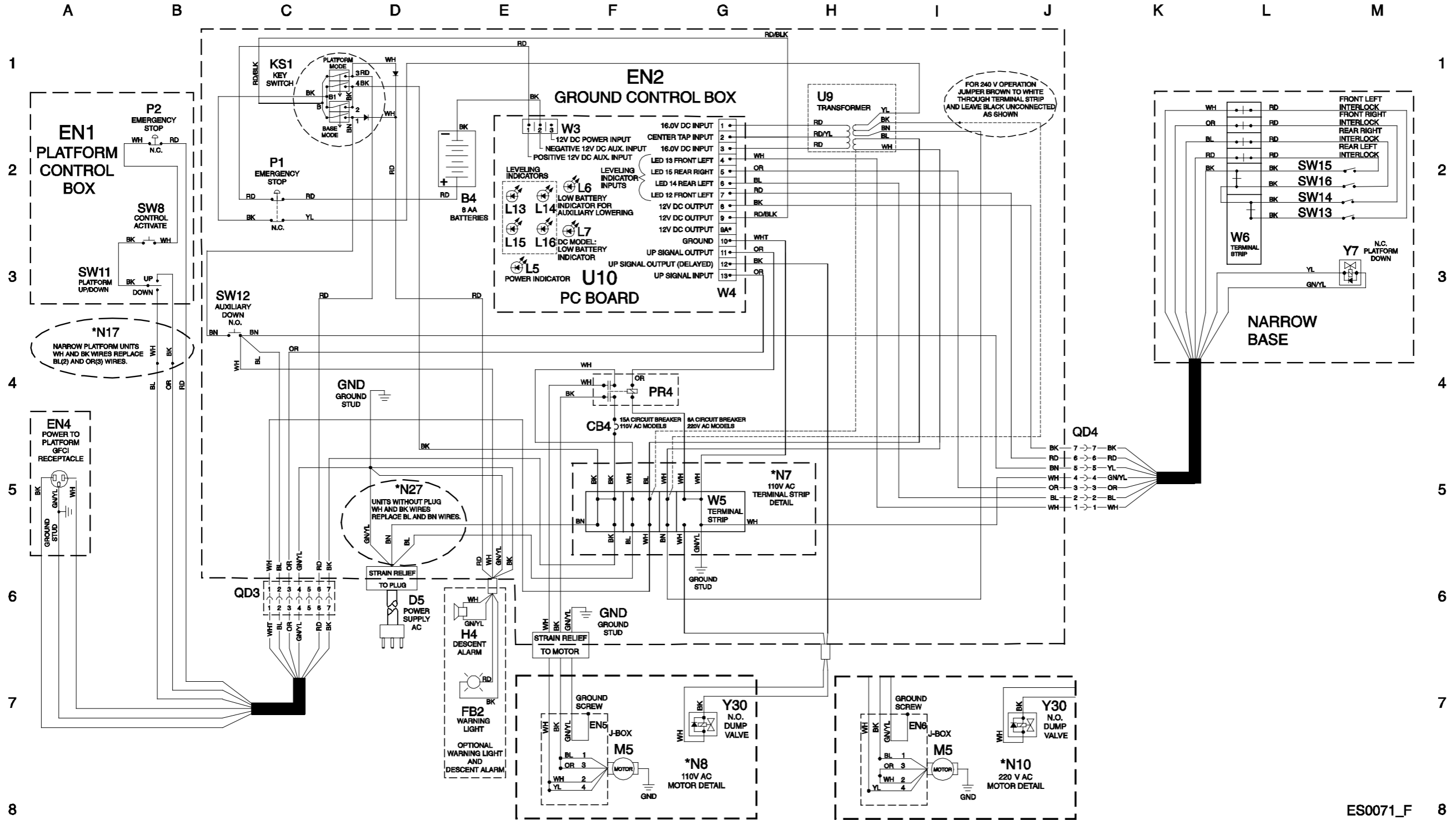

ES0071_F 8



Electrical Schematic - AWP Super Series AC CE Models with Standard Base
(from SN AWP07-57595)

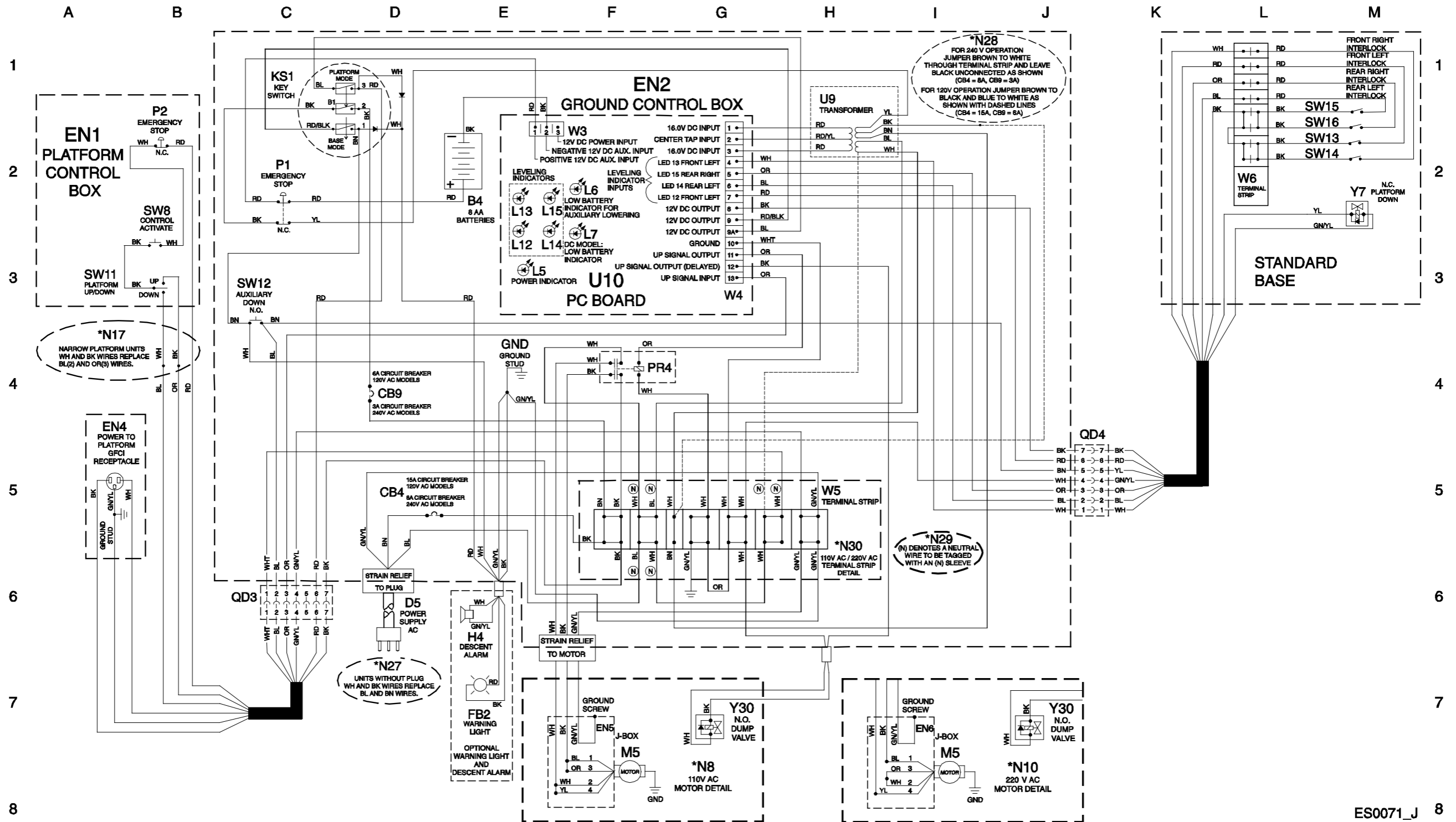

ES0071_J 8



Electrical Schematic - AWP Super Series AC CE Models with Standard Base
(from SN AWP07-57595)

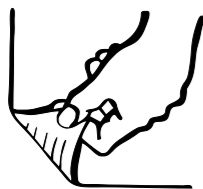

Electrical Schematic - AWP Super Series AC CE Models with Narrow Base
(from SN AWP07-57595)

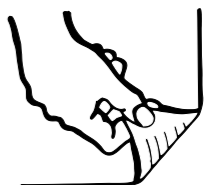

Electrical Schematic - AWP Super Series AC CE Models with Narrow Base
(from SN AWP07-57595)

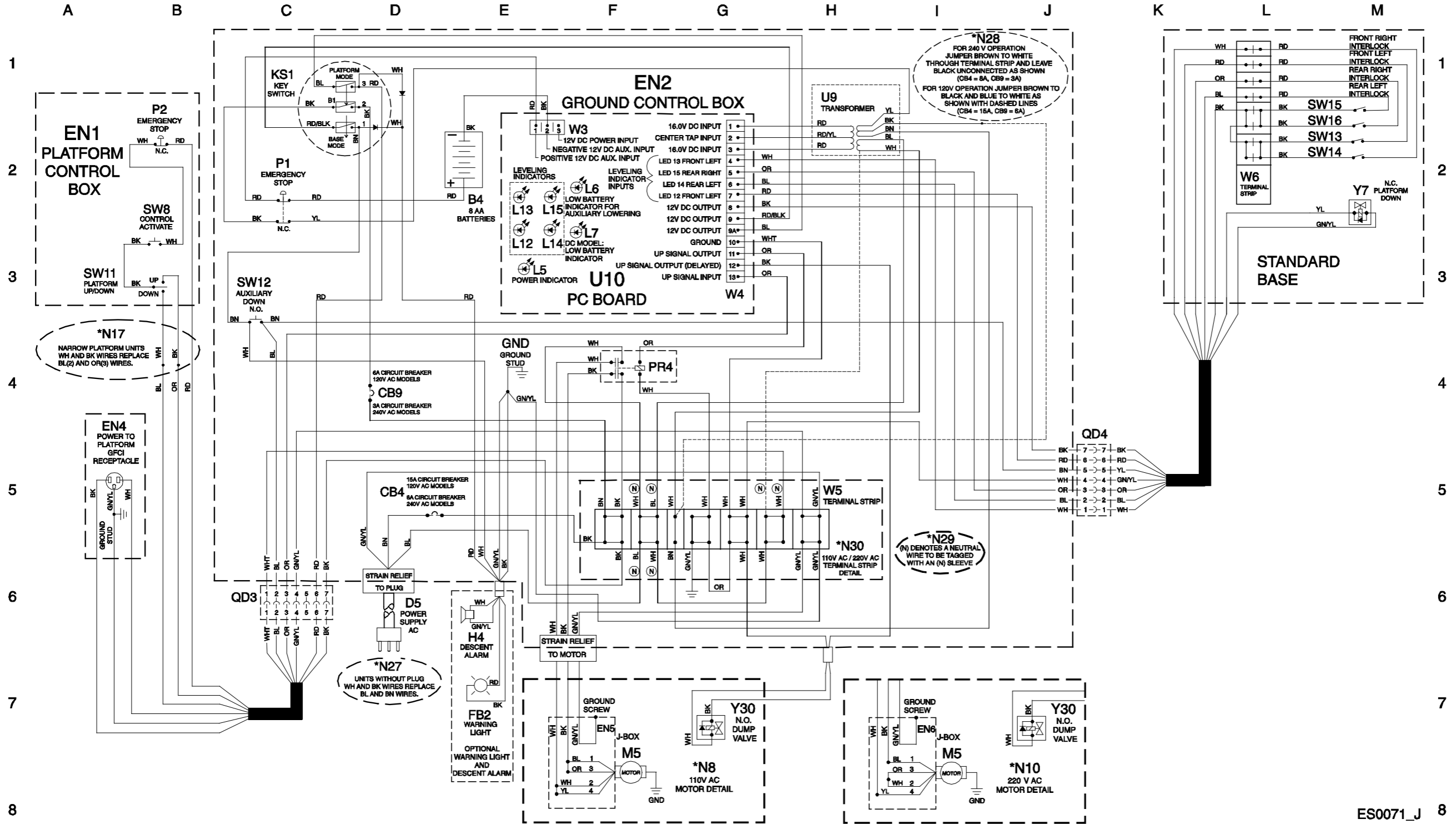

ES0071_J 8



Electrical Schematic - AWP Super Series AC TUV Models
(from SN 3896-461)

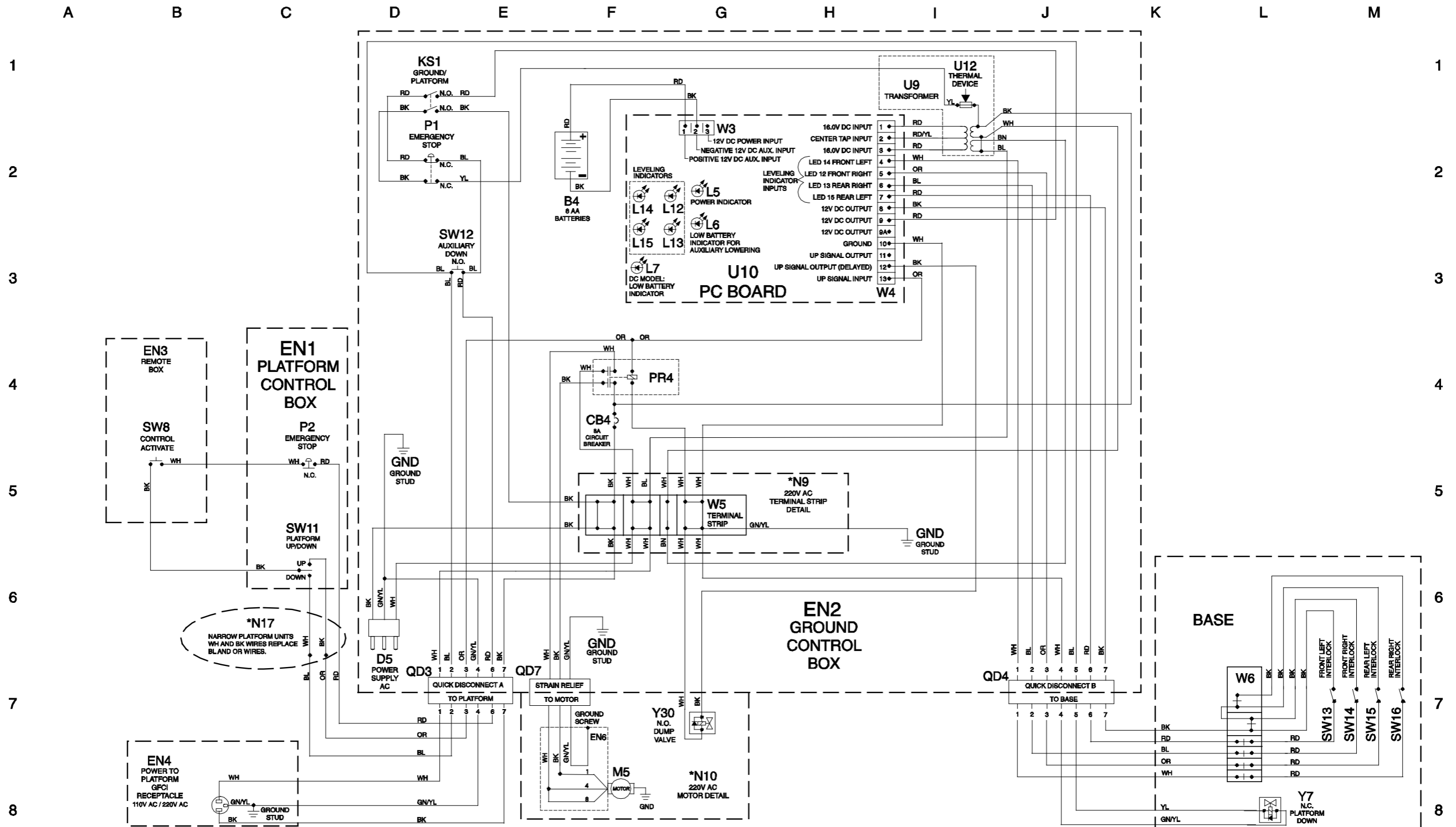

Electrical Schematic - AWP Super Series AC TUV Models
(from SN 3896-461)

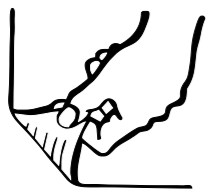

Electrical Schematic - IWP Super SeriesDC Models
(from SN 4096-101 to 4096-287)

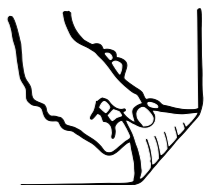

Electrical Schematic - IWP Super Series DC Models
(from SN 4096-101 to 4096-287)

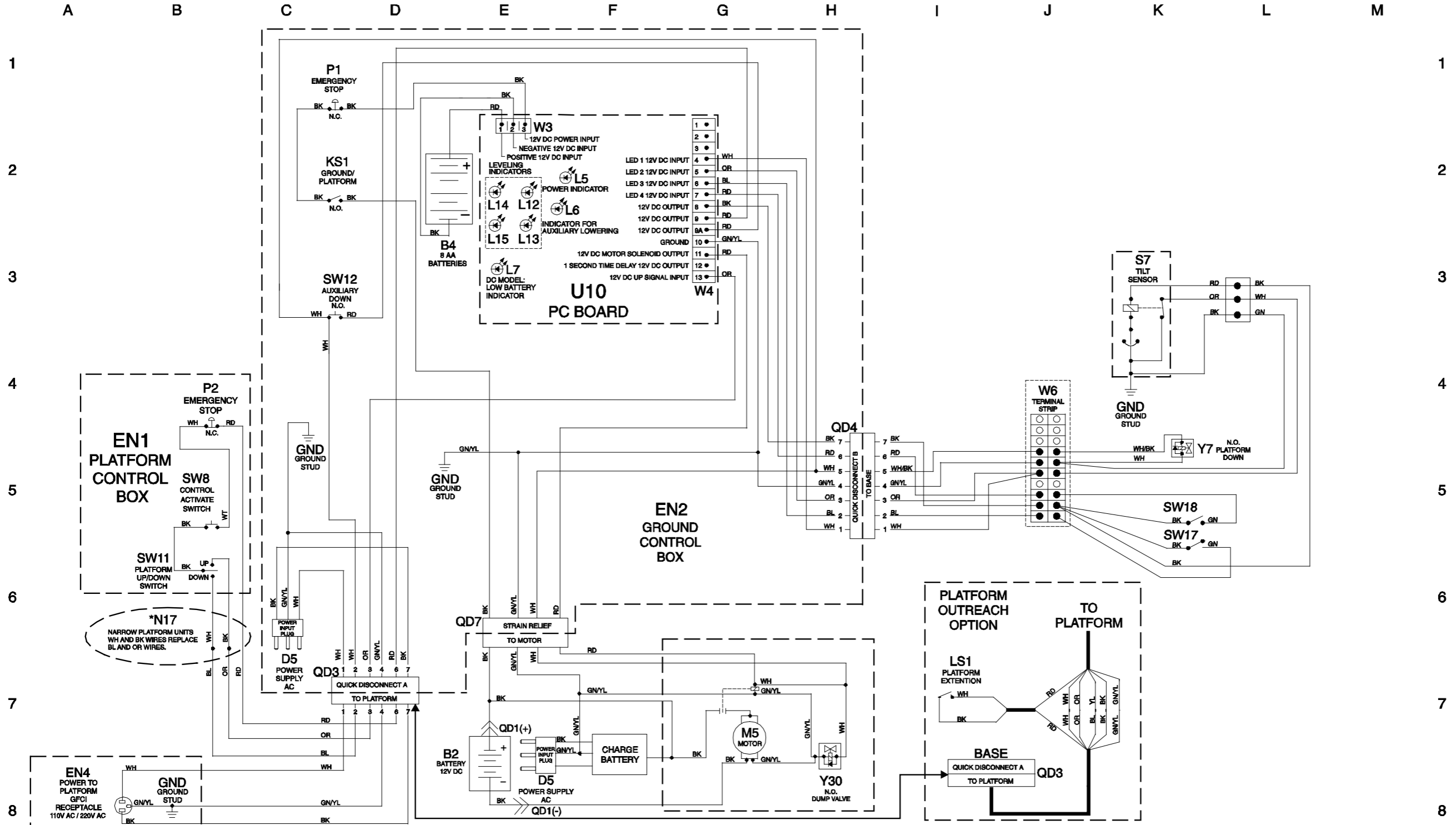

Electrical Schematic - IWP Super Series DC Models
(from SN 4096-288 to 4096-341)

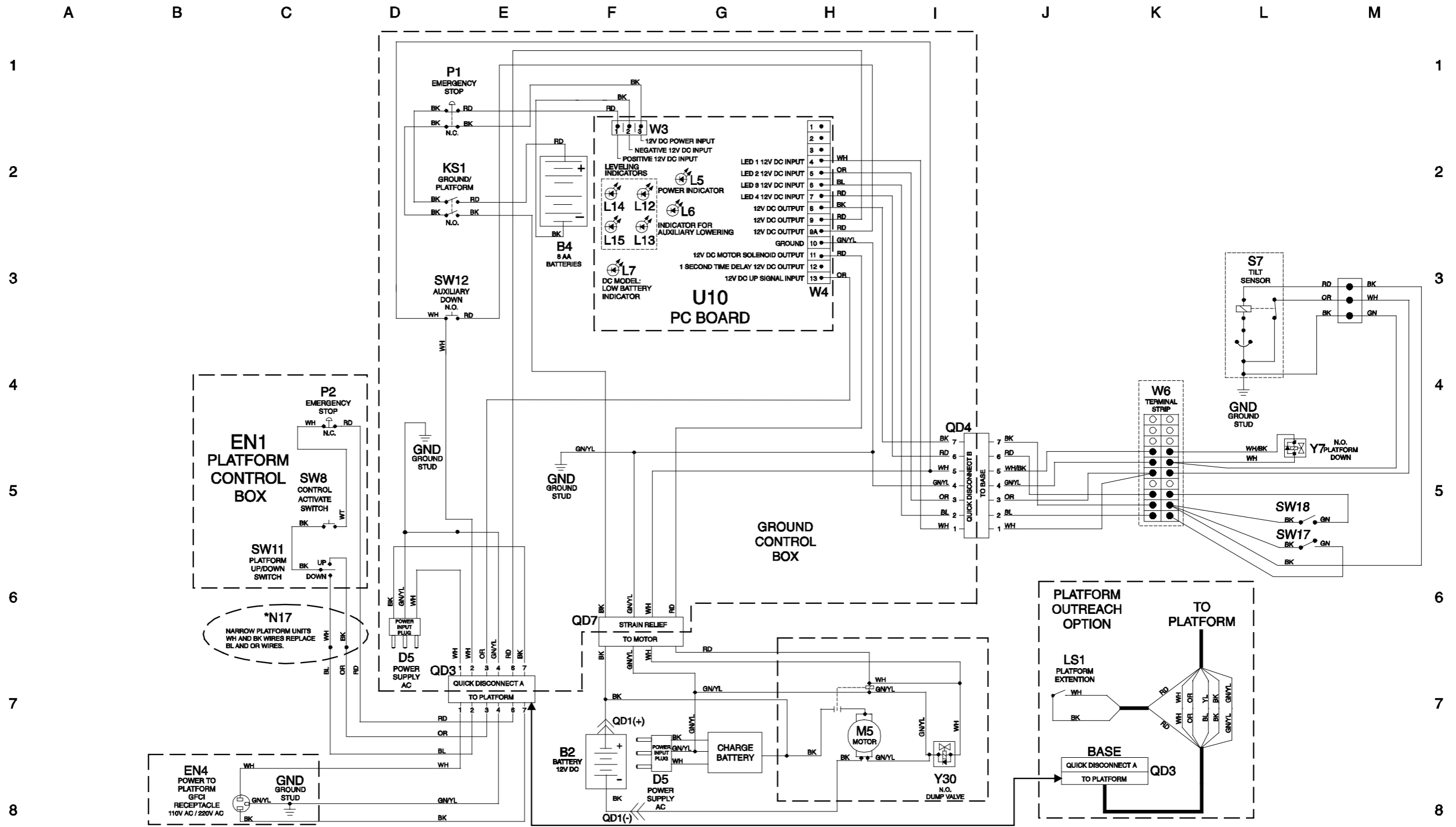

Electrical Schematic - IWP Super Series DC Models
(from SN 4096-288 to 4096-341)

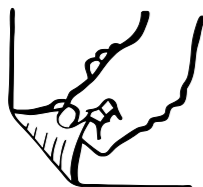

Electrical Schematic - IWP Super Series DC Models
(from SN 4096-342 to IWP07-7065)

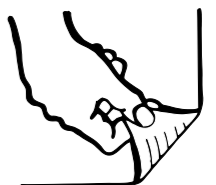

Electrical Schematic - IWP Super Series DC Models
 (from SN 4096-342 to IWP07-7065)

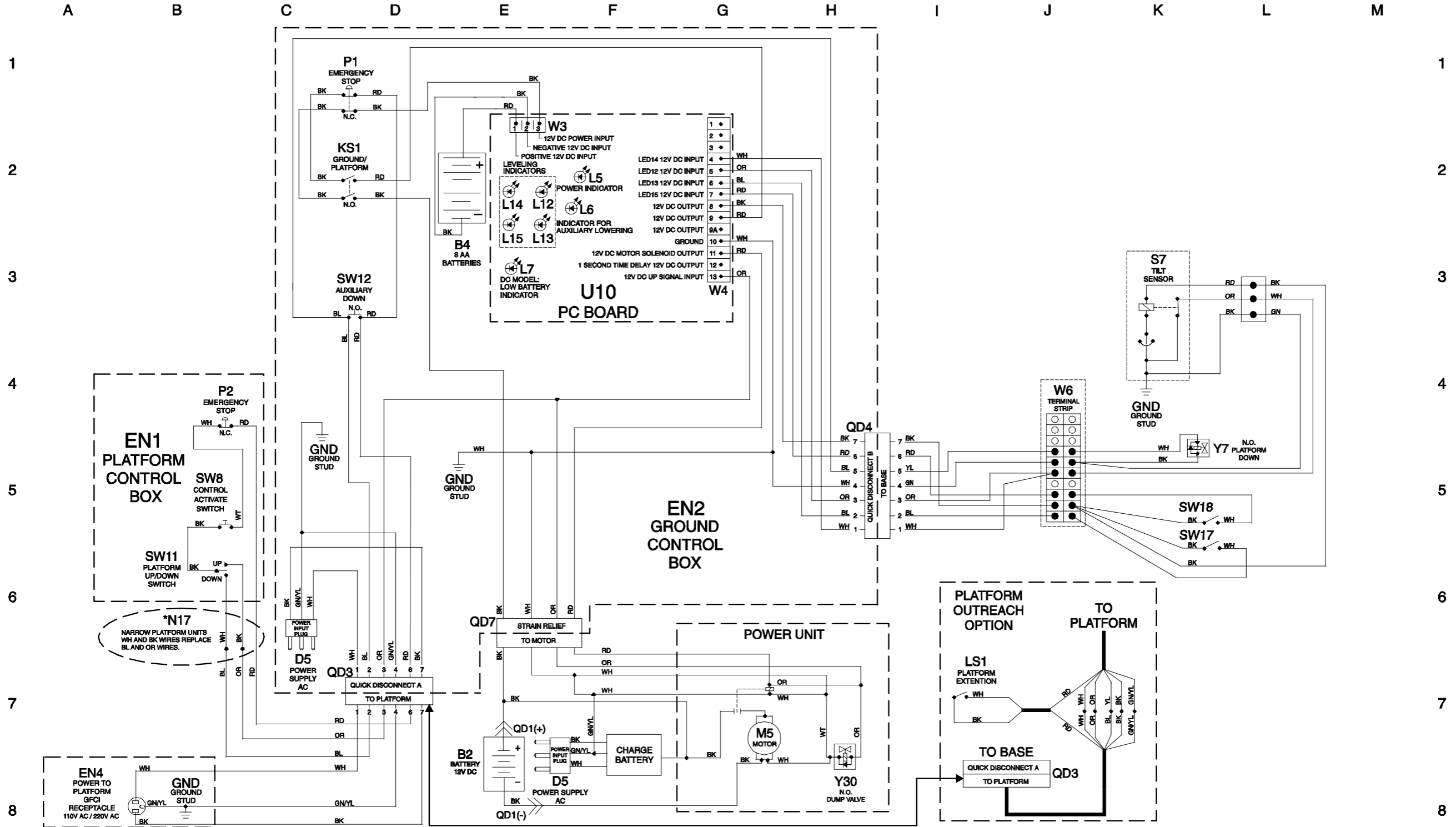

Electrical Schematic - IWP Super Series DC Models
(from SN IWP07-7066 to IWP15-9621)

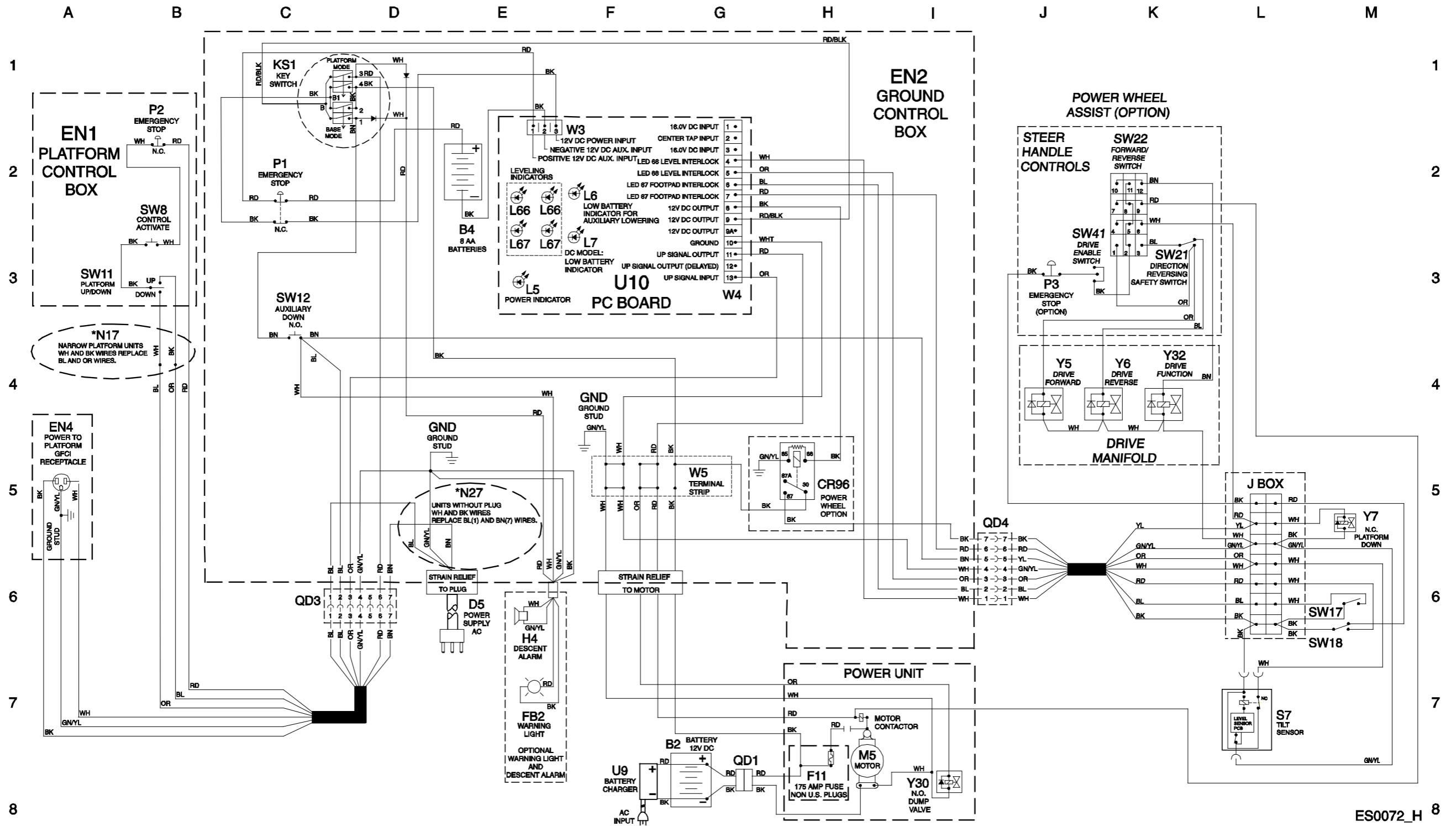

ES0072_H 8



Electrical Schematic - IWP Super Series DC Models
(from SN IWP07-7066 to IWP15-9621)

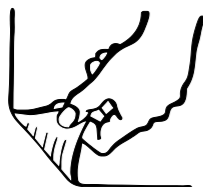

Electrical Schematic - IWP Super Series DC Models
(from SN IWP15-9622)

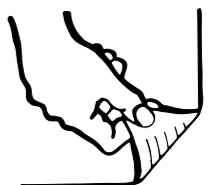

Electrical Schematic - IWP Super Series DC Models
(from SN IWP15-9622)

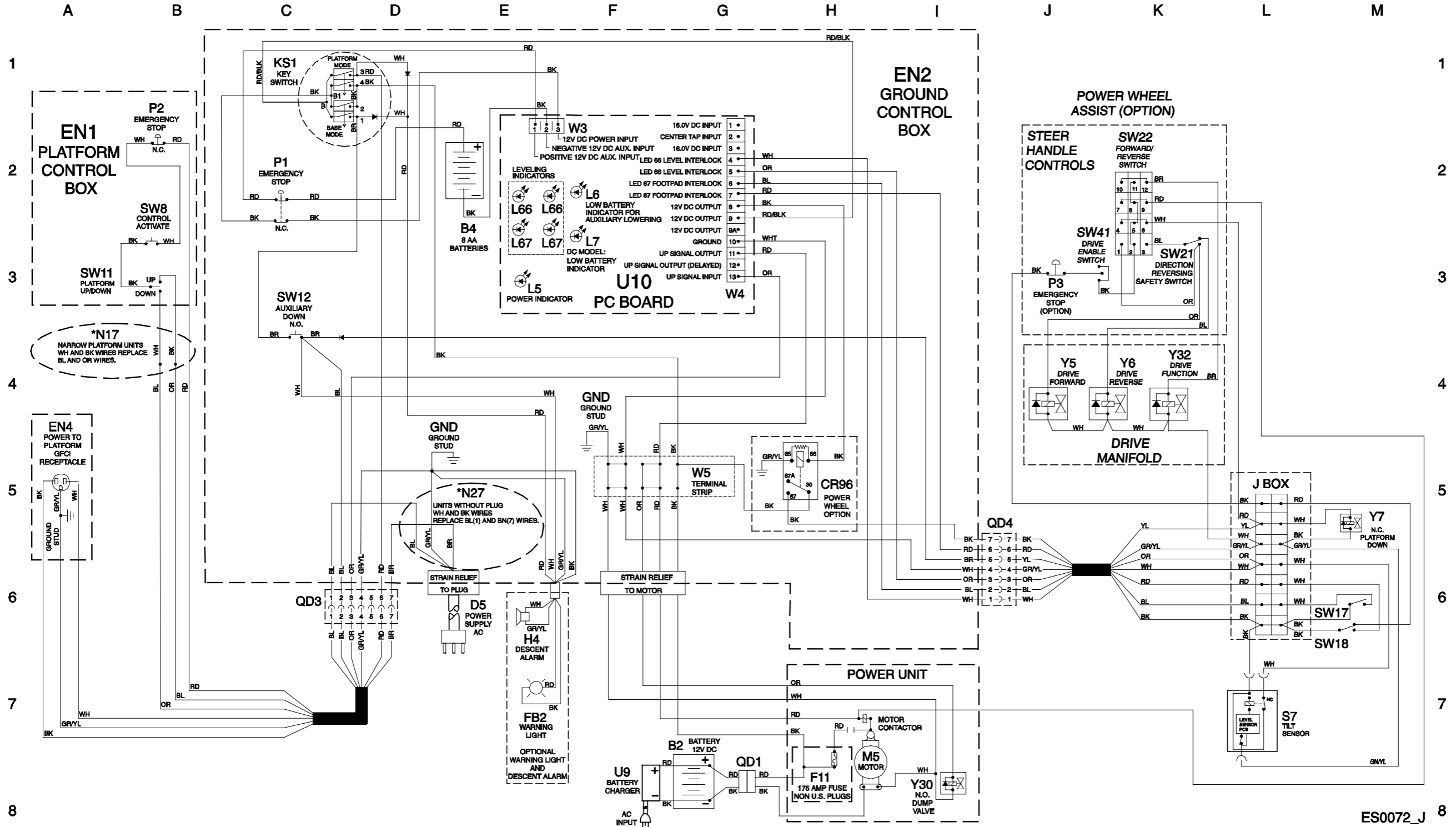

ES0072_J 8



Electrical Schematic - IWP Super Series DC Models with Power Assist

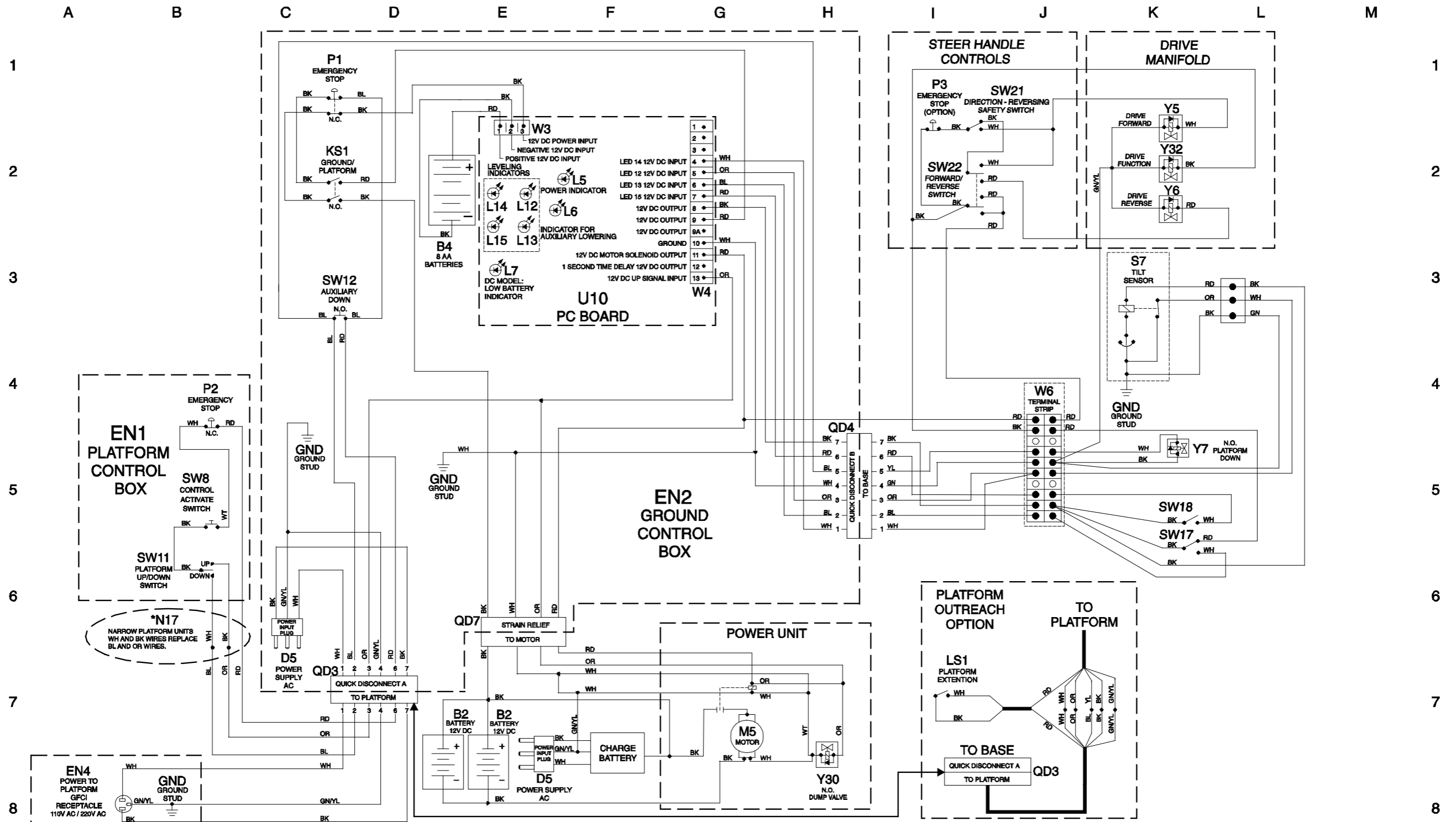

Electrical Schematic - IWP Super Series DC Models with Power Assist

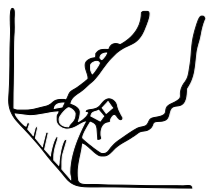

Electrical Schematic - IWP Super Series DC Models with Power Assist
(Directional Valve Coils Powering Function Manifold)

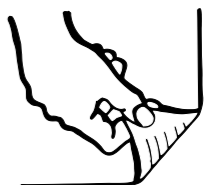

Electrical Schematic - IWP Super Series DC Models with Power Assist
 (Directional Valve Coils Powering Function Manifold)

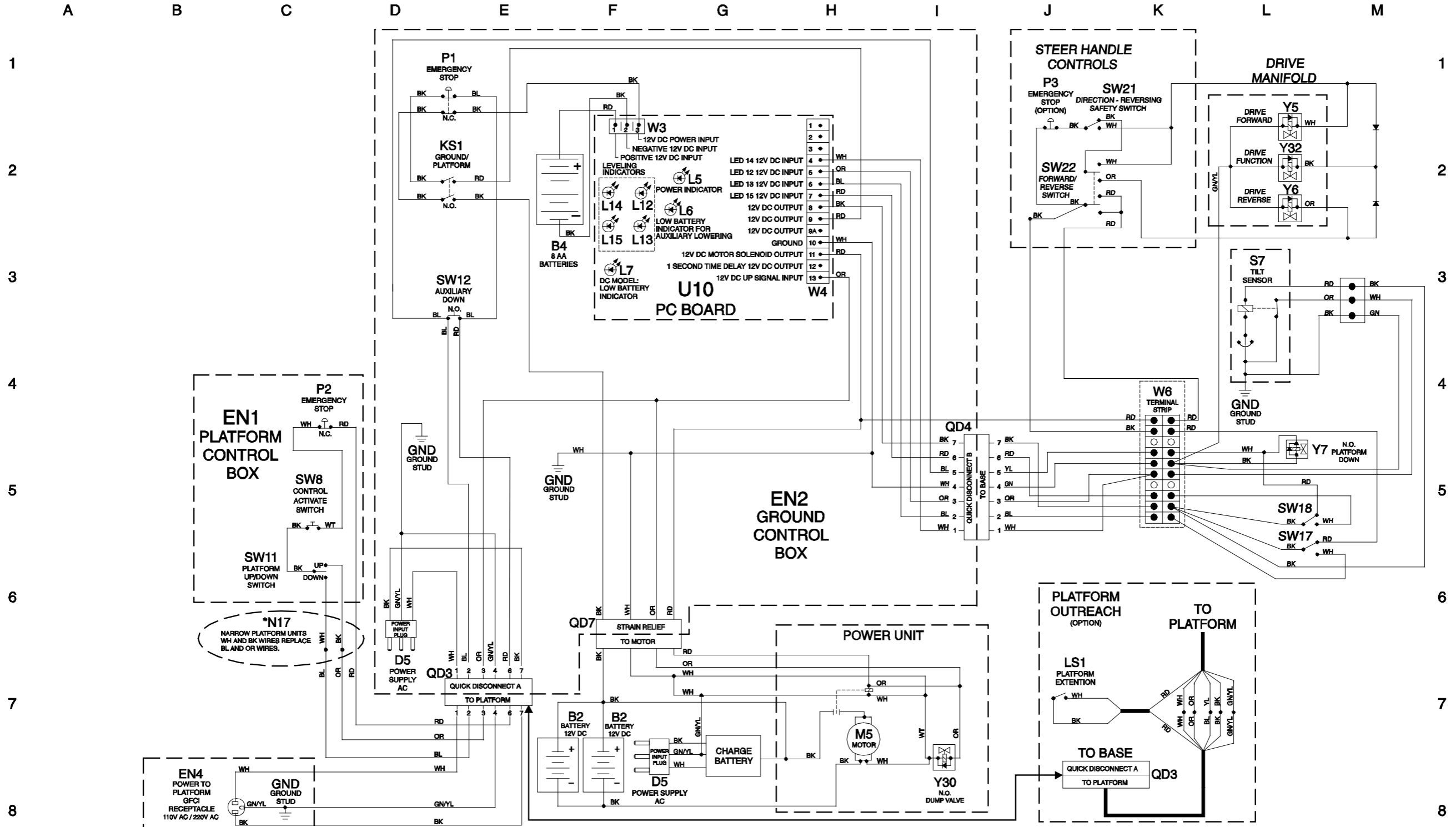

Electrical Schematic - IWP Super Series DC TUV Models

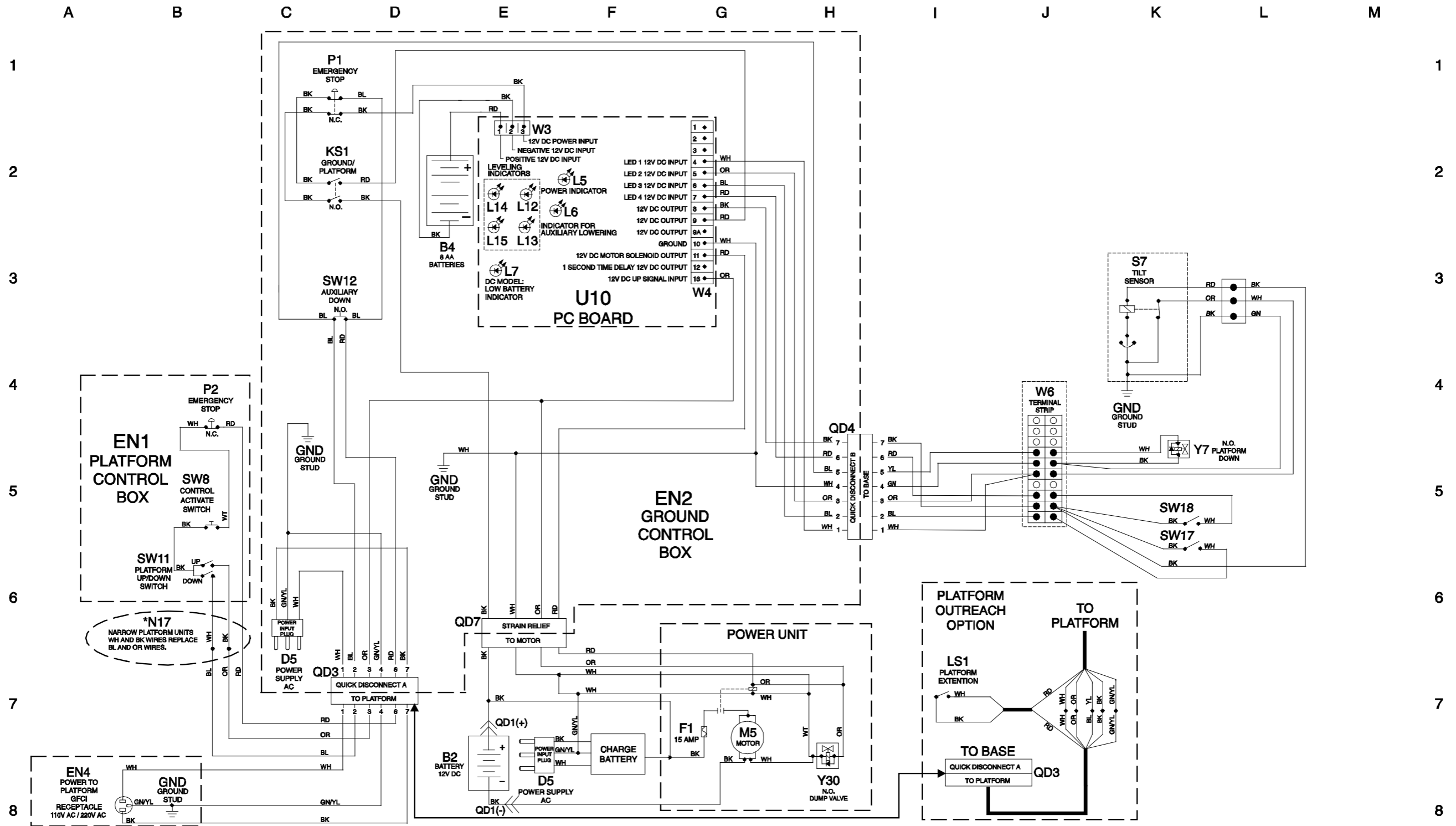

Electrical Schematic - IWP Super Series DC TUV Models

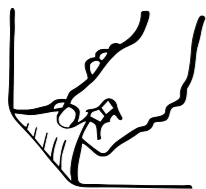

Electrical Schematic - IWP Super Series DC TUV Models with Outreach

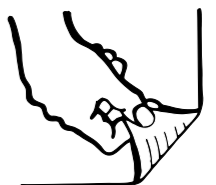

Electrical Schematic - IWP Super Series DC TUV Models with Outreach

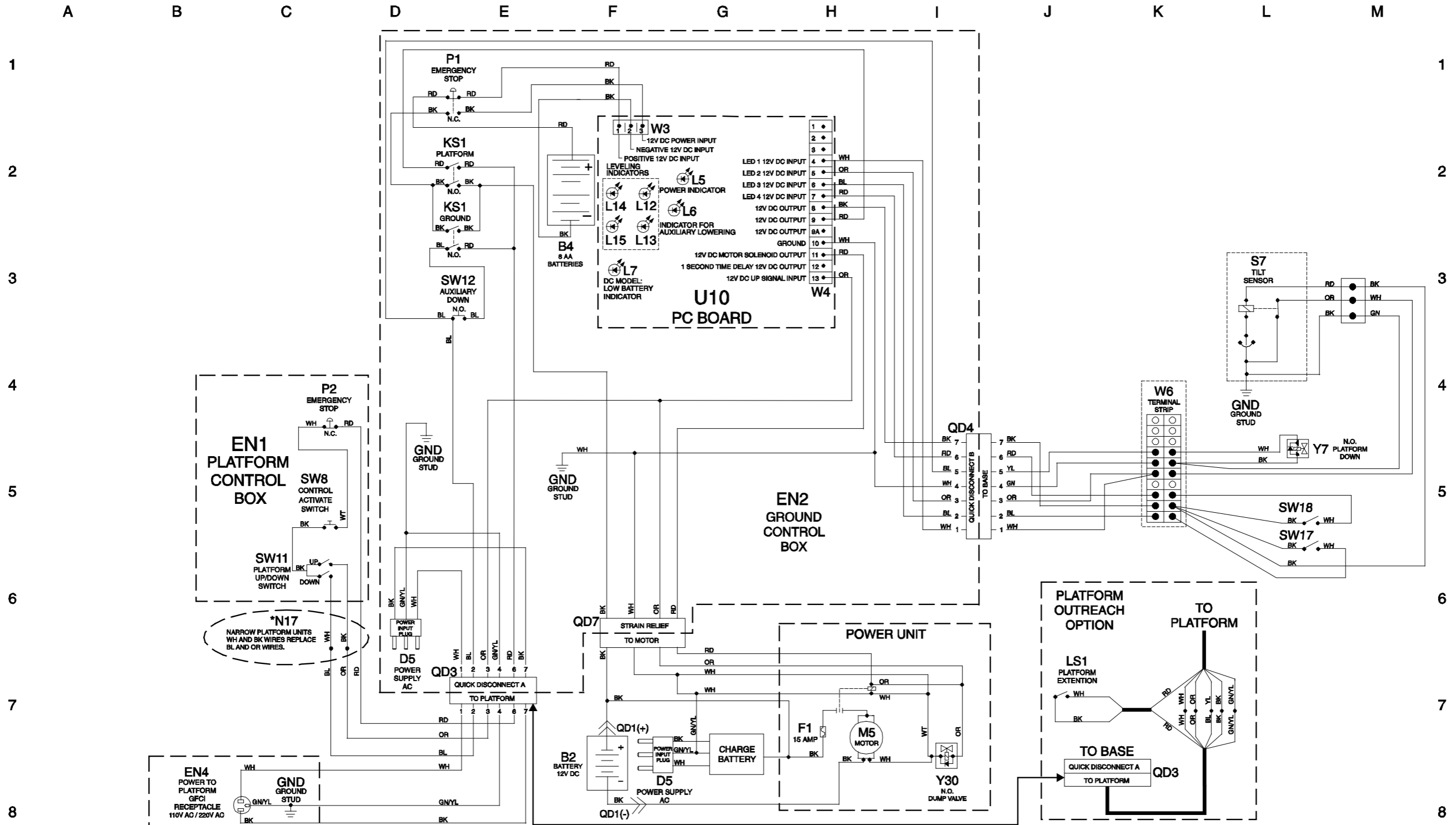

Electrical Schematic - IWP Super Series DC TUV Models with Power Assist

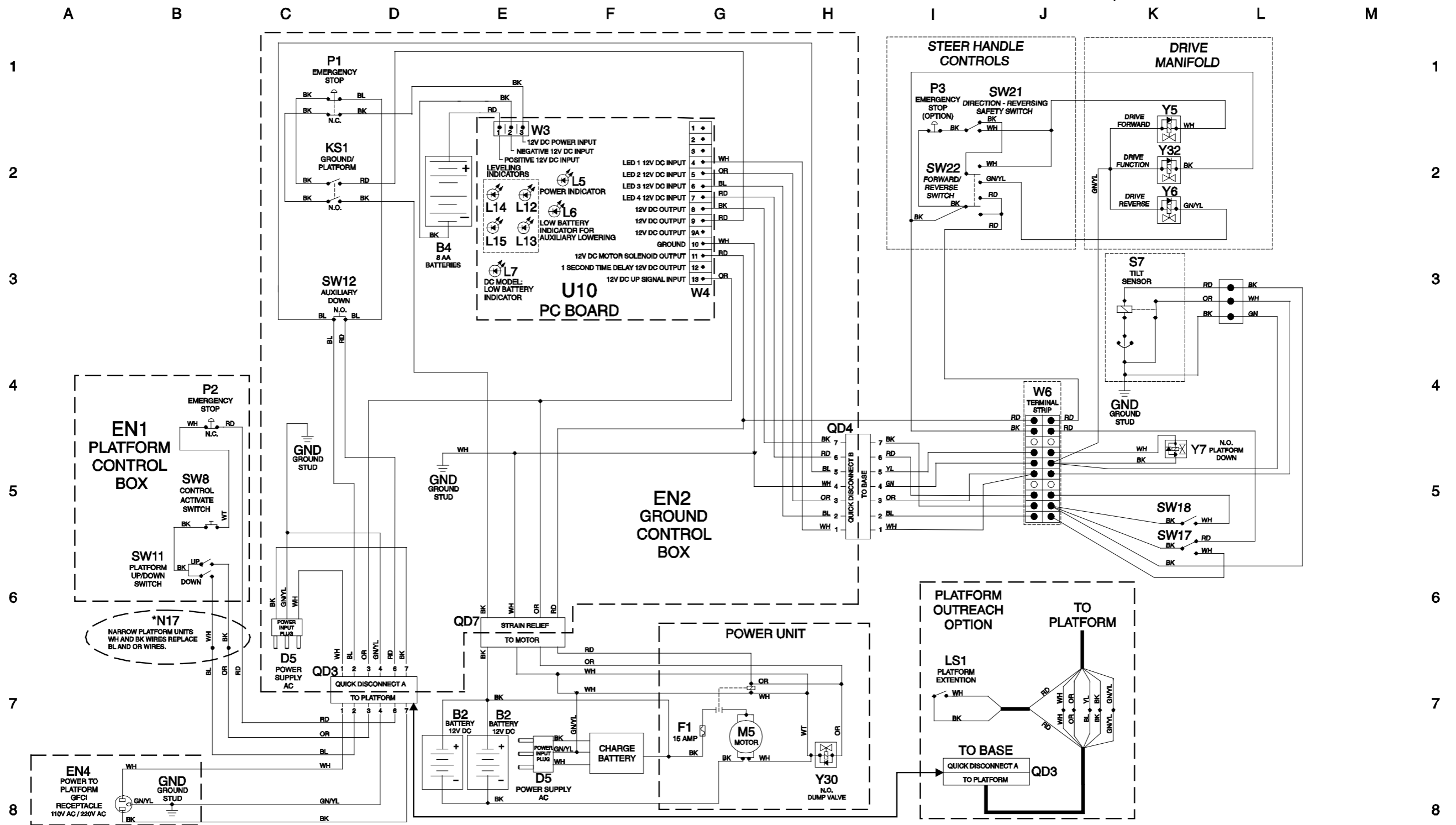

Electrical Schematic - IWP Super Series DC TUV Models with Power Assist

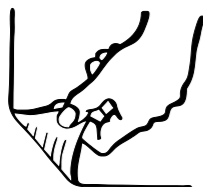

**Electrical Schematic - IWP Super Series DC TUV
Models with Power Assist and Outreach**

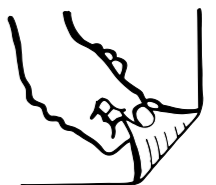

Electrical Schematic - IWP Super Series DC TUV Models with Power Assist and Outreach

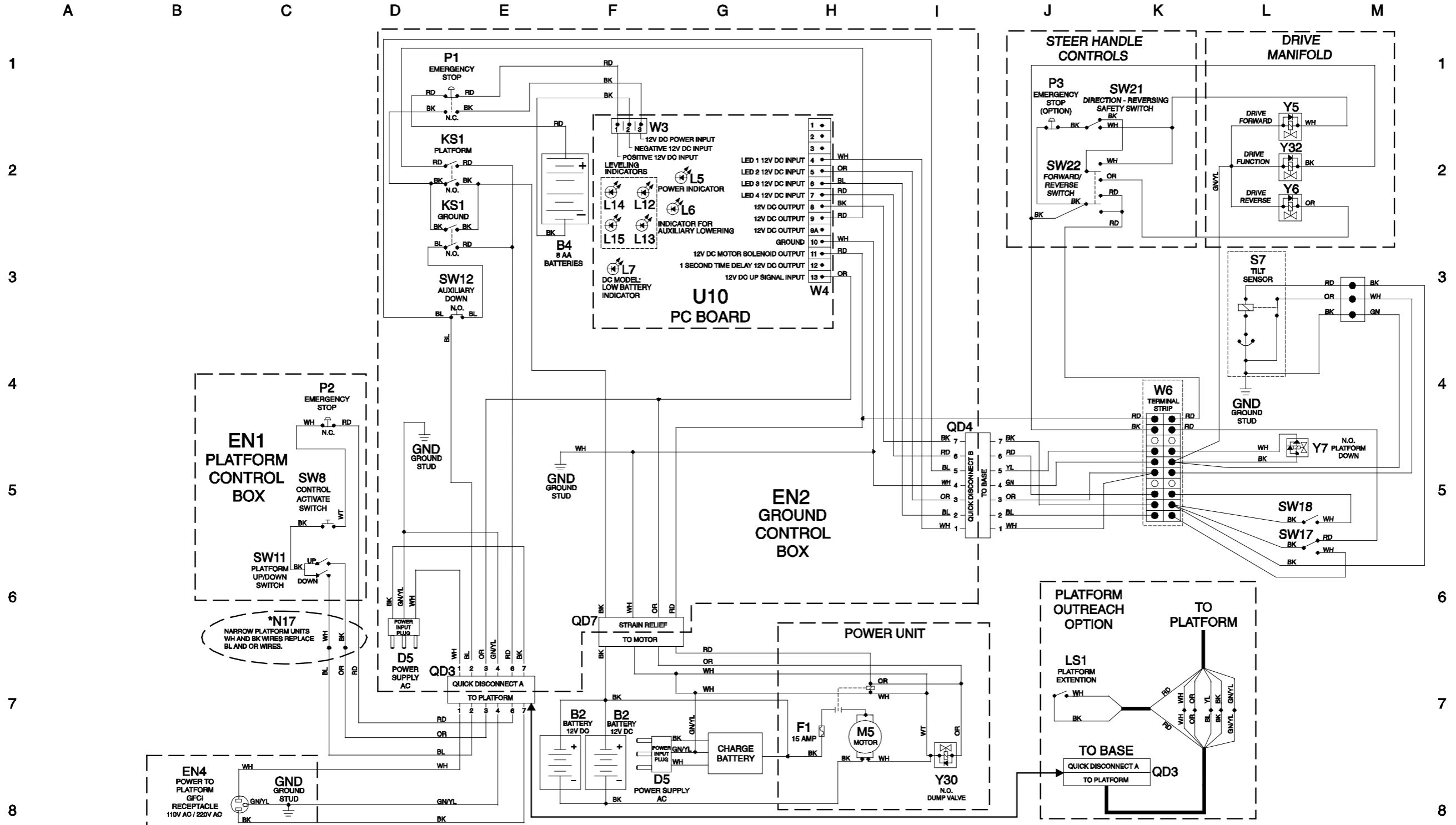

Electrical Schematic - IWP Super Series DC TUV Models with Power Assist
(Directional Valve Coils Powering Function Manifold)

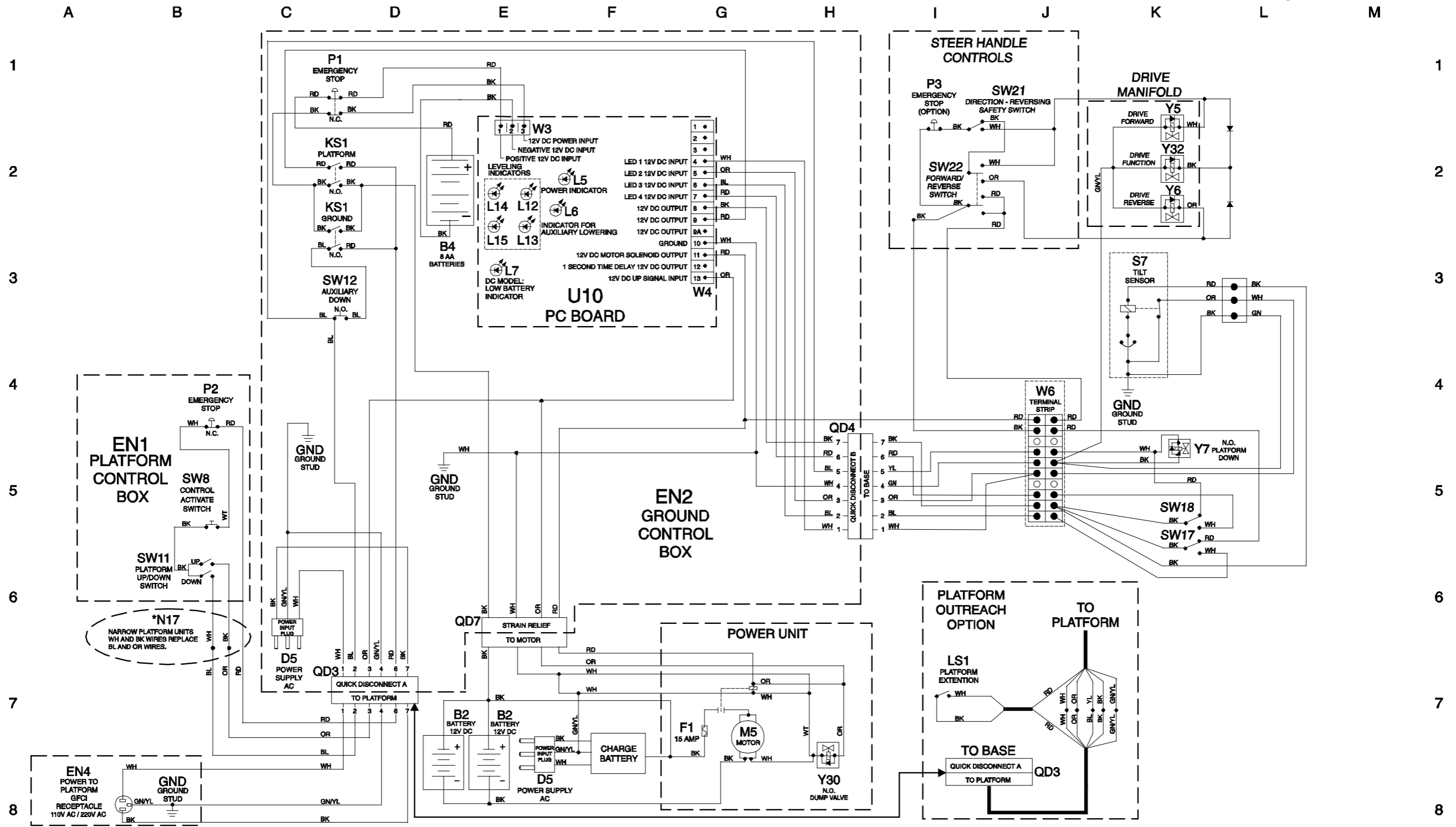

Electrical Schematic - IWP Super Series DC TUV Models with Power Assist
(Directional Valve Coils Powering Function Manifold)

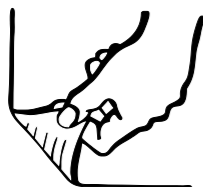

Electrical Schematic - IWP Super Series AC Models
(from SN 4096-105 to 4096-285)

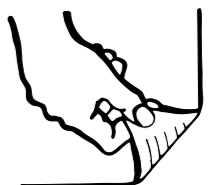

Electrical Schematic - IWP Super Series AC Models
(from SN 4096-105 to 4096-285)

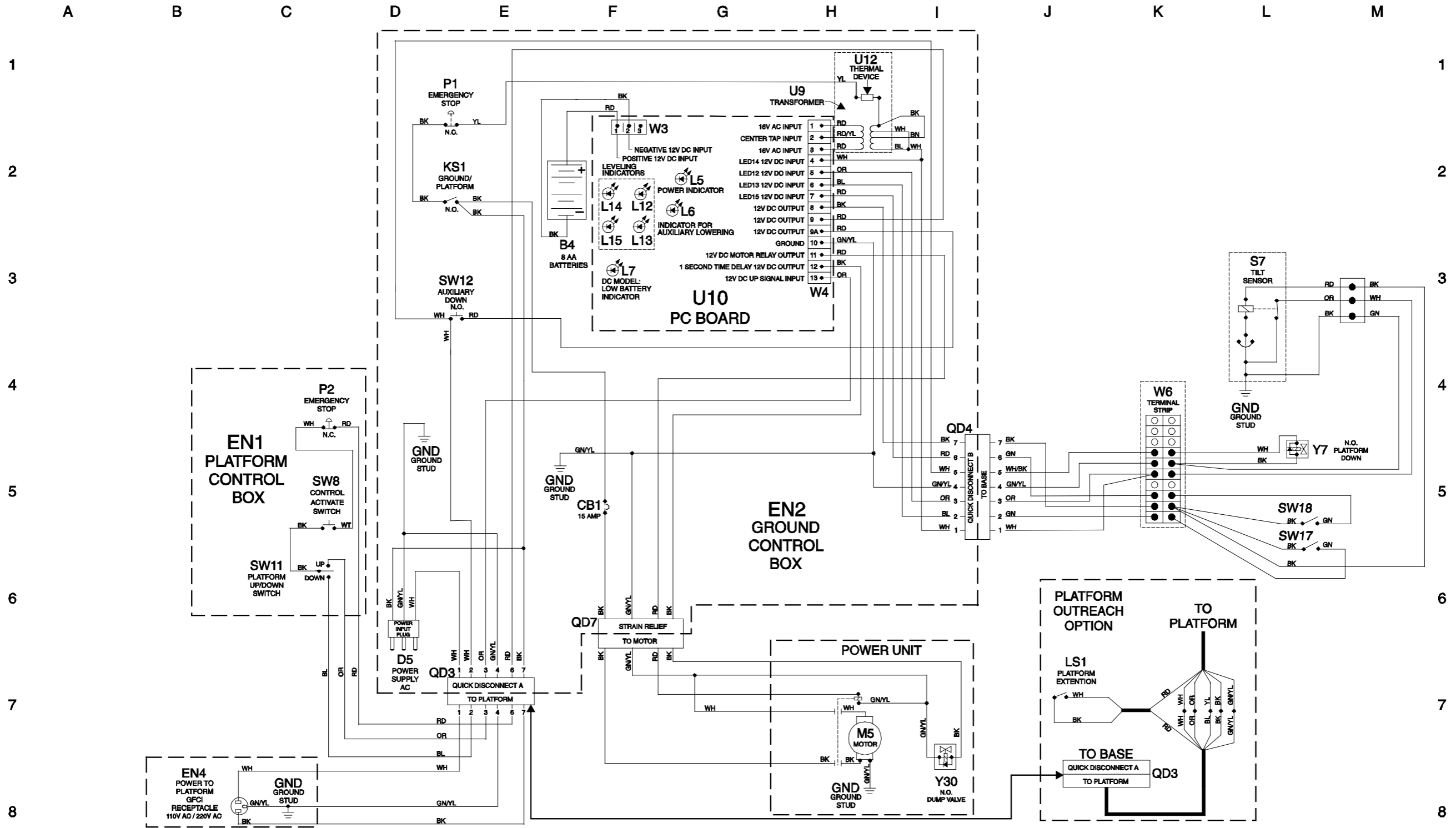

Electrical Schematic - IWP Super Series AC Models
(from SN 4096-286 to 4096-355)

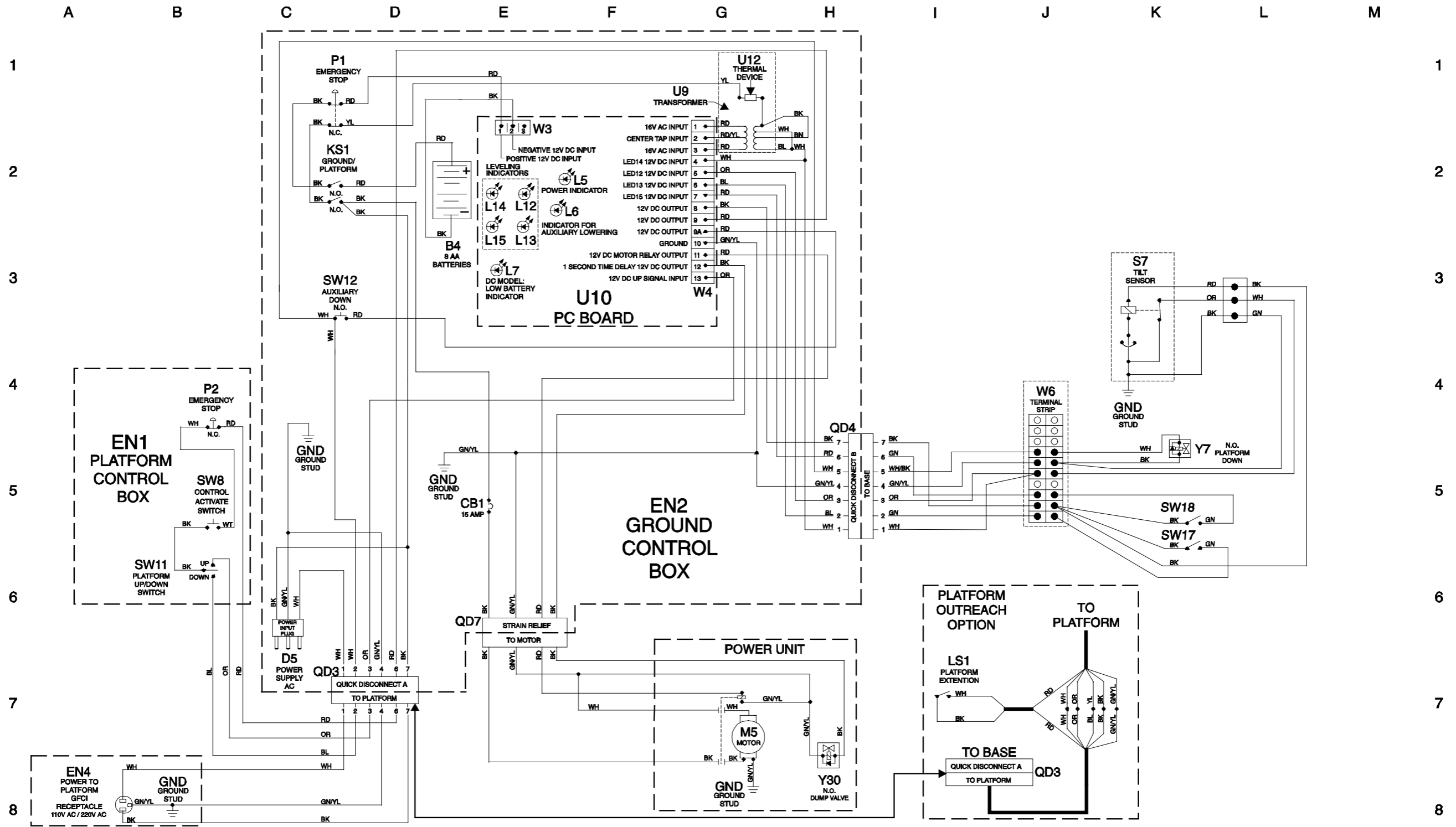

Electrical Schematic - IWP Super Series AC Models
(from SN 4096-286 to 4096-355)

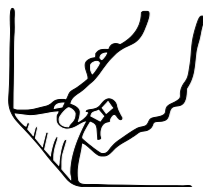

**Electrical Schematic - IWP Super Series AC Models
(from SN 4096-356 to IWP07-7065)**

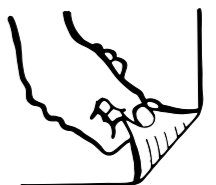

Electrical Schematic - IWP Super Series AC Models
(from SN 4096-356 to IWP07-7065)

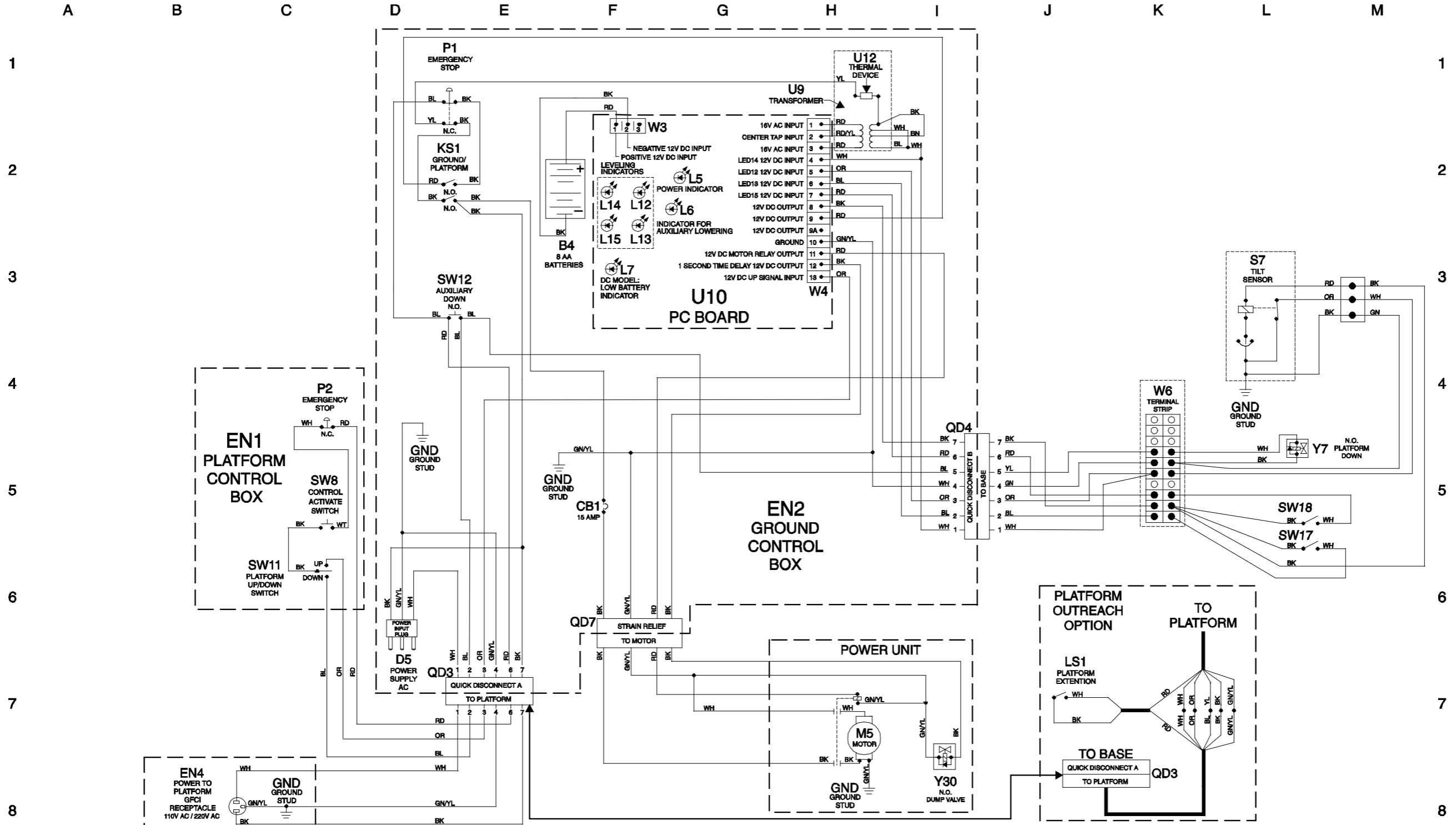

Electrical Schematic - IWP Super Series AC Models
(from SN IWP07-7066 to IWP07-57594)

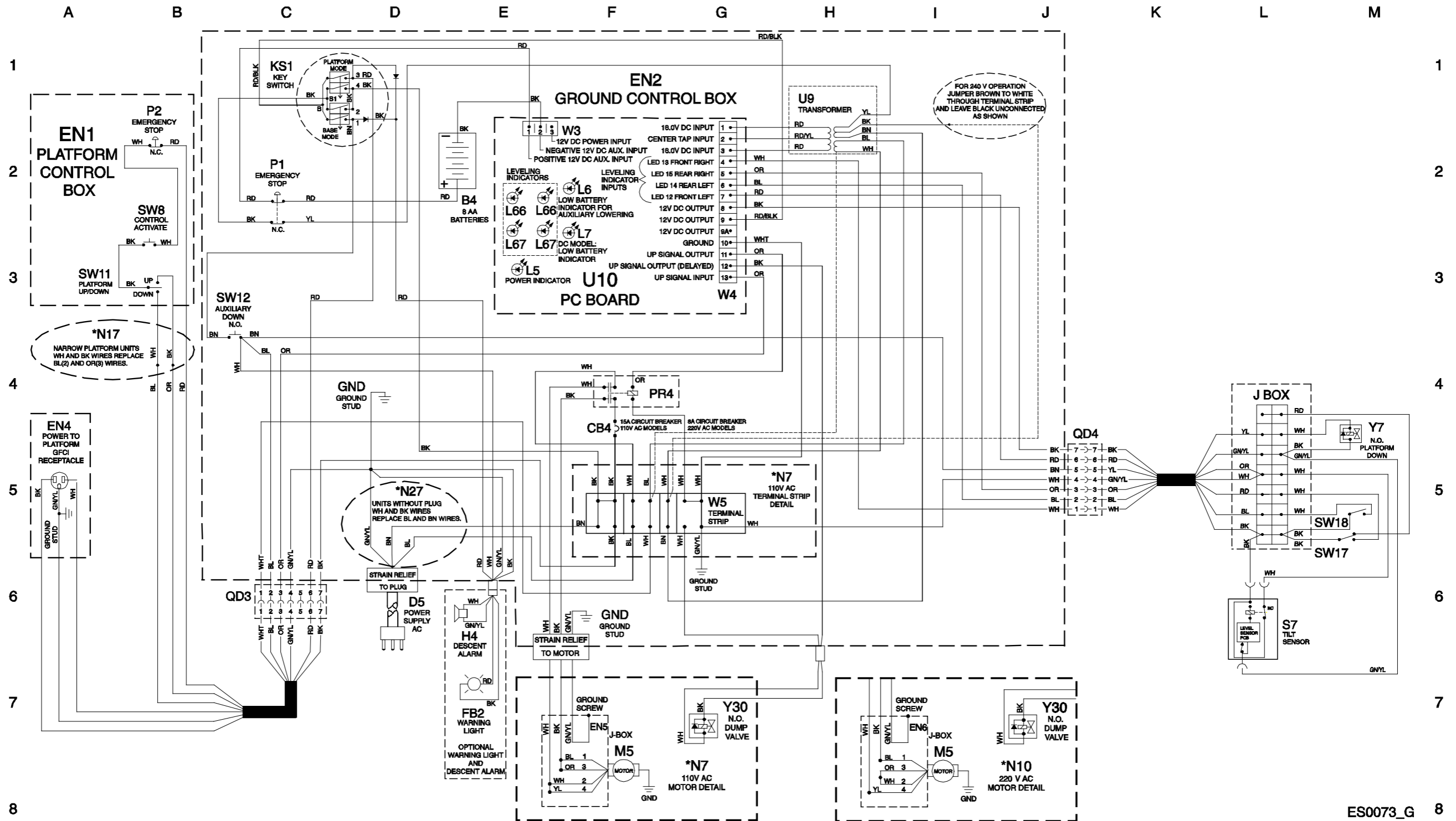

Electrical Schematic - IWP Super Series AC Models
(from SN IWP07-7066 to IWP07-57594)

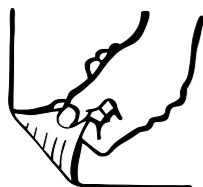

Electrical Schematic - IWP Super Series AC Models
(from SN IWP07-57595)

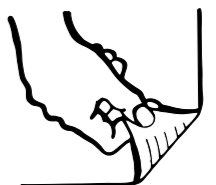

Electrical Schematic - IWP Super Series AC Models
(from SN IWP07-57595)

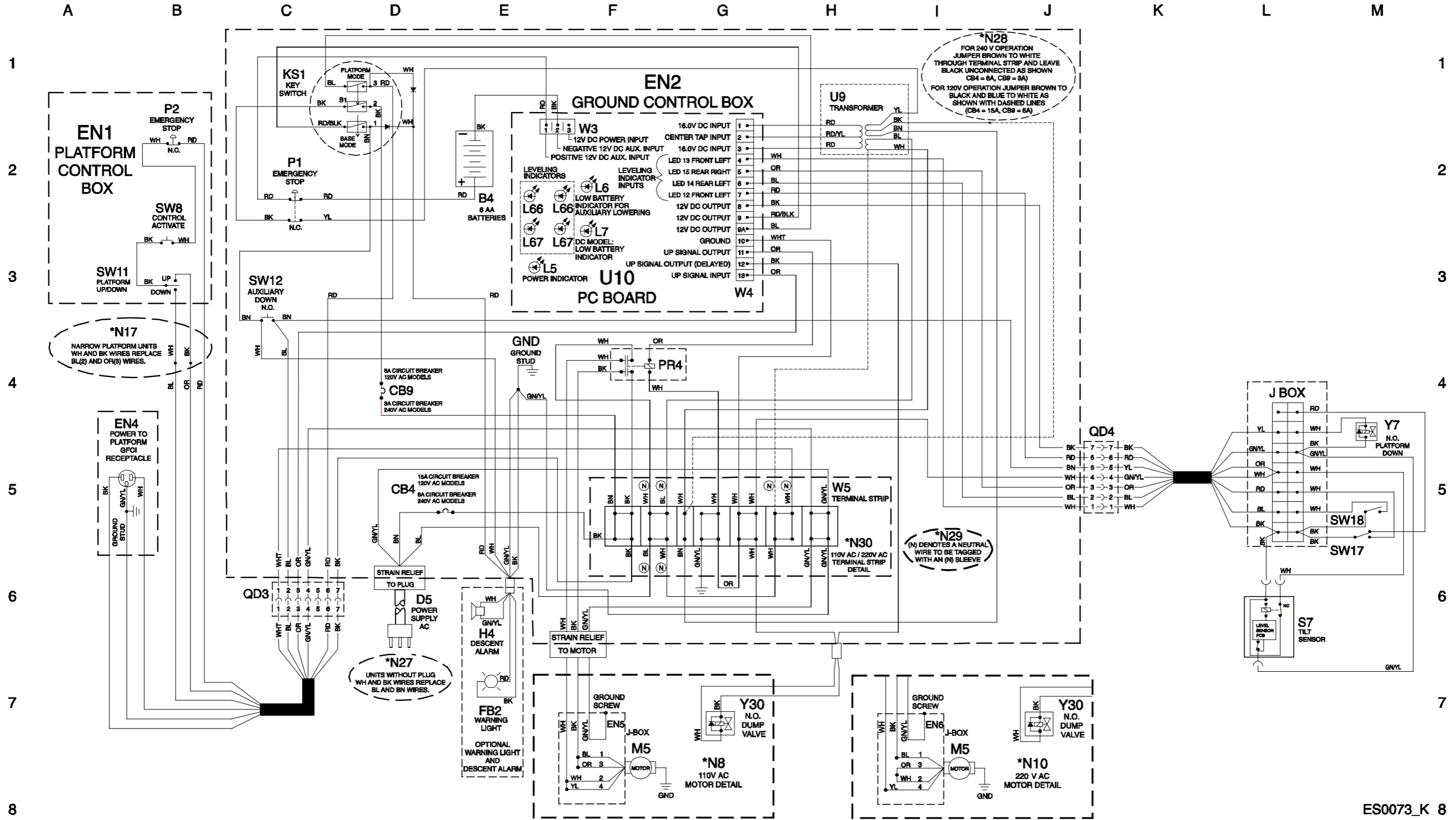

ES0073_K 8



Electrical Schematic - IWP Super Series AC TUV Models
(With Base Mounted Junction Box)

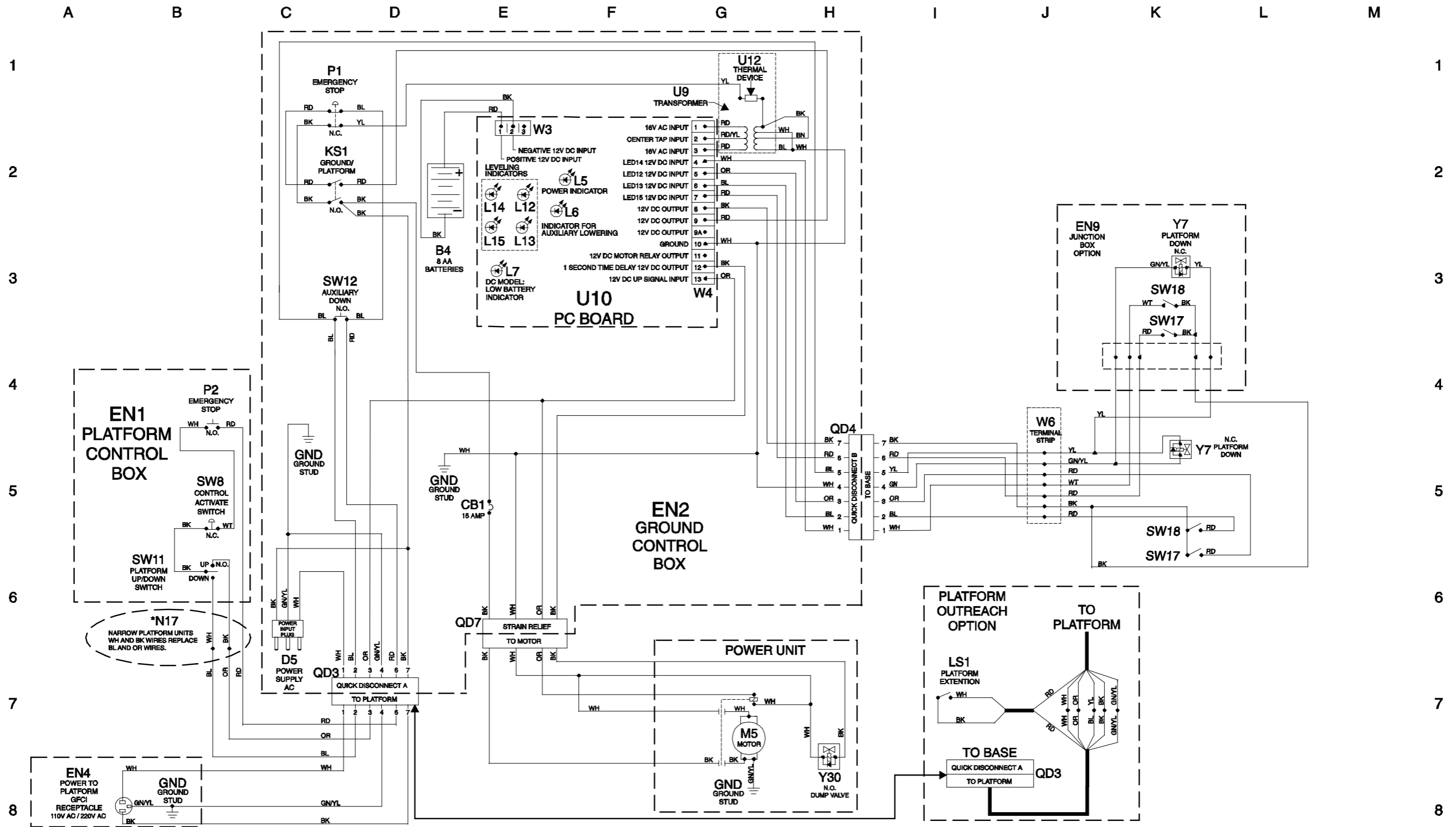

Electrical Schematic - IWP Super Series AC TUV Models **(With Base Mounted Junction Box)**

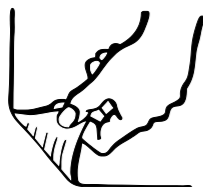

Electrical Schematic - IWP Super Series AC TUV Models
(Without Base Mounted Junction Box)

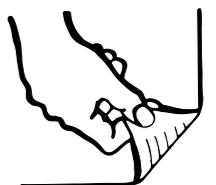

Electrical Schematic - IWP Super Series AC TUV Models
(Without Base Mounted Junction Box)

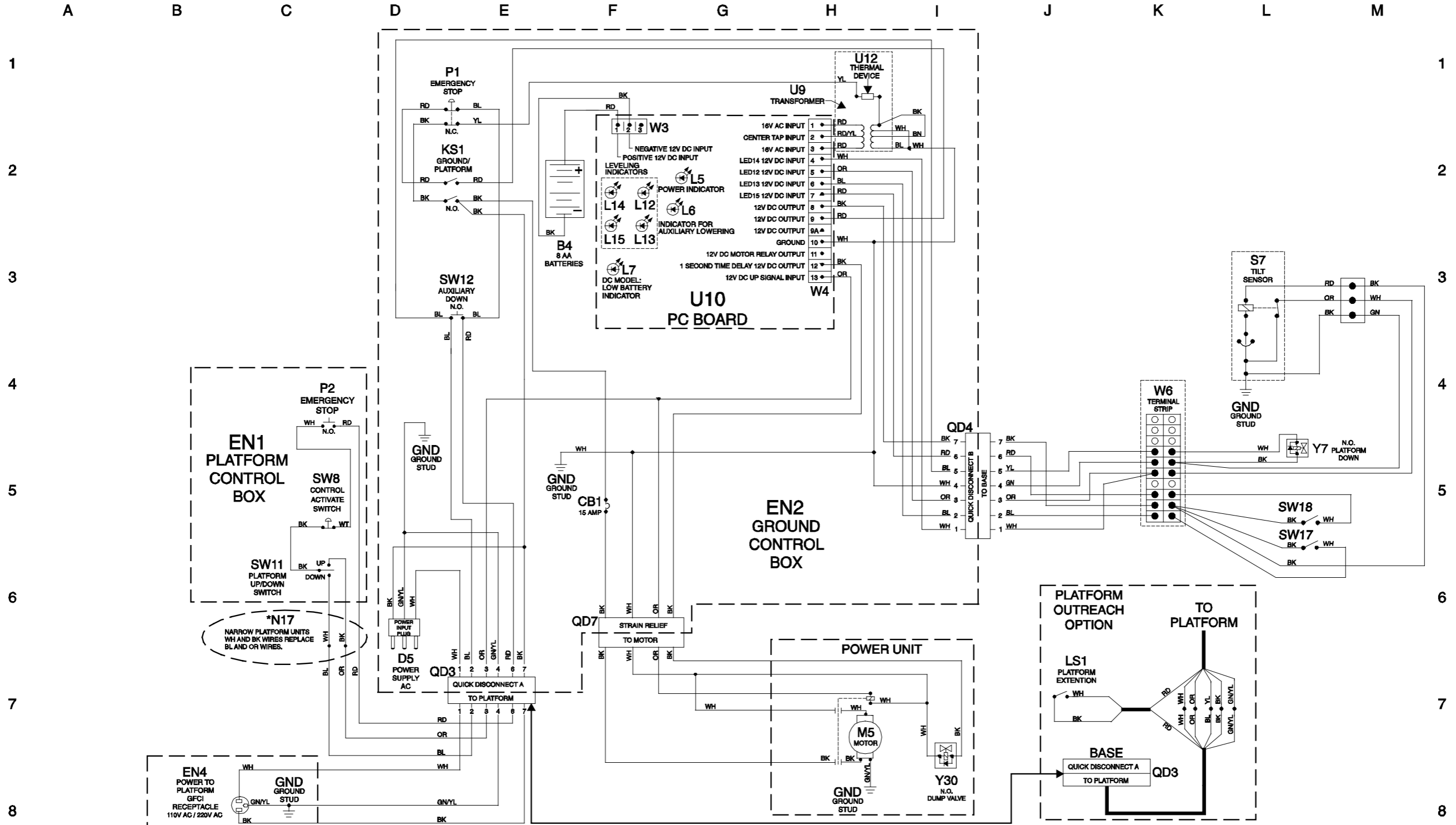

Electrical Schematic - IWP Super Series AC TUV Models with Outreach

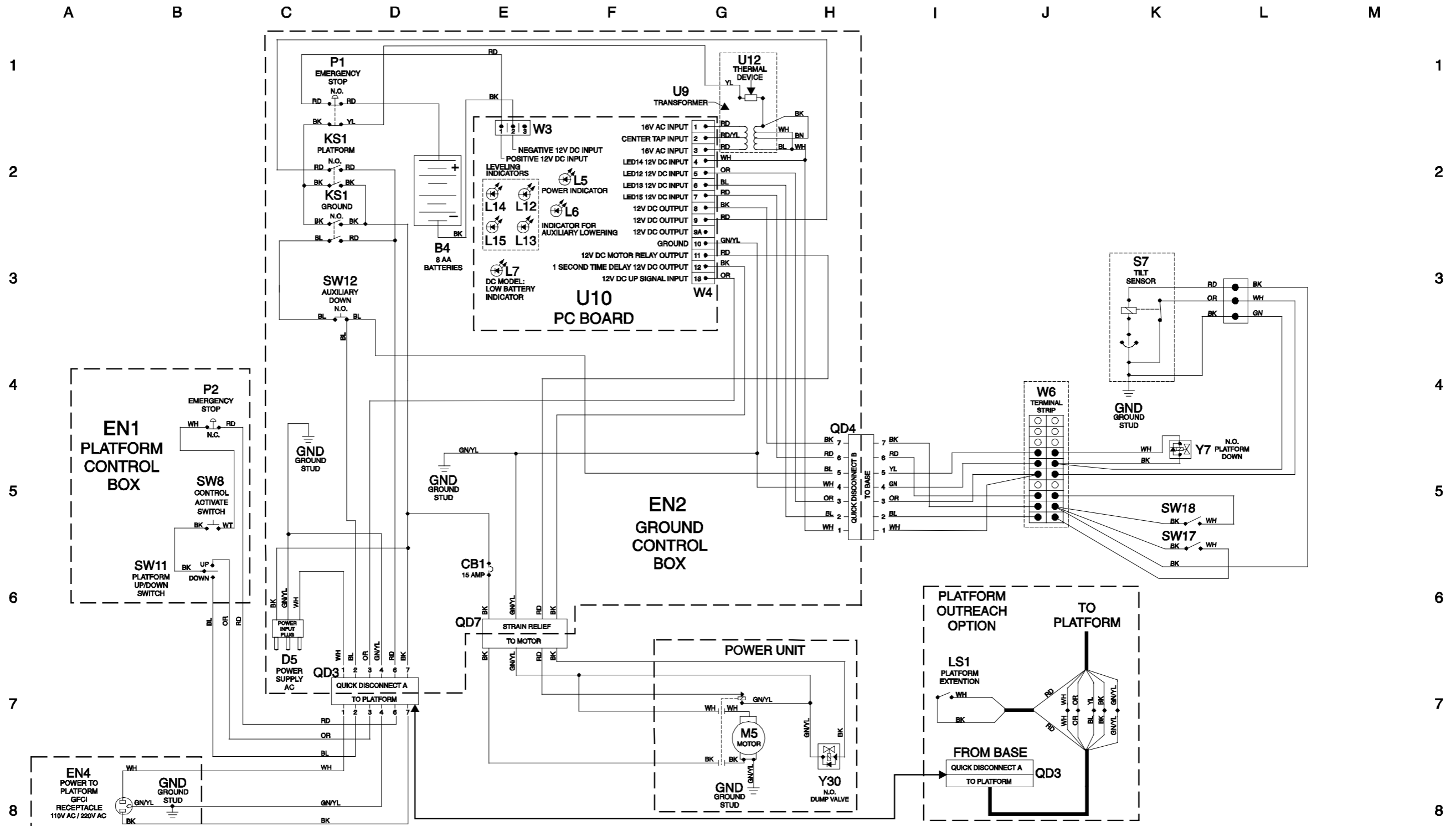

Electrical Schematic - IWP Super Series AC TUV Models with Outreach

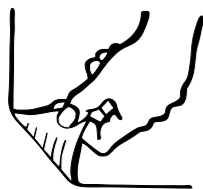

Hydraulic Schematic - AWP Super Series Models

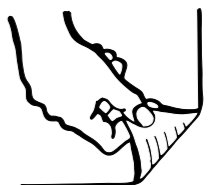

Hydraulic Schematic - AWP Super Series Models

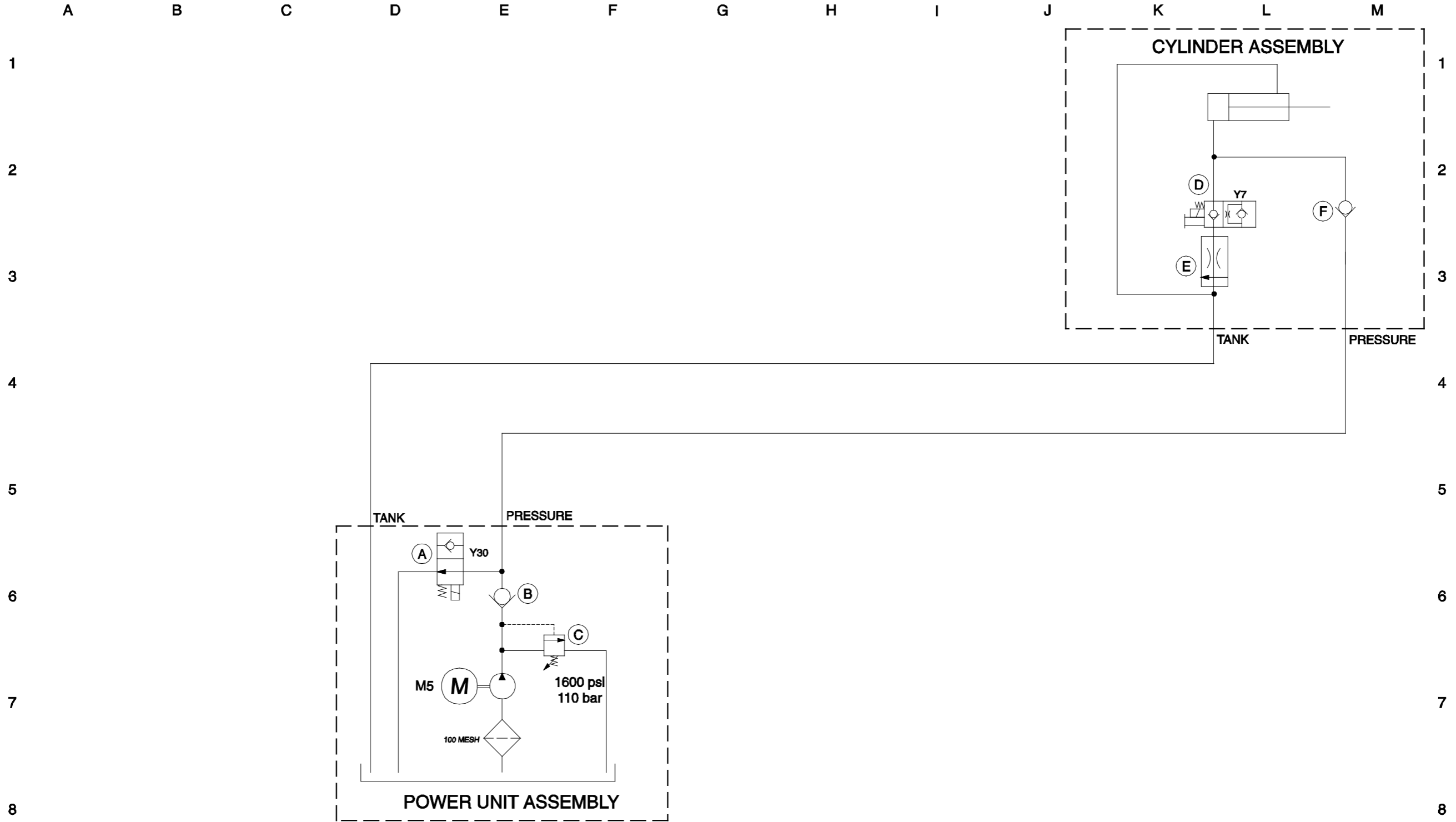

Hydraulic/Pneumatic Schematic - AWP Super Series Models

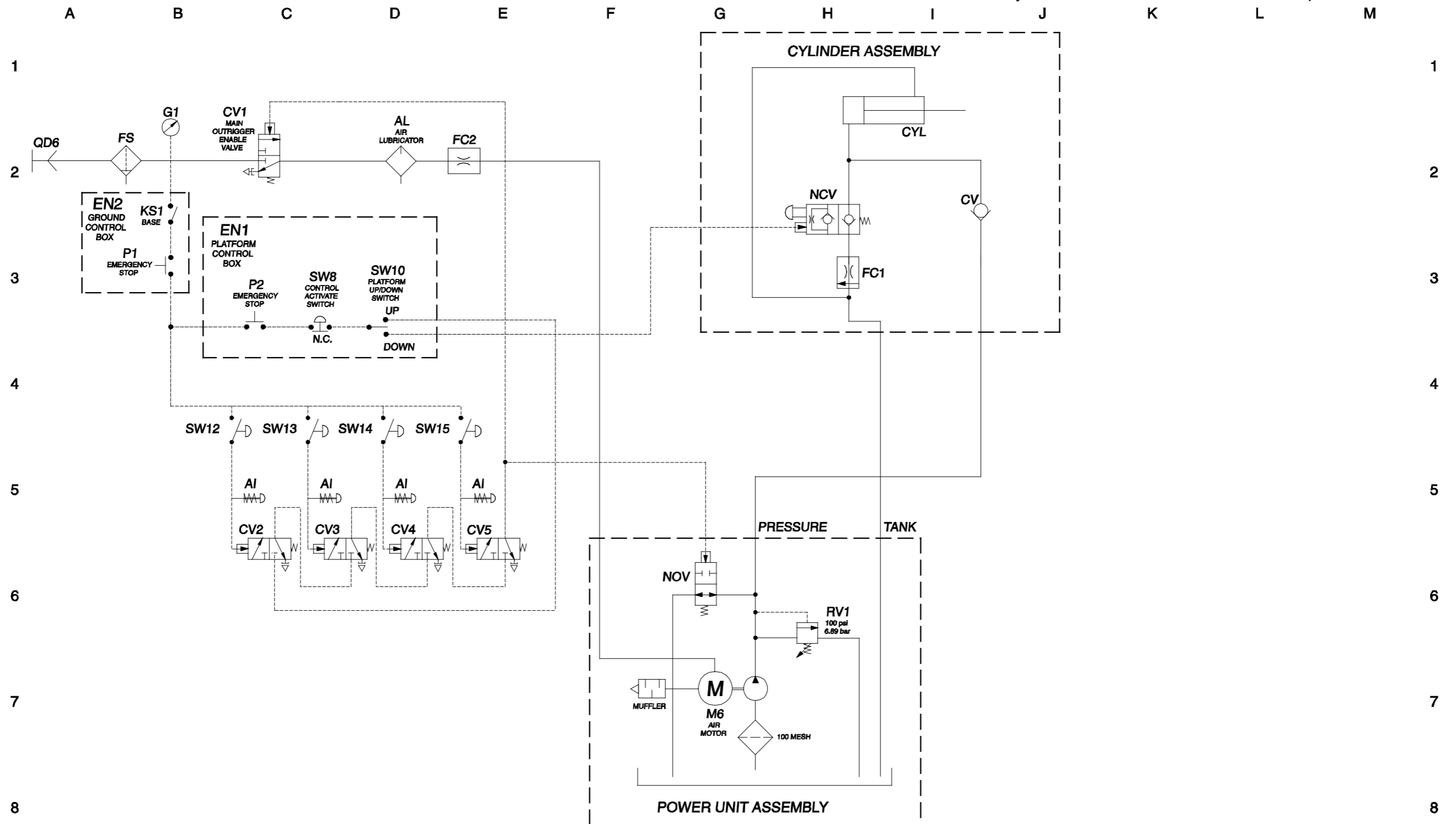

Hydraulic/Pneumatic Schematic - AWP Super Series Models

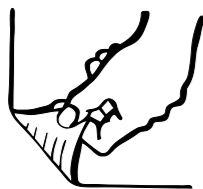

Hydraulic Schematic - IWP Super Series Models without Power Assist

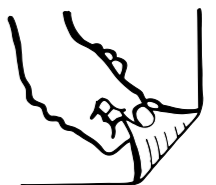

Hydraulic Schematic - IWP Super Series Models without Power Assist

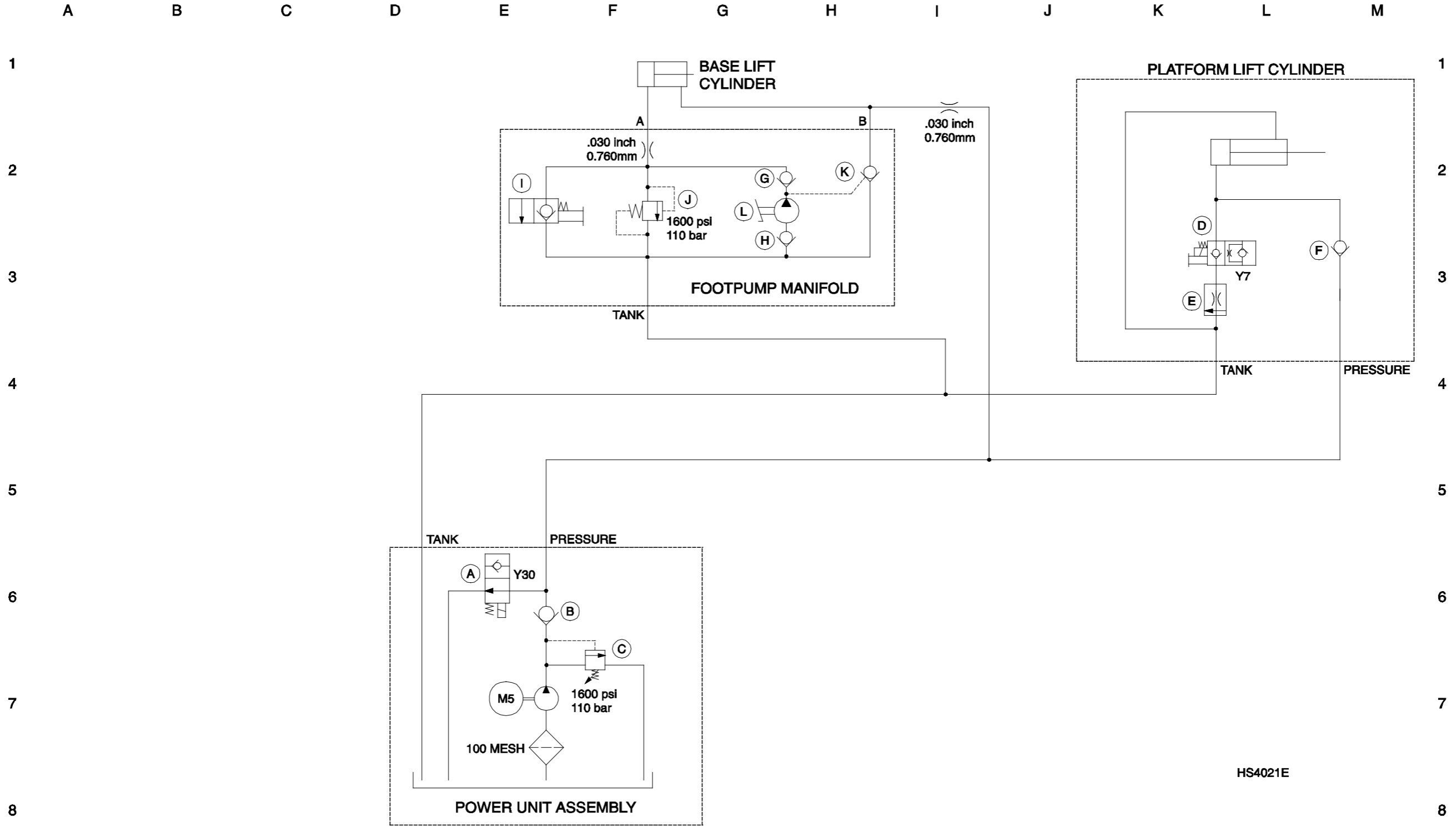

HS4021E

Hydraulic Schematic - IWP Super Series Models with Power Assist

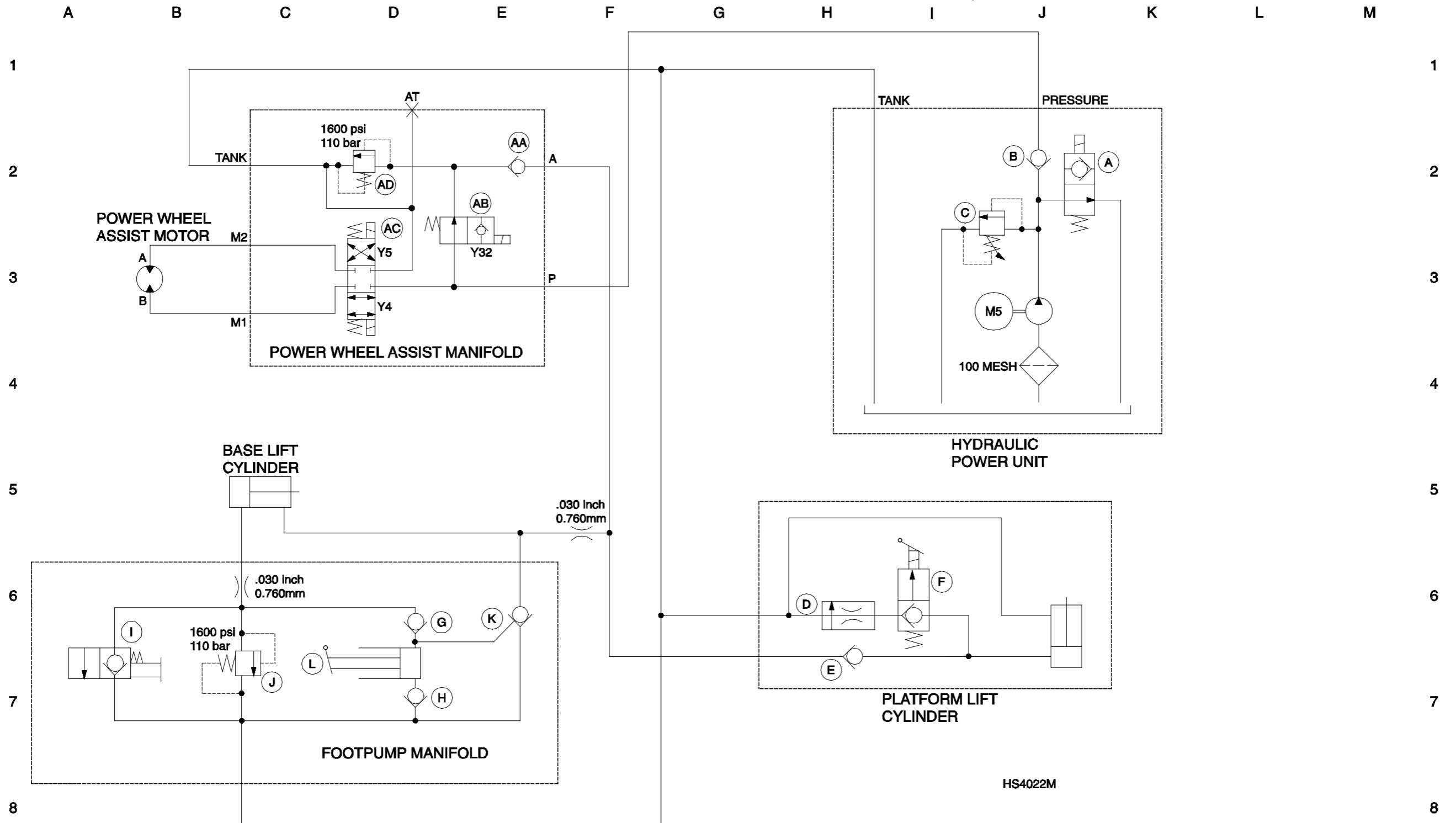

Hydraulic Schematic - IWP Super Series Models with Power Assist

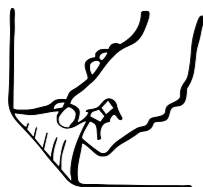

Hydraulic Schematic - IWP Super Series Models with Power Assist and Brake

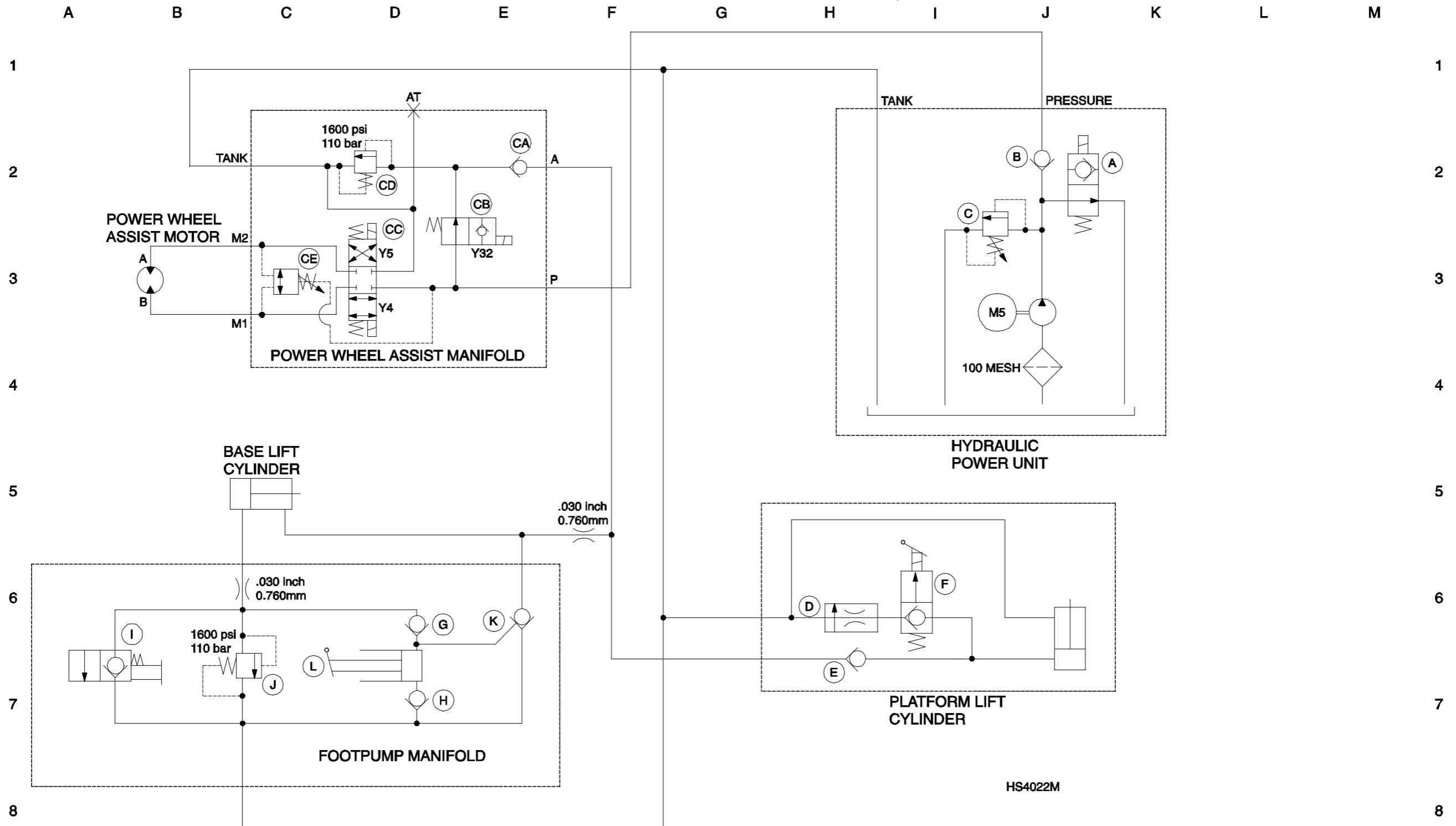

Hydraulic Schematic - IWP Super Series Models with Power Assist and Brake

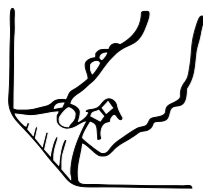

Genie Sweden

Phone 0046 3157 5101
Fax 0046 3157 5104

Genie France

Phone 0033 237 260 986
Fax 0033 237 260 998

Genie Iberica

Phone 0034 900 808 110
Fax 0034 935 725 080

Genie Germany

Phone 0800 180 9017
Phone 0049 4221 491 810
Fax 0049 4221 491 820

Genie U.K.

Phone 0044 1476 584 333
Fax 0044 1476 584 330

Genie Mexico City

Phone +52 55 5666 5242
Fax +52 55 5666 3241

Genie North America

Phone 425.881.1800
Toll Free USA and Canada
800.536.1800
Fax 425.883.3475

Genie Australia Pty Ltd.

Phone +61 7 3375 1660
Fax +61 7 3375 1002

Genie China

Phone +86 21 53853768
Fax +86 21 53852569

Genie Singapore

Phone +65 67533544
Fax +65 67533544

Genie Japan

Phone +81 3 6436 2020
Fax +81 3 5445 1231

Genie Korea

Phone +82 2 558 7267
Fax +82 2 558 3910

Genie Brasil

Phone +55 11 4082 5600
Fax +55 22 4082 5630

Genie Holland

Phone +31 183 581 102
Fax +31 183 581 566

Distributed By: